

A Robust Approach of Embedding Watermark Blocks In Digital Video for Copyright Protection Using Zero Padding Algorithm

P.Chawla and N.Sharma
Department of Electronics and Communication,
Jaypee University of Information Technology,
Solan, Himachal Pradesh.
pallvi.chawla1988@gmail.com

Abstract—Digital copyright protection has become an effective way to prove the ownership and protect the multimedia contents from illegal use and unauthorized users. In order to prove the ownership of a video certain security program is embedded in a video and one of the ways of ensuring the ownership of a video is embedding the watermark in a video. In this paper a new approach of digital video copyright protection with Zero Padding Algorithm (ZPA) is proposed. With the help of this algorithm, it is hard to know the original pattern of watermark. This algorithm splits the watermark into small pieces and minimizes the perceptual degradation of watermarked video because of ZPA. In this paper Digital Wavelet transform (DWT) is used to embed the watermark in the LL sub-band, based on the energy of high frequency sub-band in an adaptive manner. The proposed algorithm has undergone various attacks, such as compression, uniform noise, Gaussian noise, frame repetition and frame averaging attacks. The proposed algorithm, sustain all the above attacks and offers improved performance compared with the other methods from the literature.

Index Terms— Copyright Protection; Digital Video Watermark; DWT; LL Sub-band; ZPA;

I. INTRODUCTION

The future growth of digital copyright protection products basically depends on Real Network and Microsoft Windows Media. Large numbers of these products follow only the protection of copyright of electronic publications, magazines, journals and static images. But still, the necessity of such a platform exists which can apply the copyright protection on digital videos professionally. Nowadays, a large amount of multimedia data has been exchanged over the internet and many internet users are sharing their images, videos and audios. Security provided to protect shared and transferred data over the internet is not enough. There are a variety of approaches for data security such as steganography, fingerprinting, copyright protection [1]-[5], and so on. The main focus of this paper is on the Copyright Protection technique of data security in Digital Videos. For this, Digital Watermark or digital pattern (text, image, audio or Video) is inserted inside Digital Video Frames. Some important aspects of watermark systems include Robustness (quality of the watermark should not be degraded due to any attack, whether the attack is intentional or unintentional), Transparency (the data embedded inside the video frames that should not be visible), Capacity, and Security (to control the illegal use of data). An attacker may crack, damage or detect watermark, but in this algorithm, it

is very difficult to detect the original pattern of inserted watermark [6]-[9]. This algorithm improves the robustness and security of inserted digital pattern or watermark and transparency of watermarked media. Figure 1 shows the block diagram of video watermarking. To extract the watermark, watermark detection algorithm is applied on watermarked video.

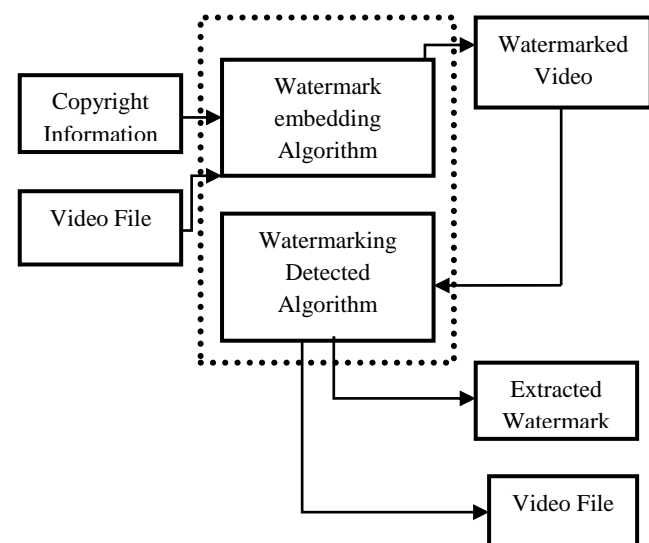

Figure 1: Video Watermarking

In this paper, a ZERO PADDING technique is applied to ensure the authorized owner of the video. Attacks are performed to ensure that video can bare it in order to maintain its originality and authorization. Attacks can be Spatial attack, compression attacks and temporal attacks, etc. In this paper, digital video copyright protection using DWT is proposed. Extraction of I-frame, watermark preprocessing [7]-[15], watermark embedding [16]-[18] and extraction [19]-[24] are implemented in this paper. This platform embeds a watermark on video for copyright protection to satisfy the client's requirements and then, embedded watermark is extracted from the original source video to authenticate the copyright. Extracted watermark is compared with original watermark to verify whether the product is authorized or not.

The rest of the paper is organized as follows: In Section II, the proposed scheme is illustrated which explains the embedding and extraction of the watermark from video sequence. Section III shows some experimental results and evaluates the performance of the proposed technique. At the

end, conclusions are drawn in Section IV.

II. PROPOSED APPROACH

In the proposed method, a gray level image (256 x 256) is used as a watermark signal shown in figure 2(a). For embedding the watermark, 'Foreman' and 'Car_race' video sequences are taken. After applying scene changed algorithm on these video sequences, 77 and 97 scenes changed frames are obtained respectively. Before embedding, watermark and input video are preprocessed. This algorithm first splits the watermark to a particular size.

$$(4^n \leq m; n > 0)$$

Where m is the total no. of the scene changed frames of video and 4^n is the total number of split watermark in which n is an integer. In this case, the watermark will be divided into 4^n small images that are shown in Figure 2(b). Figure 2 shows an original watermark juit.jpg (256 x 256). Now apply the proposed algorithm on juit.jpg and obtain small pieces of watermark (32 x 32) in fig 2(c). In Figure 3, a scene changed detection algorithm is applied to input video sequence and get the non-overlapping GOP [10]. Select the I-frame with the help of the frame selection scheme. After getting the I-frames, apply 2-level DWT and obtain the higher (HH HL) and lower frequency band (LL LH) [11], [12]. After performing 2-DWT on each I-frame (Identical Frame) of video, we get LL-2 (2nd Level low frequency band), which is named as (Lf_2). Then 2-DWT technique is applied to each splitted watermark block and LL-2 is obtained, which is named as (Wm_2) and multiplied by a scaling factor β . After getting scaled (Wm_2) and (Lf_2), add them with the help of ZPA then apply IDWT (Inverse discrete wavelet transform) on a video frame (Lf_2) and the result stores in WmI_i .

$$WmI_i = (Lf_2) + \beta \times (Wm_2) \quad (1)$$

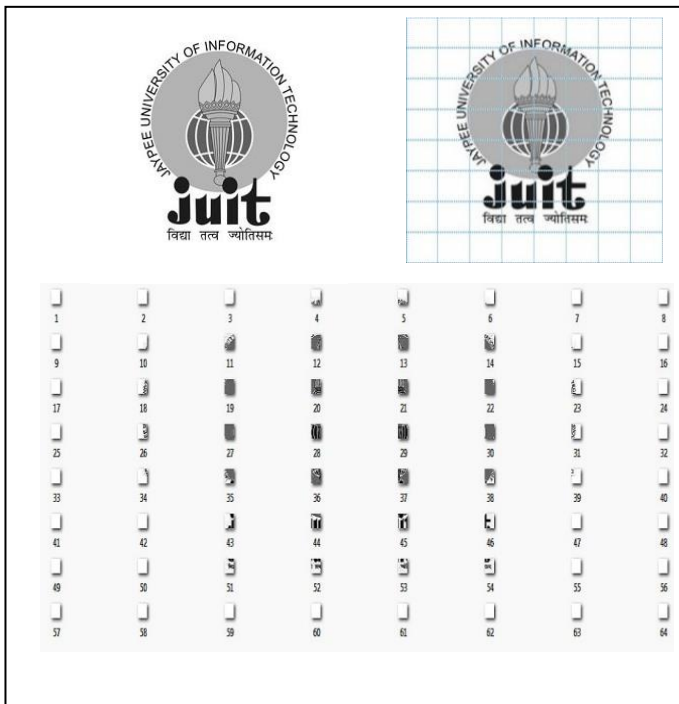

Figure 2: Watermark Preprocess

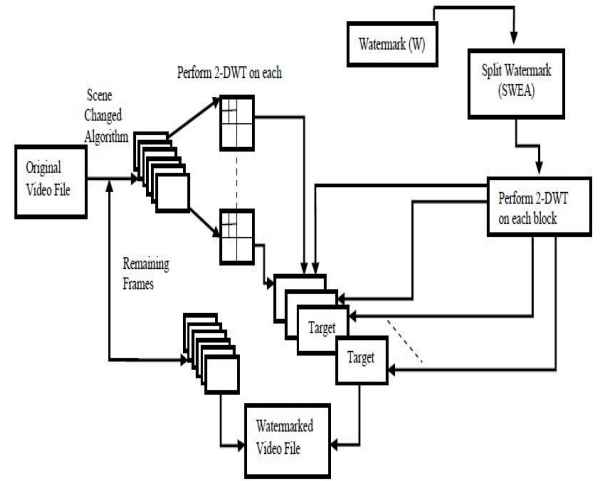

Figure 3. Video and watermark pre-process

A. ZPA (Zero Padding Algorithm) Embedding Algorithm

1. **Input** Original video sequence (O_{video}) and Watermark (W) [256, 256]
2. Extract scene changed frame (I) Total number of scene changed frames= m
3. **Splits the watermark into small pieces** while $m \geq 4^n$

$$\text{size of watermark blocks } Wb(x,y) = \left[\frac{256}{\sqrt{4^n}} \times \frac{256}{\sqrt{4^n}} \right]$$

4. Take 2-level 2-dimensional DWT of I_i for $i = 1 : m$
 $[Ca_i, Ch_i, Cv_i, Cd_i] = \text{DWT2}(I_i, \text{"haar"})$
 $j=i+1$
 $[Ca_j, Ch_j, Cv_j, Cd_j] = \text{DWT2}(Ca_i, \text{"haar"})$
 Calculate size of Ca_j
 $[p \ q] = \text{size}(Ca_j)$

5. ZERO PADDING in watermark block
 $Z = \text{zeros}(p,q)$ and size of $Wb = [x \ y]$
 Insert the values of Wb in Z

$$\text{Row value insertion at } Z \left(\frac{p-x}{2} + 1 : \frac{p-x}{2} + x \right)$$

$$\text{Column value insertion at } Z \left(\frac{q-y}{2} + 1 : \frac{q+y}{2} \right)$$

Now, Zero padded watermark = ZW

6. Insert the zero padded watermark ZW into Ca_j
7. Now new coefficients will be
 $\text{mod } Ca_i, \text{ mod } Ca_j$
 Take IDWT of modified coefficients
8. Finally get the zero padded watermarked frame (EW_f) and watermarked video (EW_{video})

B. Detection Algorithm

1. Input watermarked video (EW_{video}) and Original Video (O_{video})

2. Take watermarked frame (EW_f) from (EW_{video})
- Original frame (I_i) from (O_{video})
3. Subtract 1-level approximate coefficients of watermarked image (EW_f) from the 1-level approximate coefficients of I-frame (I_i)
Now, $NewCa_i = \text{mod } Ca_i - Ca_i$
4. Calculate cross correlation between $NewCa_i$ and original watermark block
if correlation = = high
Then, Stop the execution. Detected watermark block is similar to original watermark block.
else if
Take 2-level approximate coefficients and repeat from step 3 until the detected watermark will get similarity with original watermark.
else
Watermark not found.

detailed coefficients of 2nd level. Same as in figure 5(b). After embedding the first block of the watermark from figure 2(c) in LL-2 of figure 4(b), take IDWT (Inverse discrete wavelet transform) of 4(b) that is shown in Figure 6.

III. EXPERIMENTAL RESULTS AND ANALYSIS

To implement this technique, original videos 'foreman.yuv' and 'car_race.mp4' at the dimension of 288 x 352 and 640 x 360 are used respectively and the size of original watermark image is 256 x 256. Figure 4 and 5 show original video frames (foreman.yuv and car_race.mp4 respectively) and their 2-Level de-compositions.



Figure 4 (a): Original foreman video frame

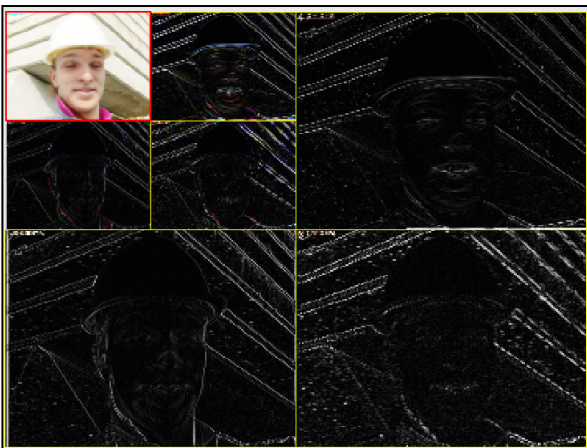

Figure 4 (b): 2-level decomposition of foreman video

In figure 4(b), there are two types of rectangle blocks, the first one is (144 x 176) named as [LL-1 LH-1 HL-1 HH-1] and second (72 x 88) named as [LL-2 LH-2 HL-2 HH-2]. LL-2 is known as the approximate coefficient of 2nd level where embed the watermark information and rest are



Figure 5 (a): Original car race video frame



Figure 5 (b): 2-level decomposition of car race video



Figure 6 (a): Watermarked foreman video frame



Figure 6 (b): Watermarked car race video frame

Applied watermark detection algorithm on all the watermarked I-frames e.g. Figure 6(a) & 6(b) and collect all the small pieces of watermark picture. If the PSNR (Peak Signal to Noise Ratio) of watermarked video is high, it means the original and watermarked videos are same. So

watermark is invisible. In Table I, the average, maximum and minimum PSNR of foreman video are calculated after embedding (8x8) watermark in all identical frames. Figure 7(a) shows extracted watermark blocks figure 7(b) shows the extracted watermark. Figures 8 and 9 show the robustness against spatial attack (Uniform Noise & Gaussian Noise) and temporal attacks (Frame swapping & Frame repetition) and compare results with [6] and [7].

Table 1
Video PSNR (in dB) after Watermarking

Sequence	Average PSNR	Maximum PSNR	Minimum PSNR
Foreman	53.29	59.14	50.31
Car race	50.09	56.64	49.85

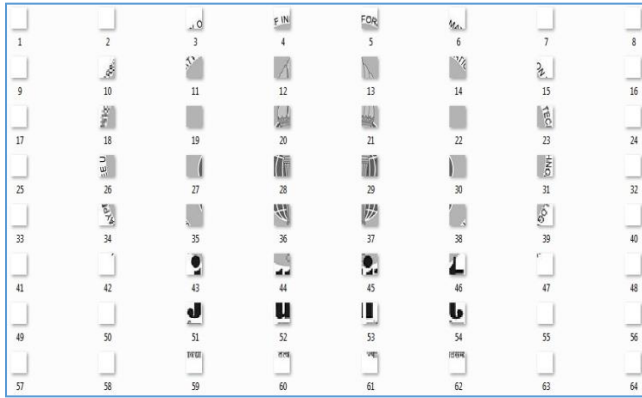

Figure 7 (a): Extracted watermark block in foreman video



Figure 7(b). Extracted Watermark

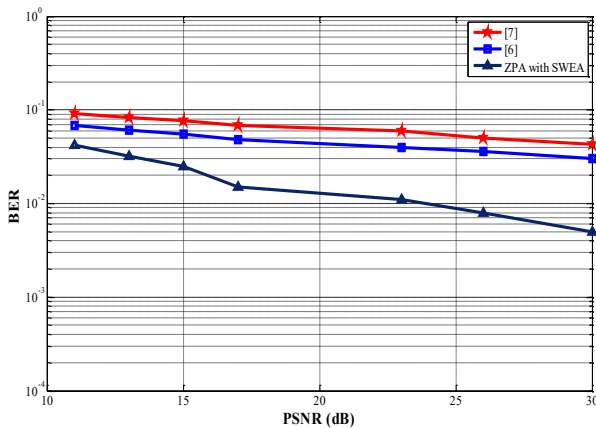

Figure 8. BER (log scale) under spatial attack (Uniform noise)

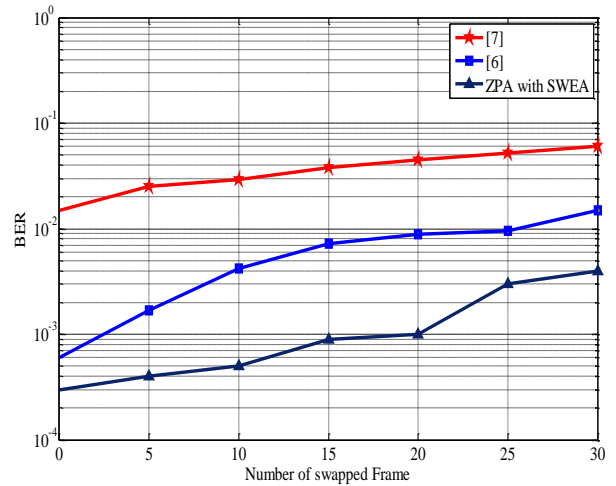

Figure 9. BER (log scale) under temporal attack (Frame Swapping)

IV. CONCLUSION

Video watermarking is an essential need of copyright protection and a lot of research is still going on to find out the new methods for security and privacy of the multimedia contents. Current methods for video copyright protection techniques are extended form of image watermarking and there is a great scope of innovation. The proposed approach is more proficient because the quality of extracted watermark is better than [6,7] in terms of PSNR and BER. The proposed technique provides a great security to watermark, because no one can get the original pattern of inserted watermark and it also reduces the inserting bits as in the form of a watermark. ZPA also offers high level transparency between original and watermarked video. Research can be carried out to establish new strategies for digital video copyright protection.

REFERENCES

- [1] P. Totcharova, et al, "The ABC of Copyright" in International Copyright and Related Right Protection by United Nation Educational Scientific and Cultural Organization.
- [2] C. Langlaar, et al, "Watermarking Digital Image and Video Data", in IEEE Signal Processing Magazine, September 2000.
- [3] I. J. Cox, et al, "Digital Watermarking and Steganography," in 2nd ed. San Mateo, CA, USA: Morgan Kaufman, 2008.
- [4] H. Huang, et al., "A video watermarking technique based on pseudo-3D DCT and quantization index modulation," *IEEE Trans. Inf. Forensics Security*, vol. 5, no. 4, pp. 625–637, Dec. 2010.
- [5] S. Bhattacharya, et al, "A survey on different video watermarking techniques and comparative analysis with reference to h. 264/avc," in *IEEE Tenth International Symposium on Consumer Electronics, ISCE'06*. IEEE, pp. 1–6, 2006.
- [6] H. Khalilian, et al, "Multiplicative video watermarking with semi-blind maximum likelihood decoding for copyright protection," in *Proc. IEEE Pacific Rim Conf. Commun., Comput. Signal Process.*, pp. 125–130, Aug. 2011.
- [7] A. Murshid, et al, "Blind compressed video watermarking in DCT domain robust against global geometric attacks. *Proceeding of the International Cryptology Workshop and Conference*, 2008.
- [8] H. Khalilian, et al, "Digital video watermarking in 3D ridgelet domain," in *Proc. 11th ICACT*, vol. 3, pp. 1643–1646, Feb. 2009.
- [9] S. Gandhe, et al, "Dual watermarking in video using discrete wavelet transform," in *Second International Conference on Machine Vision, ICMV '09*, pp. 216 –219, Dec. 2009.
- [10] B Shahraray "Scene Change Detection and Content-Based Sampling of Video Sequences," in *SPIE 2419 (Digital Video Compression: Algorithms and Technologies)*: 2–13, 1995

- [11] P. Campisi, *et al*, "Perceptual video watermarking in the 3D-DWT domain using a multiplicative approach," in *Lecture Notes in Computer Science*, vol. 3710. New York, NY, USA: Springer-Verlag, pp. 432–443, Sep. 2005.
- [12] P.W. Chan, *et al*, "A DWT-based Digital Video Watermarking Scheme with Error Correcting Code," In *Proceedings Fifth International Conference on Information and Communications Security (ICICS2003)*, Lecture Notes in Computer Science, Springer, Vol. 2836, pp. 202-213, Huhehaote City, Inner-Mongolia, China, Oct. 10-13, 2003.
- [13] B. Yeo, *et al*, "Rapid scene change detection on compressed video," in *IEEE Trans. Circuits Syst. Video Technol.*, vol. 5, no. 6, pp. 533–544, Dec. 1995.
- [14] F. Hartung and, *et al*, "Watermarking of uncompressed and compressed video," in *Signal Process.*, vol. 66, no. 3, pp. 283–301, May 1998.
- [15] A. Hampapur, *et al*, "Digital Video Segmentation," In: *Limb J, Blatner M (eds) Proc Second Annual ACM Multimedia Conference and Exposition*, ACM, New York, NY, USA, pp 357–364, 1994.
- [16] M. A. Akhaee, *et al*, "Contourlet based image watermarking using optimum detector in a noisy environment," *IEEE Trans. Image Process.*, vol. 19, no. 4, pp. 967–980, Apr. 2010.
- [17] M. M., *et al* "Efficient Matching and Clustering of Video," in *IEEE International conference on image processing*, vol. 1, Piscataway, NJ, USA, 338-341, Oct. 1995.
- [18] J. Y. Park, *et al*, "Invertible Semi-fragile Watermarking Algorithm Distinguishing MPEG-2 Compression from Malicious Manipulation", *International Conference on Consumer Electronics*, pp. 18-19, June 2002.
- [19] J. Shieh, *et al*, "A semi-blind digital watermarking scheme based on singular value decomposition," *Comput. Stand. Inter.*, vol. 28, no. 4, pp. 428–440, Apr. 2006.
- [20] T. Al-Khatib, *et al*, "A Robust Video Watermarking Algorithm," in *Journal of Computer Science*, 4(11):6-9.1280, 2004.
- [21] B. Ming, "Digital watermarking embedding and attacking," in *Science and technology information*, pp (8):50~51, 2008.
- [22] Y. Wang, *et al*, "A wavelet-based watermarking algorithm for ownership verification of digital images," *IEEE Trans. Image Process*, vol. 11, no. 2, pp. 77–88, Feb. 2002.
- [23] Wang, Y., *et al*, "A Blind MPEG-2 video watermarking robust against geometric attacks: a set of approaches in DCT domain," in *IEEE Trans. Image Process*, **15**(6), 1536–1543, 2006.
- [24] Lin, *et al*, "An embedded watermark technique in video for copyright protection," in *Proc. Int. Conf. Pattern Recog.* 4, 795–798, 2006.