

Implementation of Smart Home Security System

Project Report submitted in partial fulfillment of the requirement

for the degree of

Bachelor of Technology

in

Computer Science Engineering

under the Supervision of

Brig. (Retd.) Prof. Dr. S.P. Ghreera

By

Akshay Goel (101339)

to



Jaypee University of Information and Technology

Waknaghat, Solan – 173234, Himachal Pradesh

CERTIFICATE

This is to certify that the work entitled “**Implementation of smart Home Security System**” submitted by **Akshay Goel(101339)**, in partial fulfillment for the award of degree of **Bachelor of Technology** of Jaypee University of Information Technology, Waknaghat has been carried out under my supervision.

This work has not been submitted partially or wholly to any other University or Institute for the award of this or any other degree or diploma.

Signature of Guide:

Name of Guide: **Brig. (Retd.) Prof. Dr. S.P. Ghrera**

Designation: **Head of Department**

Date:

ACKNOWLEDGEMENT

This project could not have been at the stage it is right now had it not been for the cooperation of Brig. (Retd.) Prof. Dr. S.P. Ghrrera, our project guide, who was always there to tell us how to go about our project in a systematic manner and who always took out time to help us with our technical and non-technical doubts at various stages of the project.

Equally important was the contribution of Dr. Hemraj Saini, our project supervisor, who kept faith in our ability to complete the project well and on time.

Last but not the least; it was the teachers of the Jaypee University of Information Technology, Wagnaghat, who came to our rescue whenever we got stuck in any piece of code or otherwise.

ABSTRACT:

With the help of microcontroller and its interfacing, I aim to modularize a smart security system that would focus on areas such as alarm system based on PIR sensor, Magnetic sensor, GSM and password protection. An LED is attached to the circuit for the display. Buzzer is also attached with the circuit in order to alert the user. The message gets displayed on the screen if someone enters the house without permission.

Signature of Student:

Name:

Date:

Signature of Supervisor:

Name:

Date

GSM based Home security system

TABLE OF CONTENTS

CHAPTER ONE: INTRODUCTION

- 1.1 Introduction
- 1.2 Methodology
- 1.3 Scope of Work
- 1.4 Aims of the Project
- 1.5 Objectives of the Project

CHAPTER TWO: THEORETICAL BACKGROUND AND LITERATURE REVIEW

- 2.0 GSM & GSM Module Introduction
- 3.0 PIR Sensor Introduction

CHAPTER THREE: DESIGN AND CONSTRUCTION

- 3.1 Component List
- 3.2 Power supply
 - 3.2.1 Transformer
 - 3.2.2 Diode
 - 3.2.3 Regulator

3.2.4 Capacitor filter

3.2.5 Circuit diagram power supply

3.3 LCD

3.4 LED

3.5 Registers

3.6 Capacitors

CHAPTER FOUR: SERIAL COMMUNICATION, PROGRAMMER, SIMULATOR, BURNER

4.1.1 Initializations

4.1.2 Serial transfer using TI and RI flags

4.2 Programmer

4.3 Simulator

CHAPTER FIVE: RECOMMENDATION AND CONCLUSION

5.1 Conclusion

5.2 Problems Encountered

5.2 Future Improvement

REFERENCES

APPENDIX A: USER'S MANUAL

APPENDIX B: TROUBLESHOOTING MANUAL

APPENDIX C: PROGRAM FLOWCODE

APPENDIX D: CONSTRUCTION STAGES

CHAPTER ONE

1.1

INTRODUCTION

Currently Security is a major Concern. Like in home any intruder, any hazard condition (Lock broken or presence of anybody in lock condition) and an authentic entry in the house. Detecting these hazards and giving an indication about them is very big task here in this project we will make a smart home that includes a Door magnetic sensor for sensing door lock condition and we are using PIR sensor in the home. We are also using a GSM module for sending SMS when any of condition becomes false. For example we are using a Magnetic sensor at door when we close the door and locked it if someone broke the lock and enter in house then magnetic sensor will give signal to microcontroller and it will send SMS on registered mobile number about door broken and also raise an alarm. Other condition is if somebody present in house when door is locked and system is on then PIR sensor sense it give signal to microcontroller and it will send SMS on registered mobile number about presence of some moving body in house and also raise an alarm.

1.2 Methodology

The method used to carry out this project is the principle of serial communication in GSM technology in collaboration with embedded systems. This is a very good project for Industries. This project has a GSM, PIR sensor & Magnetic Sensor, which is the latest technology used for Surveillance & monitoring. When any hazard condition detected by sensor then unit will send SMS on registered mobile number about condition and also raise an alarm.

1.3 Scope of Work

I will use 16*2 LCD for displaying the message. I am also using PIR sensor for sensing presence of moving body.

Aims of the Project

- ✓ **Uses:** This project will provide High security to our Home.

1.4 Objectives of the Project

- ✓ Programming of GSM Modem-SIM900A.
- ✓ Interfacing the programmable chip with the LCD.
- ✓ Interfacing of the PIR with the programmable chip
- ✓ Magnet sensor

CHAPTER TWO

THEORETICAL BACKGROUND AND LITERATURE REVIEW

2.0 GSM & GSM Module Introduction

The GSM system is the most widely used cellular technology in use in the world today. It has been a particularly successful cellular phone technology for a variety of reasons including the

ability to roam worldwide with the certainty of being able to be able to operate on GSM networks in exactly the same way - provided billing agreements are in place.

The letters GSM originally stood for the words Groupe Speciale Mobile, but as it became clear this cellular technology was being used world wide the meaning of GSM was changed to Global System for Mobile Communications. Since this cellular technology was first deployed in 1991, the use of GSM has grown steadily, and it is now the most widely cell phone system in the world. GSM reached the 1 billion subscriber point in February 2004, and is now well over the 3 billion subscriber mark and still steadily increasing.



System overview

The GSM system was designed as a second generation (2G) cellular phone technology. One of the basic aims was to provide a system that would enable greater capacity to be achieved than the previous first generation analogue systems. GSM achieved this by using a digital TDMA (time division multiple access approach). By adopting this technique more users could be accommodated within the available bandwidth. In addition to this, ciphering of the digitally encoded speech was adopted to retain privacy. Using the earlier analogue cellular technologies it

was possible for anyone with a scanner receiver to listen to calls and a number of famous personalities had been "eavesdropped" with embarrassing consequences.

GSM services

Speech or voice calls are obviously the primary function for the GSM cellular system. To achieve this speech is digitally encoded and later decoded using a vectored. A variety of vocoders are available for use, being aimed at different scenarios.

In addition to the voice services, GSM cellular technology supports a variety of other data services. Although their performance is nowhere near the level of those provided by 3G, they are nevertheless still important and useful. A variety of data services are supported with user data rates up to 9.6 kbps. Services including Group 3 facsimile, videotext and teletex can be supported.

One service that has grown enormously is the short message service. Developed as part of the GSM specification, it has also been incorporated into other cellular technologies. It can be thought of as being similar to the paging service but is far more comprehensive allowing bi-directional messaging, store and forward delivery, and it also allows alphanumeric messages of a reasonable length. This service has become particularly popular, initially with the young as it provided a simple, low fixed cost.

GSM basics

The GSM cellular technology had a number of design aims when the development started:

- It should offer good subjective speech quality
- It should have a low phone or terminal cost
- Terminals should be able to be handheld
- The system should support international roaming
- It should offer good spectral efficiency
- The system should offer ISDN compatibility

The resulting GSM cellular technology that was developed provided for all of these. The overall system definition for GSM describes not only the air interface but also the network or infrastructure technology. By adopting this approach it is possible to define the operation of the whole network to enable international roaming as well as enabling network elements from different manufacturers to operate alongside each other, although this last feature is not completely true, especially with older items.

GSM cellular technology uses 200 kHz RF channels. These are time division multiplexed to enable up to eight users to access each carrier. In this way it is a TDMA / FDMA system.

The base transceiver stations (BTS) are organised into small groups, controlled by a base station controller (BSC) which is typically co-located with one of the BTSs. The BSC with its associated BTSs is termed the base station subsystem (BSS).

Further into the core network is the main switching area. This is known as the mobile switching centre (MSC). Associated with it is the location registers, namely the home location register (HLR) and the visitor location register (VLR) which track the location of mobiles and enable

calls to be routed to them. Additionally there is the Authentication Centre (AuC), and the Equipment Identify Register (EIR) that are used in authenticating the mobile before it is allowed onto the network and for billing. The operation of these are explained in the following pages.

Last but not least is the mobile itself. Often termed the ME or mobile equipment, this is the item that the end user sees. One important feature that was first implemented on GSM was the use of a Subscriber Identity Module. This card carried with it the users identity and other information to allow the user to upgrade a phone very easily, while retaining the same identity on the network. It was also used to store other information such as "phone book" and other items. This item alone has allowed people to change phones very easily, and this has fuelled the phone manufacturing industry and enabled new phones with additional features to be launched. This has allowed mobile operators to increase their average revenue per user (ARPU) by ensuring that users are able to access any new features that may be launched on the network requiring more sophisticated phones.

Introduction to GSM Modem

SIM900A is a complete dual band GSM/GPRS solution. We have designed ready to use GSM Modem using this module with its simple serial TTL interface. This Modem featuring an

industry standard interface. It delivers GSM/GPRS 900/1800MHz performance for voice, SMS, Data and Fax in small form factor and low power consumption.

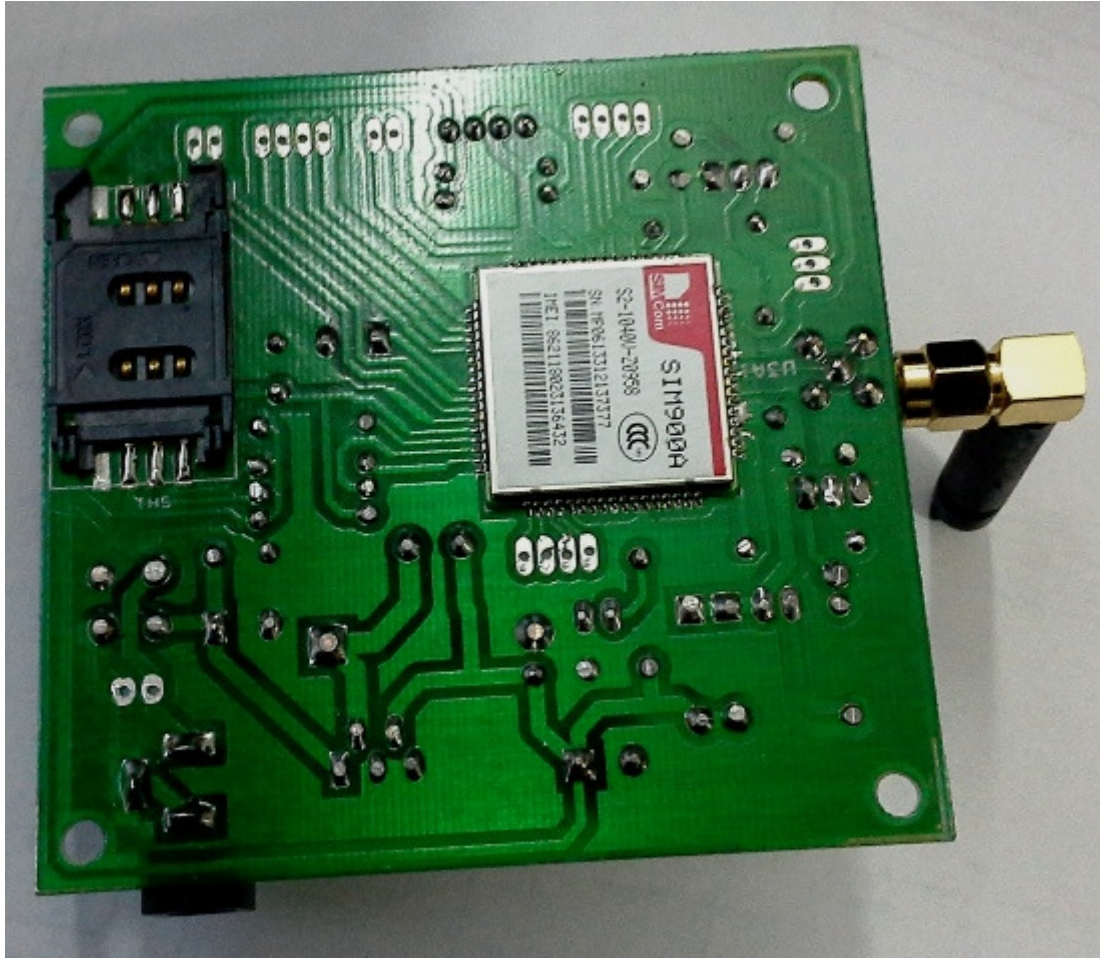

Note: Package included with Antenna & SMA Connector as in above picture

Features

- Dual Band 900/1800 MHz
- GPRS Multi-Slot class 10/8

- GPRS Mobile station class B
- Compliant to GSM Phase 2/2+
- Class 4 (2W @900 MHz)
- Class 1 (1W @1800 MHz)
- AT commands (GSM07.07,07.05 & SIMCOM enhanced AT Commands)
- SIM application tool kit
- Direct connection to microcontroller

Applications

- Security & Surveillance system
- Smart home system
- Data logging & transfer system
- Water pump control system
- Robot control system

Modem Specification

- Supply Voltage Range : 7V to 38V
- Operation Temperature : -40 to +85 Degree C

| PIN No | PIN Information |
|---------------|------------------------|
| | |

| PIN No | PIN Information |
|---------------|------------------------|
| DBX_RXD | Debug Receiver |
| DBX_TXD | Debug Transmitter |
| SPK_N | Speaker Negative |
| SPK_P | Speaker Positive |
| MIC_N | Microphone Negative |
| MIC_P | Microphone Positive |
| RESET | Reset |
| VDD_EXT | VDD External |
| 5V | 5 Volt Supply (OUT) |
| GND | Ground |
| RX | TTL Receiver |
| TX | TTL Transmitter |
| RTS | Request to send |

| PIN No | PIN Information |
|---------------|------------------------|
| CTS | Clear to send |
| DCD | - |
| DTR | - |
| RI | Ring |
| PWR_KEY | Power Key |
| Status | Status |

3.0 PIR sensor Introduction

PIR sensors allow you to sense motion, almost always used to detect whether a human has moved in or out of the sensors range. They are small, inexpensive, low-power, easy to use and don't wear out. For that reason they are commonly found in appliances and gadgets used in homes or businesses. They are often referred to as PIR, "Passive Infrared", "Pyroelectric", or "IR motion" sensors.

PIRs are basically made of a pyroelectric sensor (which you can see above as the round metal can with a rectangular crystal in the center), which can detect levels of infrared radiation. Everything emits some low level radiation, and the hotter something is, the more radiation is emitted. The sensor in a motion detector is actually split in two halves. The reason for that is that we are looking to detect motion (change) not average IR levels. The two halves are wired up so that they cancel each other out. If one half sees more or less IR radiation than the other, the output will swing high or low.



How does it works

PIR sensors are more complicated than many of the other sensors explained in these tutorials (like photocells, FSRs and tilt switches) because there are multiple variables that affect the sensors input and output. To begin explaining how a basic sensor works, we'll use this rather nice diagram (if anyone knows where it originates plz let me know).

The PIR sensor itself has two slots in it, each slot is made of a special material that is sensitive to IR. The lens used here is not really doing much and so we see that the two slots can 'see' out past some distance (basically the sensitivity of the sensor). When the sensor is idle, both slots detect the same amount of IR, the ambient amount radiated from the room or walls or outdoors. If a warm body likes a human or animal passes by, it first intercepts one half of the PIR sensor, which causes a positive differential change between the two halves. When the warm body leaves the sensing area, the reverse happens, whereby the sensor generates a negative differential change. These change pulses are what is detected.

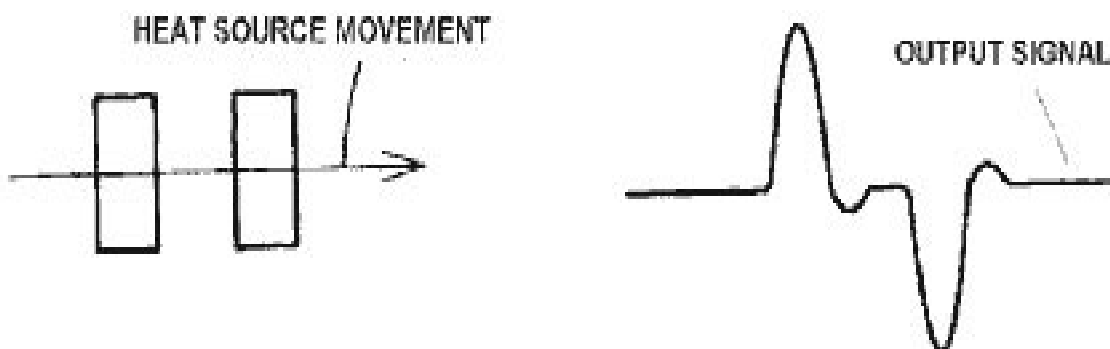
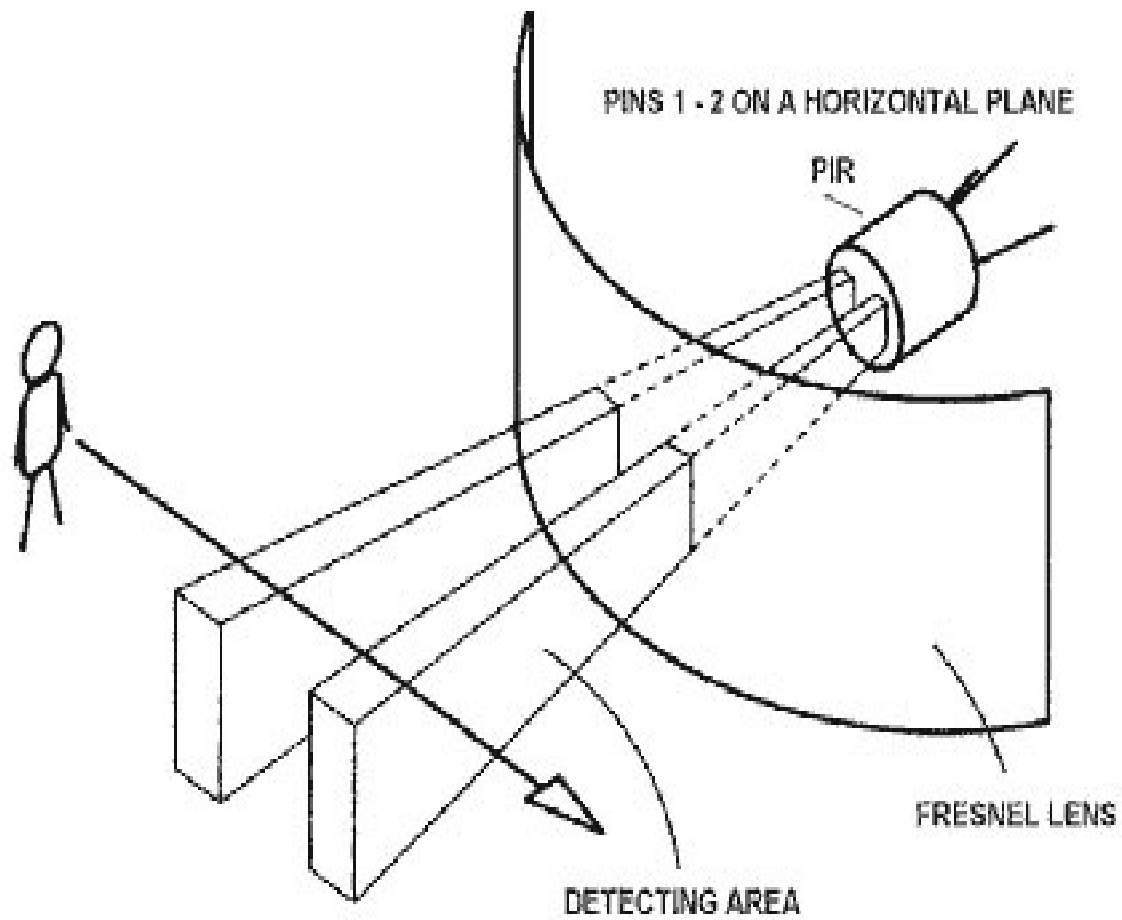

2.7 Circuit Diagram of the Project:-

CHAPTER THREE: CONSTRUCTION AND DESIGN

3.1 COMPONENTS LIST

| Home security system | | | |
|----------------------|--------------|----------|------|
| Name | Capacity | Quantity | Code |
| Regulator | 7805/LM317 | 1/1 | |
| Capacitor | 1000 μ f | 2 | |
| Capacitor | 10 μ f | 1 | |
| Ceramic Capacitor | 22pf | 2 | |
| Power Adopter | 12V/1A | 1 | |
| Push Button | | 2 | |
| GSM Modem | SIM900A | 1 | |
| PIR sensor | | 1 | |
| LCD | 16*2 | 1 | |
| 28 Pin Base | | 1 | |
| Atmega -8A | | 1 | |
| Oscillator | Internal | 1 | |
| LED | | 2 | |

| | | | |
|-----------------|------|---|--|
| Resistance | 220Ω | 3 | |
| Resistance | 1k | 1 | |
| Resistance | 10k | 2 | |
| Relay | | 1 | |
| Magnetic sensor | | 1 | |

3.2 POWER SUPPLY (Inside Adopter):

Power supply is a reference to a source of electrical power. A device or system that supplies electrical or other types of energy to an output load or group of loads is called a **power supply unit** or **PSU**. The term is most commonly applied to electrical energy supplies, less often to mechanical ones, and rarely to others.

Here in our application we need a 5v DC power supply for all electronics involved in the project. This requires step down transformer, rectifier, voltage regulator, and filter circuit for generation of 5v DC power. Here a brief description of all the components are given as follows:

3.2.1 TRANSFORMER:

A **transformer** is a device that transfers electrical energy from one circuit to another through inductively coupled conductors — the transformer's coils or "windings". Except for air-core transformers, the conductors are commonly wound around a single iron-rich core, or around separate but magnetically-coupled cores. A varying current in the first or "primary" winding creates a varying magnetic field in the core (or cores) of the transformer. This varying magnetic field induces a varying electromotive force (EMF) or "voltage" in the "secondary" winding. This effect is called mutual induction.

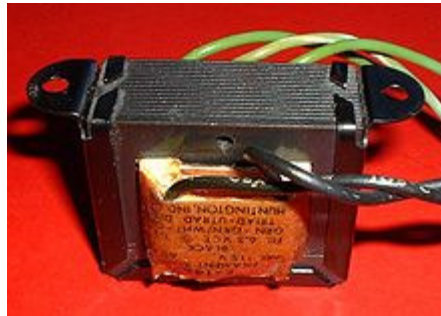

If a load is connected to the secondary circuit, electric charge will flow in the secondary winding of the transformer and transfer energy from the primary circuit to the load connected in the secondary circuit.

The secondary induced voltage V_S , of an ideal transformer, is scaled from the primary V_P by a factor equal to the ratio of the number of turns of wire in their respective windings:

$$\frac{V_S}{V_P} = \frac{N_S}{N_P}$$

By appropriate selection of the numbers of turns, a transformer thus allows an alternating voltage to be stepped up — by making N_S more than N_P — or stepped down, by making it

BASIC PARTS OF A TRANSFORMER

In its most basic form a transformer consists of:

- A primary coil or winding.
- A secondary coil or winding.
- A core that supports the coils or windings.

Refer to the transformer circuit in figure as you read the following explanation: The primary winding is connected to a 60-hertz ac voltage source. The magnetic field (flux) builds up (expands) and collapses (contracts) about the primary winding. The expanding and contracting magnetic field around the primary winding cuts the secondary winding and induces an alternating voltage into the winding. This voltage causes alternating current to flow through the load. The voltage may be stepped up or down depending on the design of the primary and secondary windings.

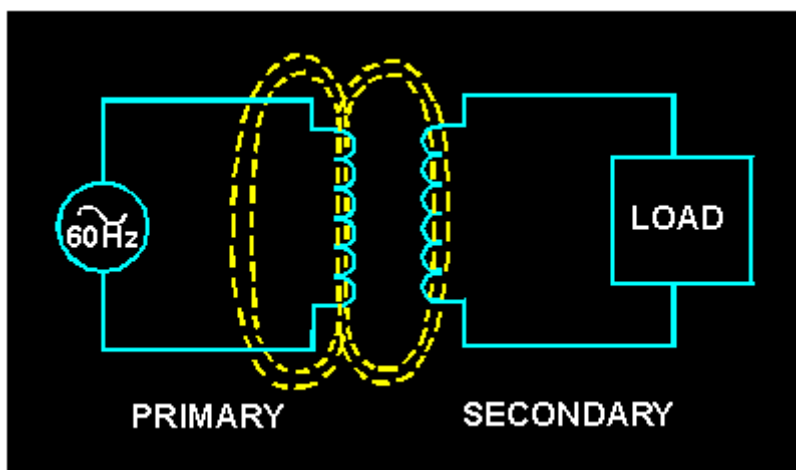

THE COMPONENTS OF A TRANSFORMER

Two coils of wire (called windings) are wound on some type of core material. In some cases the coils of wire are wound on a cylindrical or rectangular cardboard form. In effect, the core material is air and the transformer is called an AIR-CORE TRANSFORMER. Transformers used at low frequencies, such as 60 hertz and 400 hertz, require a core of low-reluctance magnetic material, usually iron. This type of transformer is called an IRON-CORE TRANSFORMER. Most power transformers are of the iron-core type. The principle parts of a transformer and their functions are:

- The CORE, which provides a path for the magnetic lines of flux.
- The PRIMARY WINDING, which receives energy from the ac source.
- The SECONDARY WINDING, which receives energy from the primary winding and delivers it to the load.
- The ENCLOSURE, which protects the above components from dirt, moisture, and mechanical damage.

BRIDGE RECTIFIER

A bridge rectifier makes use of four diodes in a bridge arrangement to achieve full-wave rectification. This is a widely used configuration, both with individual diodes wired as shown and with single component bridges where the diode bridge is wired internally.

BASIC OPERATION

According to the conventional model of current flow originally established by Benjamin Franklin and still followed by most engineers today, current is *assumed* to flow through electrical conductors from the **positive** to the **negative** pole. In actuality, free electrons in a conductor nearly always flow from the **negative** to the **positive** pole. In the vast majority of applications, however, the *actual* direction of current flow is irrelevant. Therefore, in the discussion below the conventional model is retained.

In the diagrams below, when the input connected to the **left** corner of the diamond is **positive**, and the input connected to the **right** corner is **negative**, current flows from the **upper** supply terminal to the right along the **red** (positive) path to the output, and returns to the **lower** supply terminal via the **blue** (negative) path.

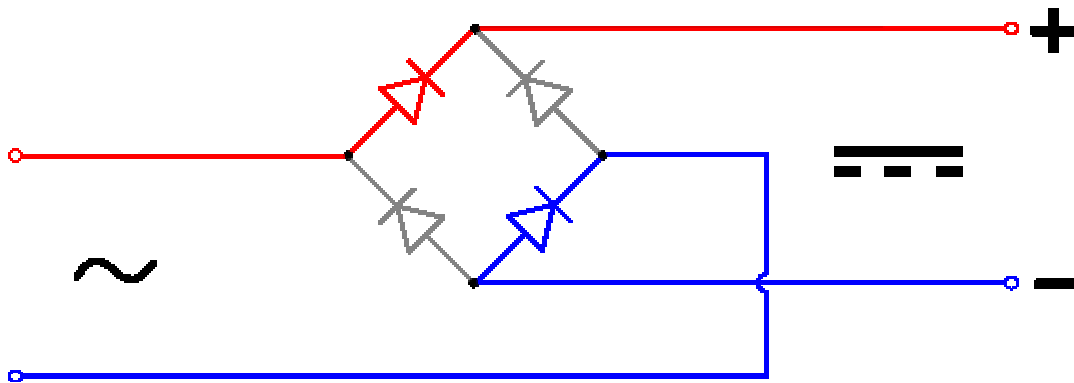

When the input connected to the **left** corner is **negative**, and the input connected to the **right** corner is **positive**, current flows from the **lower** supply terminal to the right along the **red** path to the output, and returns to the **upper** supply terminal via the **blue** path.

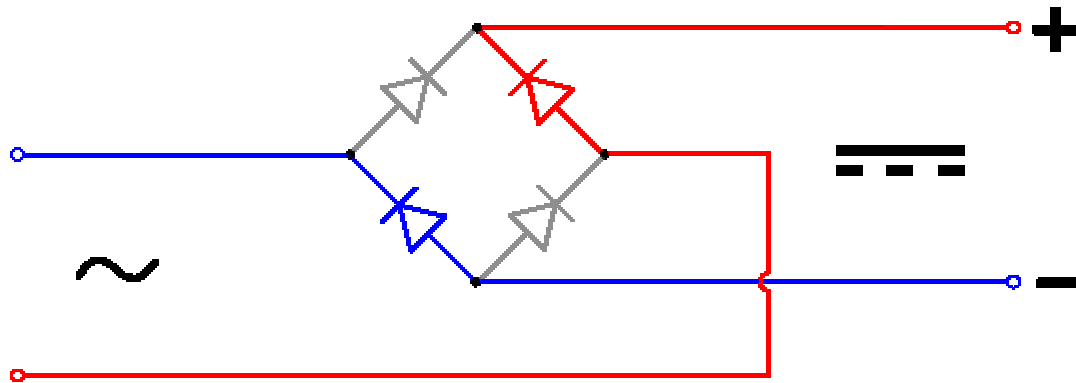

In each case, the upper right output remains positive and lower right output negative. Since this is true whether the input is AC or DC, this circuit not only produces a DC output from an AC input, it can also provide what is sometimes called "reverse polarity protection". That is, it permits normal functioning of DC-powered equipment when batteries have been installed backwards, or when the leads (wires) from a DC power source have been reversed, and protects the equipment from potential damage caused by reverse polarity.

Prior to availability of integrated electronics, such a bridge rectifier was always constructed from discrete components. Since about 1950, a single four-terminal component containing the four diodes connected in the bridge configuration became a standard commercial component and is now available with various voltage and current ratings.

OUTPUT SMOOTHING

For many applications, especially with single phase AC where the full-wave bridge serves to convert an AC input into a DC output, the addition of a capacitor may be desired because the

bridge alone supplies an output of fixed polarity but continuously varying or "pulsating" magnitude (see diagram above).

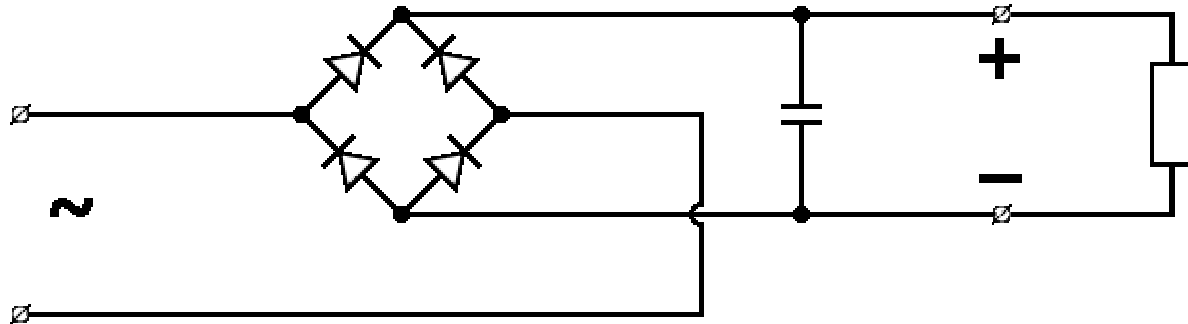

The function of this capacitor, known as a reservoir capacitor (or smoothing capacitor) is to lessen the variation in (or 'smooth') the rectified AC output voltage waveform from the bridge. One explanation of 'smoothing' is that the capacitor provides a low impedance path to the AC component of the output, reducing the AC voltage across, and AC current through, the resistive load. In less technical terms, any drop in the output voltage and current of the bridge tends to be canceled by loss of charge in the capacitor. This charge flows out as additional current through the load. Thus the change of load current and voltage is reduced relative to what would occur without the capacitor. Increases of voltage correspondingly store excess charge in the capacitor, thus moderating the change in output voltage / current.

The simplified circuit shown has a well-deserved reputation for being dangerous, because, in some applications, the capacitor can retain a *lethal* charge after the AC power source is removed. If supplying a dangerous voltage, a practical circuit should include a reliable way to safely discharge the capacitor. If the normal load cannot be guaranteed to perform this function, perhaps because it can be disconnected, the circuit should include a bleeder resistor connected as

close as practical across the capacitor. This resistor should consume a current large enough to discharge the capacitor in a reasonable time, but small enough to minimize unnecessary power waste.

Because a bleeder sets a minimum current drain, the regulation of the circuit, defined as percentage voltage change from minimum to maximum load, is improved. However in many cases the improvement is of insignificant magnitude.

The capacitor and the load resistance have a typical time constant $\tau = RC$ where C and R are the capacitance and load resistance respectively. As long as the load resistor is large enough so that this time constant is much longer than the time of one ripple cycle, the above configuration will produce a smoothed DC voltage across the load.

In some designs, a series resistor at the load side of the capacitor is added. The smoothing can then be improved by adding additional stages of capacitor-resistor pairs, often done only for sub-supplies to critical high-gain circuits that tend to be sensitive to supply voltage noise.

The idealized waveforms shown above are seen for both voltage and current when the load on the bridge is resistive. When the load includes a smoothing capacitor, both the voltage and the current waveforms will be greatly changed. While the voltage is smoothed, as described above, current will flow through the bridge only during the time when the input voltage is greater than the capacitor voltage. For example, if the load draws an average current of n Amps, and the diodes conduct for 10% of the time, the average diode current during conduction must be $10n$ Amps. This non-sinusoidal current leads to harmonic distortion and a poor power factor in the AC supply.

In a practical circuit, when a capacitor is directly connected to the output of a bridge, the bridge diodes must be sized to withstand the current surge that occurs when the power is turned on at the peak of the AC voltage and the capacitor is fully discharged. Sometimes a small series resistor is included before the capacitor to limit this current, though in most applications the power supply transformer's resistance is already sufficient.

Output can also be smoothed using a choke and second capacitor. The choke tends to keep the current (rather than the voltage) more constant. Due to the relatively high cost of an effective choke compared to a resistor and capacitor this is not employed in modern equipment.

Some early console radios created the speaker's constant field with the current from the high voltage ("B +") power supply, which was then routed to the consuming circuits, (permanent magnets were then too weak for good performance) to create the speaker's constant magnetic field. The speaker field coil thus performed 2 jobs in one: it acted as a choke, filtering the power supply, and it produced the magnetic field to operate the speaker.

3.2.2 Diode



A diode is a semiconductor device which allows current to flow through it in only one direction. Although a transistor is also a semiconductor device, it does not operate the way a diode does. A diode is specifically made to allow current to flow through it in only one direction. Some ways in which the diode can be used are listed here.

- A diode can be used as a rectifier that converts AC (Alternating Current) to DC (Direct Current) for a power supply device.

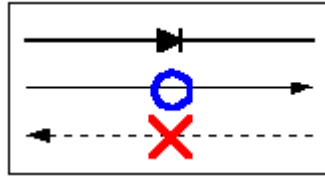
- Diodes can be used to separate the signal from radio frequencies.
- Diodes can be used as an on/off switch that controls current.



Diode Symbol

This symbol  is used to indicate a diode in a circuit diagram. The meaning of the symbol is (Anode)  (Cathode).

Current flows from the anode side to the cathode side.

Although all diodes operate with the same general principle, there are different types suited to different applications. For example, the following devices are best used for the applications noted.

Voltage regulation diode (Zener Diode)

The circuit symbol is .

It is used to regulate voltage, by taking advantage of the fact that Zener diodes tend to stabilize at a certain voltage when that voltage is applied in the opposite direction.

Light emitting diode

The circuit symbol is .

This type of diode emits light when current flows through it in the forward direction. (Forward biased)

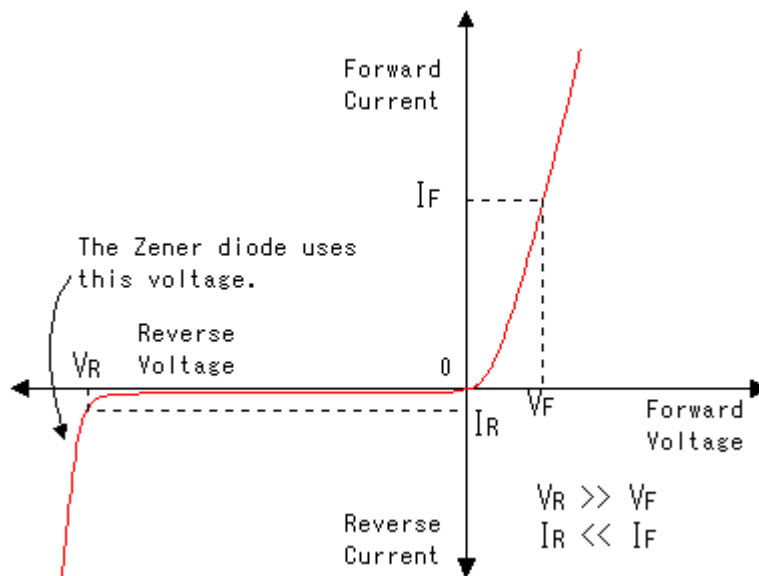

Characteristics of Diode

The graph above shows the electrical characteristics of a typical diode. When a small voltage is applied to the diode in the forward direction, current flows easily. Because the diode has a certain amount of resistance, the voltage will drop slightly as current flows through the diode. A typical diode causes a voltage drop of about 0.6 - 1V (V_F) (In the case of silicon diode, almost 0.6V)

This voltage drop needs to be taken into consideration in a circuit which uses many diodes in series. Also, the amount of current passing through the diodes must be considered.

When voltage is applied in the reverse direction through a diode, the diode will have a great resistance to current flow. Different diodes have different characteristics when reverse-biased. A given diode should be selected depending on how it will be used in the circuit. The current that will flow through a diode biased in the reverse direction will vary from several mA to just μA , which is very small.

The limiting voltages and currents permissible must be considered on a case by case basis. For example, when using diodes for rectification, part of the time they will be required to withstand a reverse voltage. If the diodes are not chosen carefully, they will break down.

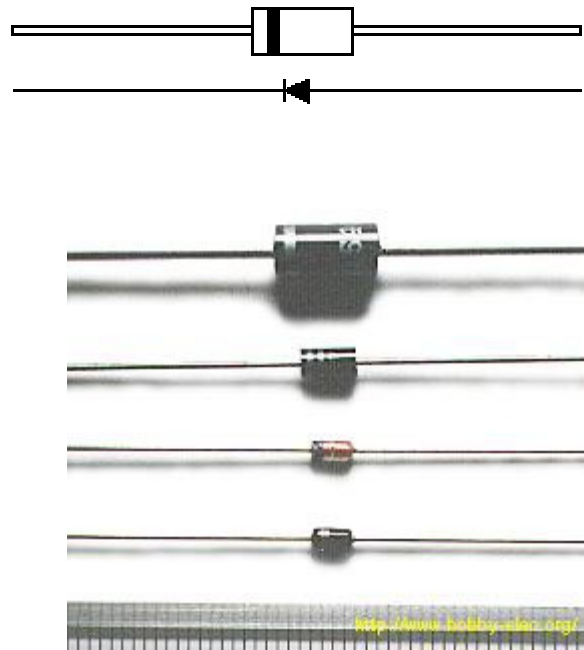

3.2.3 REGULATOR IC (78XX)

It is a three pin IC used as a voltage regulator. It converts unregulated DC current into regulated DC current.



Normally we get fixed output by connecting the voltage regulator at the output of the filtered DC (see in above diagram). It can also be used in circuits to get a low DC voltage from a high DC voltage (for example we use 7805 to get 5V from 12V). There are two types of voltage regulators 1. fixed voltage regulators (78xx, 79xx) 2. variable voltage regulators (LM317) In fixed voltage regulators there is another classification 1. +ve voltage regulators 2. -ve voltage regulators

POSITIVE VOLTAGE REGULATORS This include 78xx voltage regulators. The most commonly used ones are 7805 and 7812. 7805 gives fixed 5V DC voltage if input voltage is in (7.5V, 20V).

3.2.3 The CAPACITOR FILTER

The simple capacitor filter is the most basic type of power supply filter. The application of the simple capacitor filter is very limited. It is sometimes used on extremely high-voltage, low-current power supplies for cathode ray and similar electron tubes, which require very little load current from the supply. The capacitor filter is also used where the power-supply ripple frequency is not critical; this frequency can be relatively high. The capacitor (C1) shown in figure 4-15 is a simple filter connected across the output of the rectifier in parallel with the load.

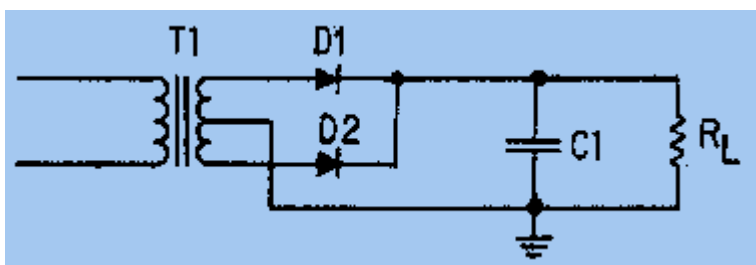

Full-wave rectifier with a capacitor filter.

When this filter is used, the RC charge time of the filter capacitor (C1) must be short and the RC discharge time must be long to eliminate ripple action. In other words, the capacitor must charge up fast, preferably with no discharge at all. Better filtering also results when the input frequency is high; therefore, the full-wave rectifier output is easier to filter than that of the half-wave rectifier because of its higher frequency.

For you to have a better understanding of the effect that filtering has on E_{avg} , a comparison of a rectifier circuit with a filter and one without a filter is illustrated in views A and B of figure 4-16. The output waveforms in figure 4-16 represent the unfiltered and filtered outputs of the half-wave rectifier circuit. Current pulses flow through the load resistance (R_L) each time a diode conducts. The dashed line indicates the average value of output voltage. For the half-wave rectifier, E_{avg} is less than half (or approximately 0.318) of the peak output voltage. This value is still much less than that of the applied voltage. With no capacitor connected across the output of the rectifier circuit, the waveform in view A has a large pulsating component (ripple) compared with the average or dc component. When a capacitor is connected across the output (view B), the average value of output voltage (E_{avg}) is increased due to the filtering action of capacitor C1.

UNFILTERED

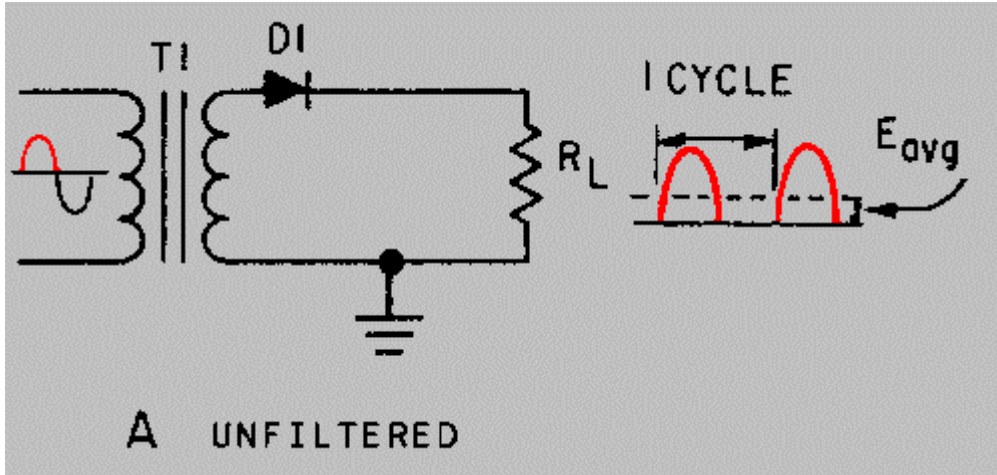

Half-wave rectifier with and without filtering.

FILTRE

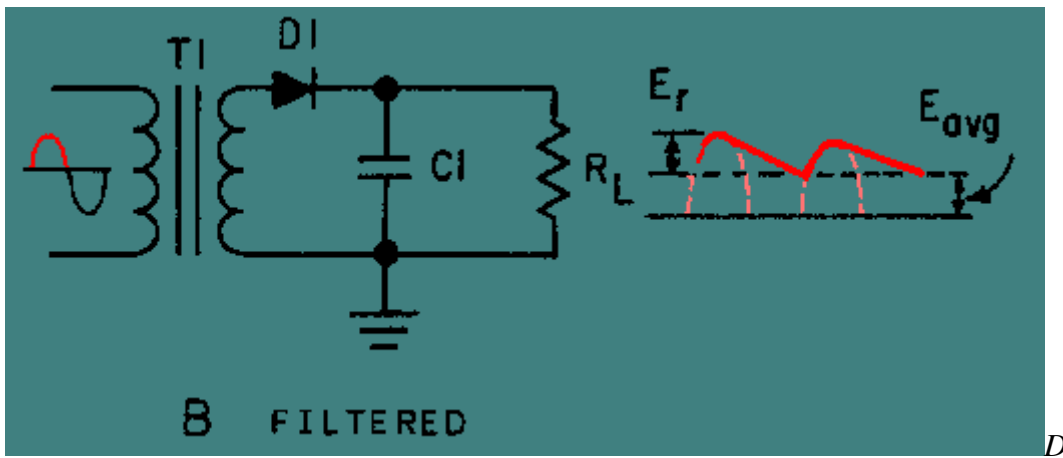

The value of the capacitor is fairly large (several microfarads), thus it presents a relatively low reactance to the pulsating current and it stores a substantial charge.

The rate of charge for the capacitor is limited only by the resistance of the conducting diode, which is relatively low. Therefore, the RC charge time of the circuit is relatively short. As a result, when the pulsating voltage is first applied to the circuit, the capacitor charges rapidly and almost reaches the peak value of the rectified voltage within the first few cycles. The capacitor attempts to charge to the peak value of the rectified voltage anytime a diode is conducting, and tends to retain its charge when the rectifier output falls to zero. (The capacitor cannot discharge immediately.) The capacitor slowly discharges through the load resistance (R_L) during the time the rectifier is non-conducting.

The rate of discharge of the capacitor is determined by the value of capacitance and the value of the load resistance. If the capacitance and load-resistance values are large, the RC discharge time for the circuit is relatively long.

A comparison of the waveforms shown in figure 4-16 (view A and view B) illustrates that the addition of C1 to the circuit results in an increase in the average of the output voltage (E_{avg}) and a reduction in the amplitude of the ripple component (E_r) which is normally present across the load resistance.

Now, let's consider a complete cycle of operation using a half-wave rectifier, a capacitive filter (C1), and a load resistor (R_L). As shown in view A of figure 4-17, the capacitive filter (C1) is assumed to be large enough to ensure a small reactance to the pulsating rectified current. The resistance of R_L is assumed to be much greater than the reactance of C1 at the input frequency. When the circuit is energized, the diode conducts on the positive half cycle and current flows

through the circuit, allowing C1 to charge. C1 will charge to approximately the peak value of the input voltage. (The charge is less than the peak value because of the voltage drop across the diode (D1)). In view A of the figure, the heavy solid line on the waveform indicates the charge on C1. As illustrated in view B, the diode cannot conduct on the negative half cycle because the anode of D1 is negative with respect to the cathode. During this interval, C1 discharges through the load resistor (R_L). The discharge of C1 produces the downward slope as indicated by the solid line on the waveform in view B. In contrast to the abrupt fall of the applied ac voltage from peak value to zero, the voltage across C1 (and thus across R_L) during the discharge period gradually decreases until the time of the next half cycle of rectifier operation. Keep in mind that for good filtering, the filter capacitor should charge up as fast as possible and discharge as little as possible.

Figure 4-17A. - Capacitor filter circuit (positive and negative half cycles). POSITIVE HALF-CYCLE

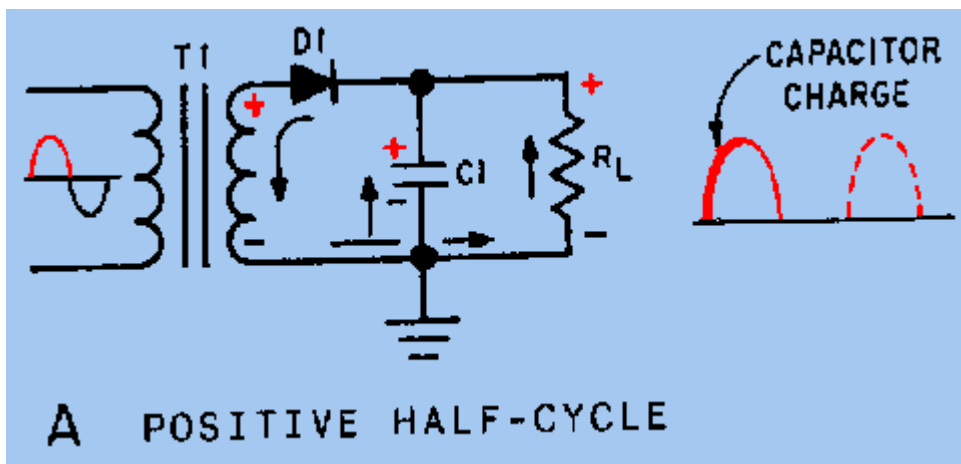

Capacitor filter circuit (positive and negative half cycles). NEGATIVE HALF-CYCLE

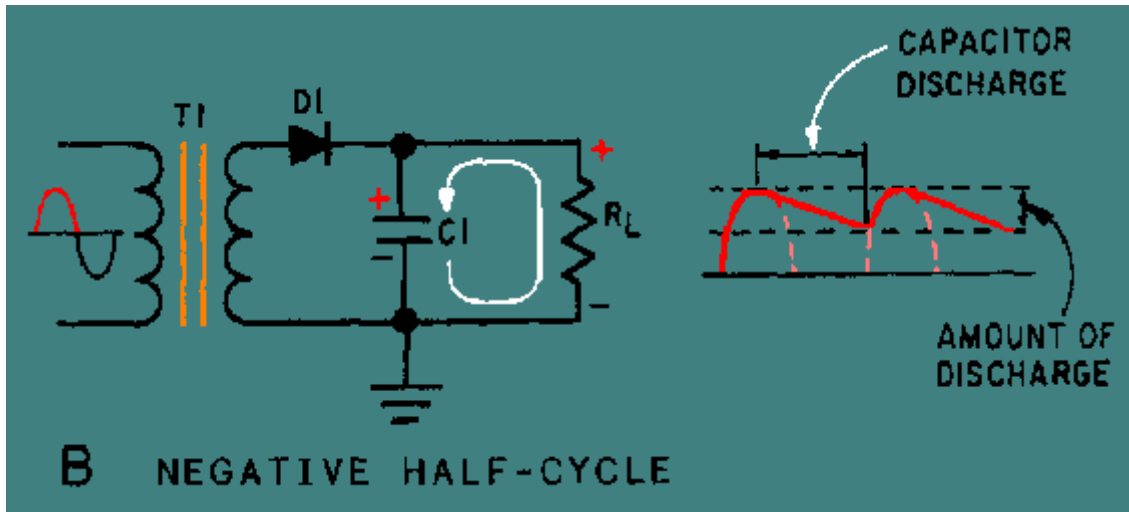

Since practical values of C_1 and R_L ensure a more or less gradual decrease of the discharge voltage, a substantial charge remains on the capacitor at the time of the next half cycle of operation. As a result, no current can flow through the diode until the rising ac input voltage at the anode of the diode exceeds the voltage on the charge remaining on C_1 . The charge on C_1 is the cathode potential of the diode. When the potential on the anode exceeds the potential on the cathode (the charge on C_1), the diode again conducts, and C_1 begins to charge to approximately the peak value of the applied voltage.

After the capacitor has charged to its peak value, the diode will cut off and the capacitor will start to discharge. Since the fall of the ac input voltage on the anode is considerably more rapid than the decrease on the capacitor voltage, the cathode quickly become more positive than the anode, and the diode ceases to conduct.

Operation of the simple capacitor filter using a full-wave rectifier is basically the same as that discussed for the half-wave rectifier. Referring to figure 4-18, you should notice that because one of the diodes is always conducting on either alternation, the filter capacitor charges and

discharges during each half cycle. (Note that each diode conducts only for that portion of time when the peak secondary voltage is greater than the charge across the capacitor.)

Full-wave rectifier (with capacitor filter).

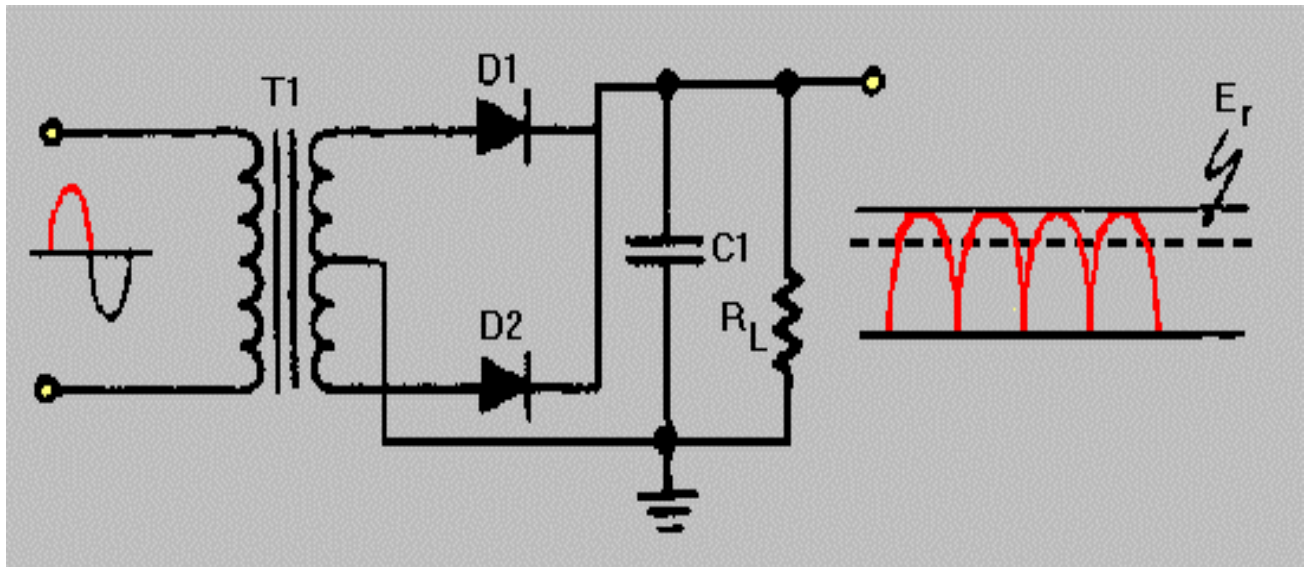

Another thing to keep in mind is that the ripple component (E_r) of the output voltage is an ac voltage and the average output voltage (E_{avg}) is the dc component of the output. Since the filter capacitor offers relatively low impedance to ac, the majority of the ac component flows through the filter capacitor. The ac component is therefore bypassed (shunted) around the load resistance, and the entire dc component (or E_{avg}) flows through the load resistance. This statement can be clarified by using the formula for X_C in a half-wave and full-wave rectifier. First, you must establish some values for the circuit.

HALFWAVE RECTIFIER

FREQUENCY AT
RECTIFIER OUTPUT: 60 Hz

VALUE OF FILTER
CAPACITOR: 30 μ F

LOAD RESISTANCE: 10k Ω

$$X_c = \frac{1}{2\pi fC}$$

$$X_c = \frac{.159}{fC}$$

$$X_c = \frac{.159}{60 \times .000030}$$

$$X_c = \frac{.159}{.0018}$$

$$X_c = 88.3\Omega$$

FREQUENCY AT
RECTIFIER OUTPUT: 120Hz

VALUE OF FILTER
CAPACITOR: 30 μ F

LOAD RESISTANCE: 10k Ω

$$X_C = \frac{1}{2\pi fC}$$

$$X_C = \frac{.159}{fC}$$

$$X_C = \frac{.159}{120 \times .000030}$$

$$X_C = \frac{.159}{.0036}$$

$$X_C = 44.16 \Omega$$

As you can see from the calculations, by doubling the frequency of the rectifier, you reduce the impedance of the capacitor by one-half. This allows the ac component to pass through the capacitor more easily. As a result, a full-wave rectifier output is much easier to filter than that of a half-wave rectifier. Remember, the smaller the X_C of the filter capacitor with respect to the load resistance, the better the filtering action. Since

$$X_C = \frac{1}{2\pi fC}$$

the largest possible capacitor will provide the best filtering.

Remember, also, that the load resistance is an important consideration. If load resistance is made small, the load current increases, and the average value of output voltage (E_{avg}) decreases. The RC discharge time constant is a direct function of the value of the load resistance; therefore, the rate of capacitor voltage discharge is a direct function of the current through the load. The greater the load current, the more rapid the discharge of the capacitor, and the lower the average value of output voltage. For this reason, the simple capacitive filter is seldom used with rectifier circuits that must supply a relatively large load current. Using the simple capacitive filter in conjunction with a full-wave or bridge rectifier provides improved filtering because the increased ripple frequency decreases the capacitive reactance of the filter capacitor.

3.2.5 CIRCUIT DIAGRAM OF POWER SUPPLY

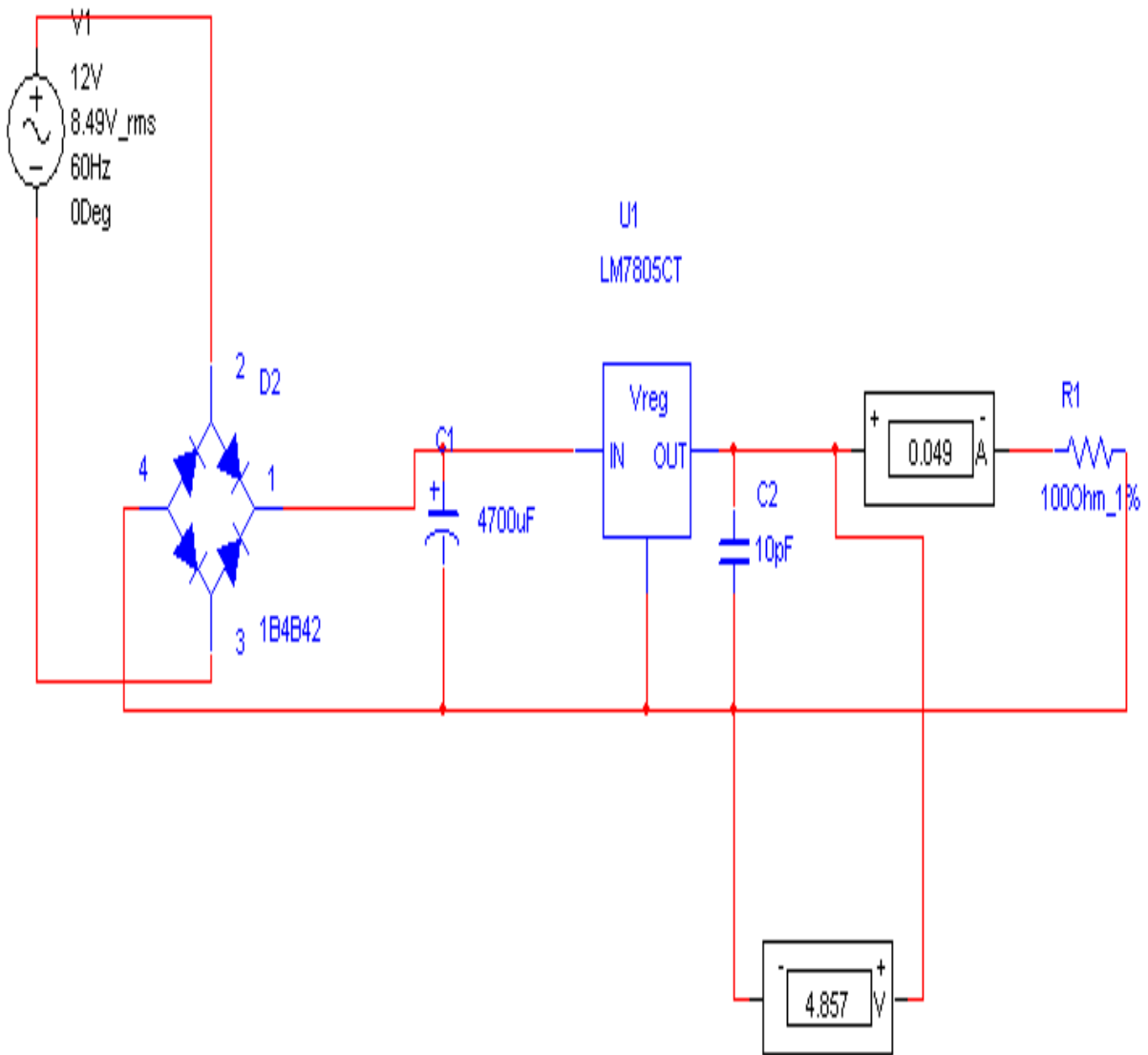

3.3 16 x 2 CHARACTER LCD



FEATURES

- 5 x 8 dots with cursor
- Built-in controller (KS 0066 or Equivalent)
- + 5V power supply (Also available for + 3V)
- 1/16 duty cycle
- B/L to be driven by pin 1, pin 2 or pin 15, pin 16 or A.K (LED)
- N.V. optional for + 3V power supply

PIN NUMBER SYMBOL FUNCTION

- . 1 Vss GND
- . 2 Vdd + 3V or + 5V
- . 3 Vo Contrast Adjustment
- . 4 RS H/L Register Select Signal
- . 5 R/W H/L Read/Write Signal
- . 6 E H → L Enable Signal
- . 7 DB0 H/L Data Bus Line
- . 8 DB1 H/L Data Bus Line

- 9 DB2 H/L Data Bus Line
- 10 DB3 H/L Data Bus Line
- 11 DB4 H/L Data Bus Line
- 12 DB5 H/L Data Bus Line
- 13 DB6 H/L Data Bus Line
- 14 DB7 H/L Data Bus Line
- 15 A/Vee + 4.2V for LED/Negative Voltage Output

Microcontroller – LCD Interfacing

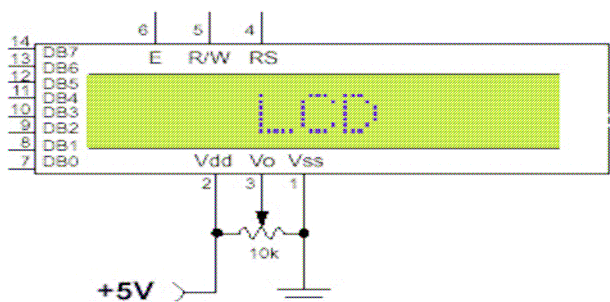

Above is the quite simple schematic. The LCD panel's *Enable* and *Register Select* is connected to the Control Port. The Control Port is an open collector / open drain output. Therefore by incorporating the two 10K external pull up resistors, the circuit is more portable for a wider range of computers, some of which may have no internal pull up resistors. I make no effort to place the Data bus into reverse direction. Therefore I had wire the *R/W* line of the LCD panel, into write mode. This will cause no bus conflicts on the data lines. As a result I cannot read back

the LCD's internal Busy Flag which tells us if the LCD has accepted and finished processing the last instruction [20]. This problem is overcome by inserting known delays into my program. The 10k Potentiometer controls the contrast of the LCD panel. Nothing fancy here.

I used a power supply of 5volt. The user may select whether the LCD is to operate with a 4-bit data bus or an 8-bit data bus. If a 4-bit data bus is used, the LCD will require a total of 7 data lines. If an 8-bit data bus is used, the LCD will require a total of 11 data lines [20]. LCD with 8-bit data bus is used for this design. The three control lines are **EN**, **RS**, and **RW**. EN line must be raised/lowered before/after each instruction sent to the LCD regardless of whether that instruction is read or write text or instruction. In short, I manipulate EN when communicating with the LCD.

3.4 LED

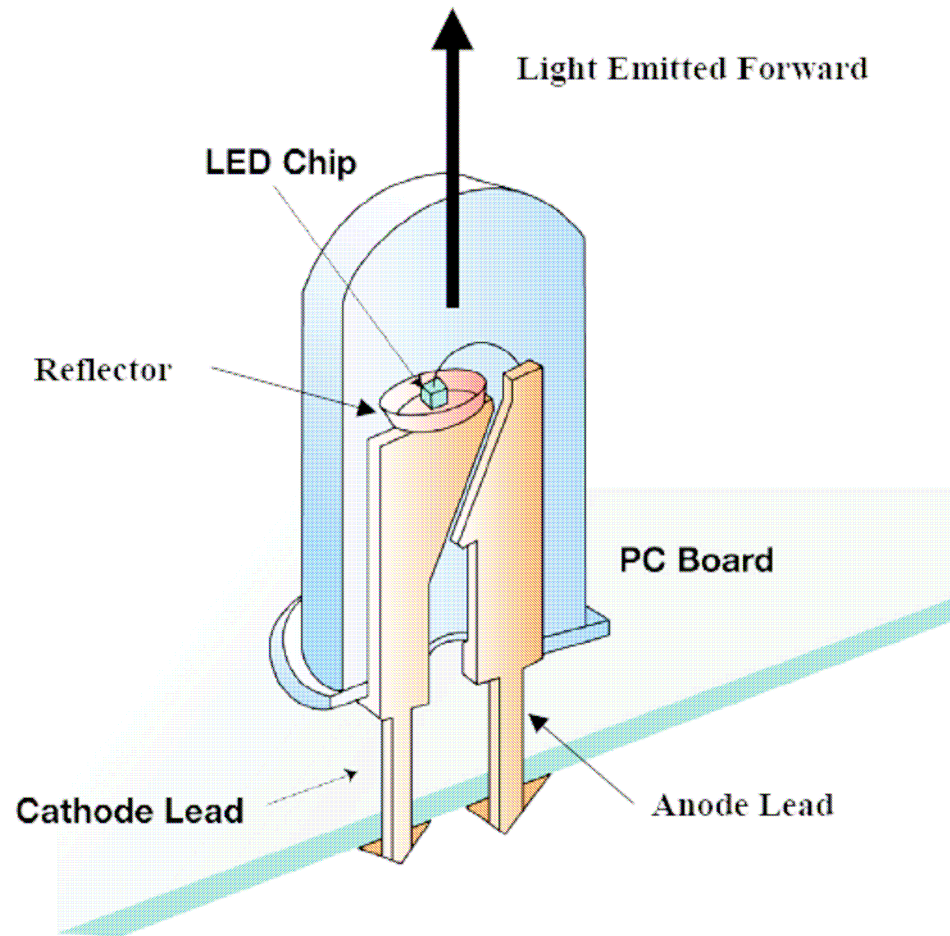

TYPICAL SPEC. OF HB LED

1 Watt LED Full intensity 350mA, Maximum current 500mA

2.8V Volt drop @ 350mA

3 Watt LED Full intensity 700mA, Maximum current 1A

4.3V Volt drop @ 700mA

5 Watt LED (multi-die package) Full intensity 700mA, Maximum current 1A

7.1V Volt drop @ 700mA

5 Watt LED (single-die) Full intensity 1.5A

CHARACTERISTICS OF LEDs

- Forward Voltage (VF) drop across LED Diodes are current driven!
- Wavelength variations Crystal and junction growth defects
- Brightness variations Crystal defects resulting formation of phonons and non-radiation energy transfer

- Temperature Junction temperature of the device affects each of the parameters above

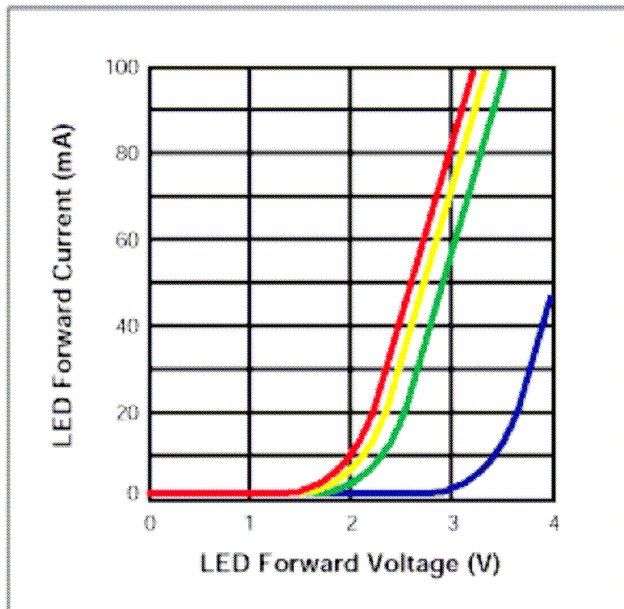

3.5 Resistors

The resistor's function is to reduce the flow of electric current. There are two classes of resistors; fixed resistors and the variable resistors. They are also classified according to the material from which they are made. The typical resistor is made of either carbon film or metal film. There are other types as well, but these are the most common. The resistance value of the resistor is not the only thing to consider when selecting a resistor for use in a circuit. The "tolerance" and the

electric power ratings of the resistor are also important. The tolerance of a resistor denotes how close it is to the actual rated resistance value. For example, a $\pm 5\%$ tolerance would indicate a resistor that is within $\pm 5\%$ of the specified resistance value.

Fixed Resistors

A fixed resistor is one in which the value of its resistance cannot change.

Carbon film resistors

This is the most general purpose, cheap resistor. Usually the tolerance of the resistance value is $\pm 5\%$. Power ratings of 1/8W, 1/4W and 1/2W are frequently used. Carbon film resistors have a disadvantage; they tend to be electrically noisy. Metal film resistors are recommended for use in analog circuits. However, I have never experienced any problems with this noise. The physical size of the different resistors is as follows.

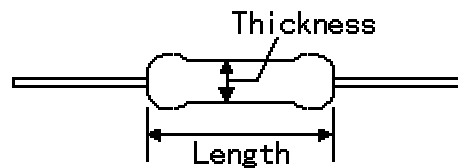

Rough size

| From the top of the photograph | Rating power | Thickness | Length |
|--------------------------------|--------------|-----------|--------|
| 1/8W | (W) | (mm) | (mm) |
| 1/4W | 1/8 | 2 | 3 |
| 1/2W | | | |

| | | |
|-----|---|---|
| 1/4 | 2 | 6 |
| 1/2 | 3 | 9 |

The physical size of the different resistors

Variable Resistors

There are two general ways in which variable resistors are used. One is the variable resistor which value is easily changed, like the volume adjustment of Radio. The other is semi-fixed resistor that is not meant to be adjusted by anyone but a technician. It is used to adjust the operating condition of the circuit by the technician. Semi-fixed resistors are used to compensate for the inaccuracies of the resistors, and to fine-tune a circuit. The rotation angle of the variable resistor is usually about 300 degrees. Some variable resistors must be turned many times to use the whole range of resistance they offer. This allows for very precise adjustments of their value.

These are called "Potentiometers" or "Trimmer Potentiometers."



<http://www.hobby-elec.org/>

Variable Resistors

In the photograph to the left, the variable resistor typically used for volume controls can be seen on the far right. Its value is very easy to adjust. The four resistors at the center of the photograph are the semi-fixed type. These ones are mounted on the printed circuit board. The two resistors on the left are the trimmer potentiometers.

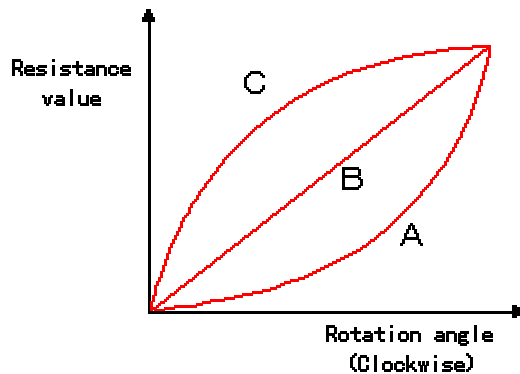

Resistance value Vs. Rotation Angle

There are three ways in which a variable resistor's value can change according to the rotation angle of its axis.

When type "A" rotates clockwise, at first, the resistance value changes slowly and then in the second half of its axis, it changes very quickly. The "A" type variable resistor is typically used for the volume control of a radio, for example. It is well suited to adjust a low sound subtly. It

suits the characteristics of the ear. The ear hears low sound changes well, but isn't as sensitive to small changes in loud sounds. A larger change is needed as the volume is increased. These "A" type variable resistors are sometimes called "audio taper" potentiometers.

As for type "B", the rotation of the axis and the change of the resistance value are directly related. The rate of change is the same, or linear, throughout the sweep of the axis. This type suits a resistance value adjustment in a circuit, a balance circuit and so on.

They are sometimes called "linear taper" potentiometers. Type "C" changes exactly the opposite way to type "A". In the early stages of the rotation of the axis, the resistance value changes rapidly, and in the second half, the change occurs more slowly. This type isn't too much used. It is a special use. As for the variable resistor, most are type "A" or type "B".

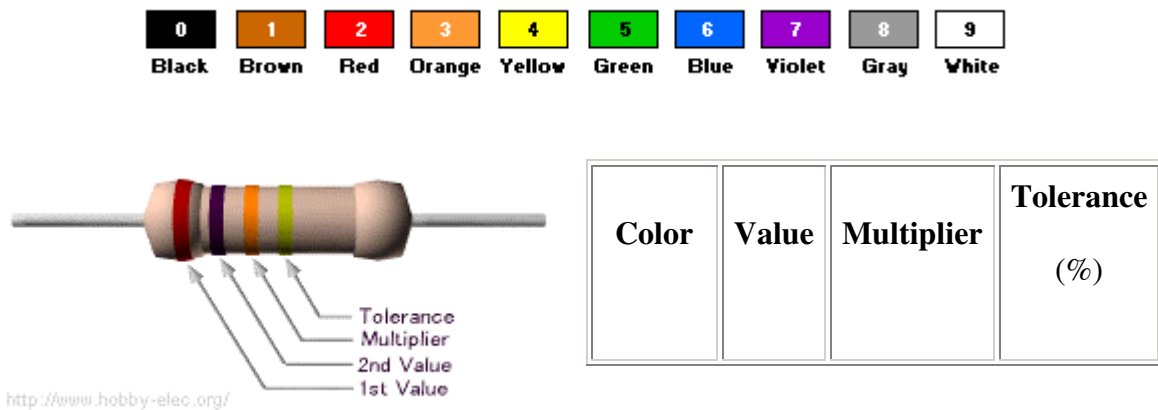

Example 1

(Brown=1),(Black=0),(Orange=3)

$$10 \times 10^3 = 10\text{k ohm}$$

Tolerance(Gold) = $\pm 5\%$

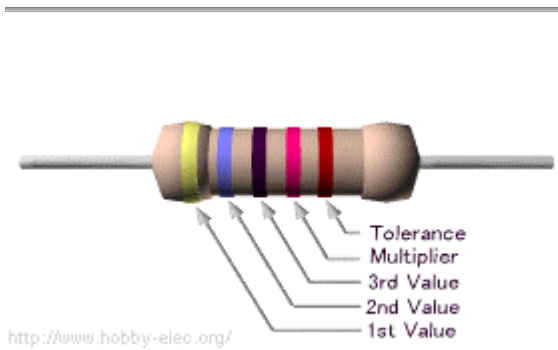

Example 2

(Yellow=4),(Violet=7),(Black=0),(Red=2)

$$470 \times 10^2 = 47\text{k ohm}$$

Tolerance(Brown) = $\pm 1\%$

| | | | |
|---------------|---|----|------------|
| Black | 0 | 0 | - |
| Brown | 1 | 1 | ± 1 |
| Red | 2 | 2 | ± 2 |
| Orange | 3 | 3 | ± 0.05 |
| Yellow | 4 | 4 | - |
| Green | 5 | 5 | ± 0.5 |
| Blue | 6 | 6 | ± 0.25 |
| Violet | 7 | 7 | ± 0.1 |
| Gray | 8 | 8 | - |
| White | 9 | 9 | - |
| Gold | - | -1 | ± 5 |
| Silver | - | -2 | ± 10 |
| None | - | - | ± 20 |

Resistor color code

3.6 Capacitors

The capacitor's function is to store electricity, or electrical energy. The capacitor also functions as a filter, passing alternating current (AC), and blocking direct current (DC). This symbol 'F' is used to indicate a capacitor in a circuit diagram. The capacitor is constructed with two electrode plates facing each other, but separated by an insulator. When DC voltage is applied to the capacitor, *an electric charge* is stored on each electrode. While the capacitor is charging up, current flows. The current will stop flowing when the capacitor has fully charged.

Types of Capacitor

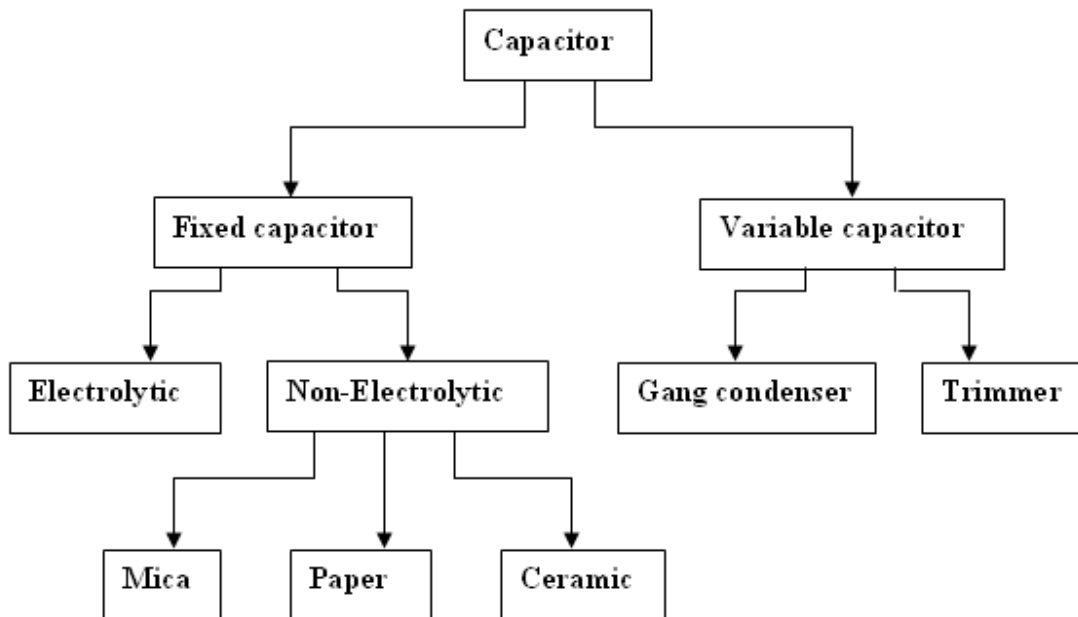

Types of Capacitor

Breakdown voltage

when using a capacitor, we must pay attention to the maximum voltage which can be used. This is the "breakdown voltage." The breakdown voltage depends on the kind of capacitor being used. We must be especially careful with electrolytic capacitors because the breakdown voltage is comparatively low. The breakdown voltage of electrolytic capacitors is displayed as Working Voltage. The breakdown voltage is the voltage that when exceeded will cause the dielectric (insulator) inside the capacitor to break down and conduct. When this happens, the failure can be catastrophic.

Electrolytic Capacitors (Electrochemical type capacitors)

Aluminum is used for the electrodes by using a thin oxidization membrane. Large values of capacitance can be obtained in comparison with the size of the capacitor, because the dielectric used is very thin. The most important characteristic of electrolytic capacitors is that they have polarity. They have a positive and a negative electrode. [Polarised] This means that it is very important which way round they are connected. If the capacitor is subjected to voltage exceeding its working voltage, or if it is connected with incorrect polarity, it may burst. It is extremely dangerous, because it can quite literally explode. Make absolutely no mistakes. Generally, in the circuit diagram, the positive side is indicated by a "+" (plus) symbol. Electrolytic capacitors range in value from about $1\mu\text{F}$ to thousands of μF . Mainly this type of capacitor is used as a ripple filter in a power supply circuit, or as a filter to bypass low frequency signals, etc. Because this type of capacitor is comparatively similar to the nature of a coil in

construction, it isn't possible to use for high-frequency circuits. (It is said that the frequency characteristic is bad.)

The photograph on the left is an example of the different values of electrolytic capacitors in which the capacitance and voltage differ.

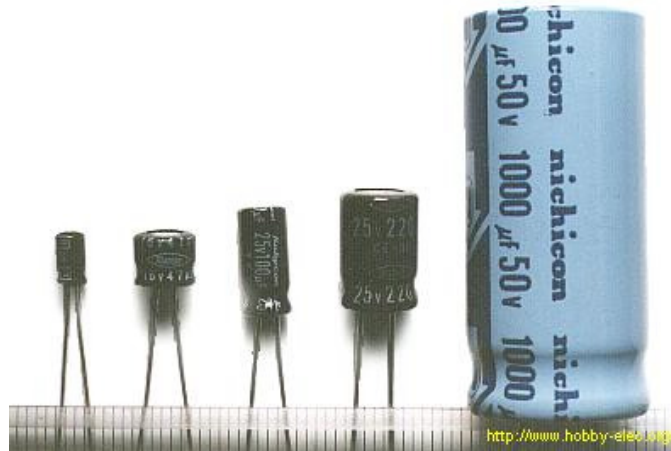

Electrolytic Capacitors

From the left to right:

1 μ F (50V) [diameter 5 mm, high 12 mm]

47 μ F (16V) [diameter 6 mm, high 5 mm]

100 μ F (25V) [diameter 5 mm, high 11 mm]

220 μ F (25V) [diameter 8 mm, high 12 mm]

1000 μ F (50V) [diameter 18 mm, high 40 mm]

The size of the capacitor sometimes depends on the manufacturer. So the sizes shown here on this page are just examples.

Ceramic Capacitors

Ceramic capacitors are constructed with materials such as titanium acid barium used as the dielectric. Internally, these capacitors are not constructed as a coil, so they can be used in high frequency applications. Typically, they are used in circuits which bypass high frequency signals to ground. These capacitors have the shape of a disk. Their capacitance is comparatively small. The capacitor on the left is a 100pF capacitor with a diameter of about 3 mm. The capacitor on the right side is printed with 103, so 10×10^3 pF becomes 0.01 μ F. The diameter of the disk is about 6 mm. Ceramic capacitors have no polarity. Ceramic capacitors should not be used for analog circuits, because they can distort the signal.



Ceramic Capacitors

Variable Capacitors

Variable capacitors are used for adjustment etc. of frequency mainly. On the left in the photograph is a "trimmer," which uses ceramic as the dielectric. Next to it on the right is one that uses polyester film for the dielectric. The pictured components are meant to be mounted on a printed circuit board.

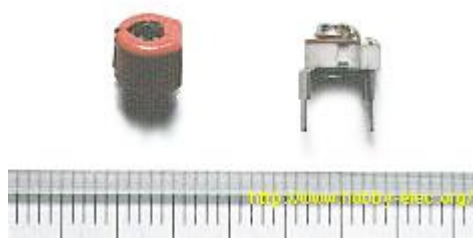

Variable Capacitors

When adjusting the value of a variable capacitor, it is advisable to be careful. One of the component's leads is connected to the adjustment screw of the capacitor. This means that the value of the capacitor can be affected by the capacitance of the screwdriver in your hand. It is better to use a special screwdriver to adjust these components.

CHAPTER FOUR

4.1 Serial Communication

4.1.1 Initializations

The baud rate of the modem was set to be 9600 bps using the HyperTerminal, The ECHO from the modem was turned off using the command ATE0 at the HyperTerminal. For serial transmission and reception to be possible both the DTE and DCE should have same operational baud rates. Hence to set the microcontroller at a baud rate of 9600bps, I set terminal count of Timer 1 at 0FFh (clock frequency = 1.8432). The TCON and SCON registers were set accordingly.

4.1.2 Serial transfer using TI and RI flags

After setting the baud rates of the two devices both the devices are now ready to transmit and receive data in form of characters. Transmission is done when TI flag is set and similarly data is known to be received when the Rx flag is set. The microcontroller then sends an AT command to the modem in form of string of characters serially just when the TI flag is set. After reception of a character in the SBUF register of the microcontroller (response of MODEM with the read message in its default format or ERROR message or OK message), the RI flag is set and the received character is moved into the physical memory of the microcontroller [22].

4.2 Programmer

When we have to learn about a new computer we have to familiarize about the machine capability we are using, and we can do it by studying the internal hardware design (devices architecture), and also to know about the size, number and the size of the registers.

A microcontroller is a single chip that contains the processor (the CPU), non-volatile memory for the program (ROM or flash), volatile memory for input and output (RAM), a clock and an I/O control unit. Also called a "computer on a chip," billions of microcontroller units (MCUs) are embedded each year in a myriad of products from toys to appliances to automobiles. For example, a single vehicle can use 70 or more microcontrollers. The following picture describes a general block diagram of microcontroller.

1. AVR Studio (Cross Compiler)

The AVR Studio IDE from Atmel combines project management, make facilities, source code editing, program debugging, and complete simulation in one

powerful environment. The AVR Studio development platform is easy-to-use and helping you quickly create embedded programs that work. The AVR Studio editor and debugger are integrated in a single application that provides a seamless embedded project development environment.

2. Embedded C (Programming Language)

We use C language to develop logic for the functioning.

4.2 Microcontroller (Atmega-8A)

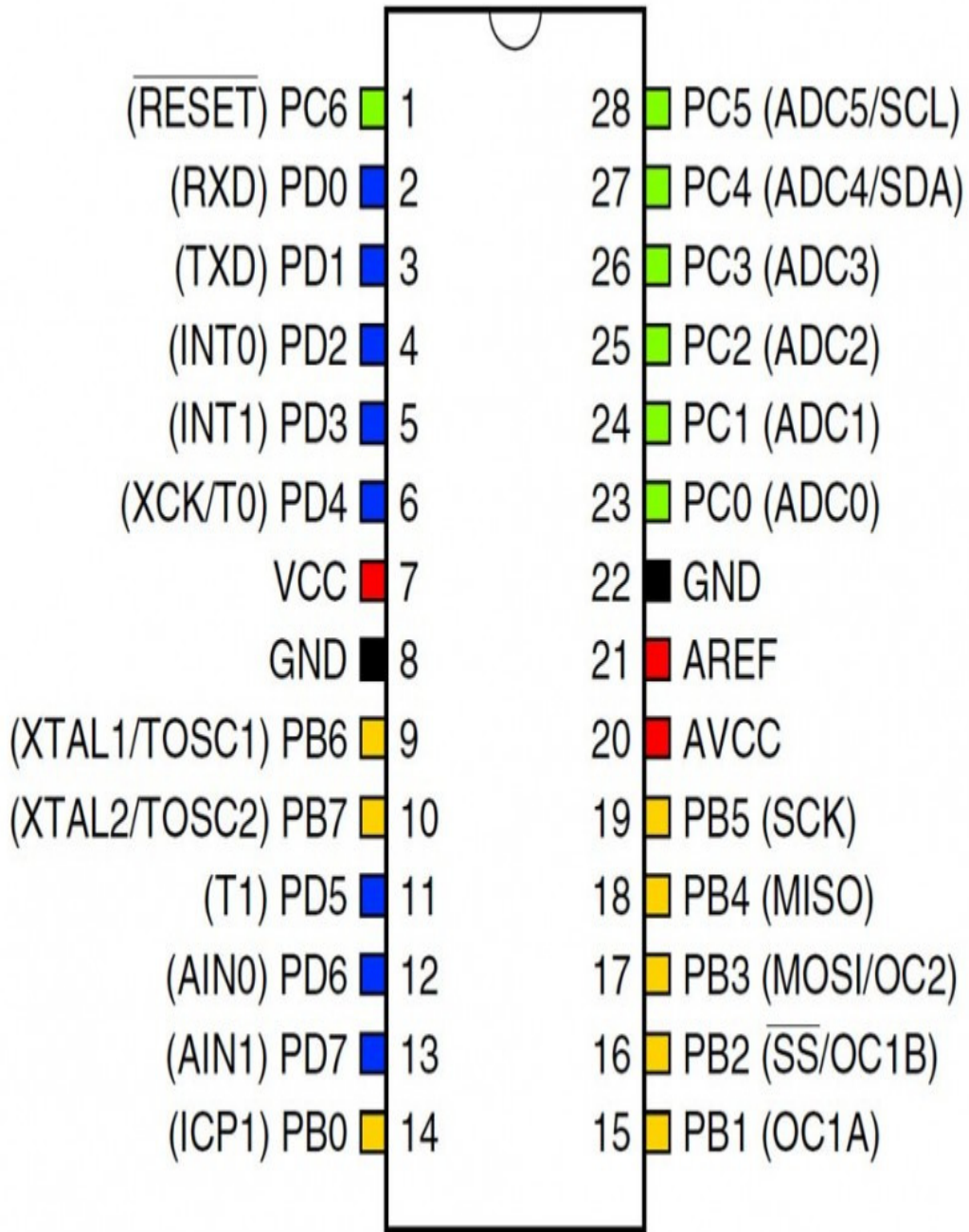

Features

- High-performance, Low-power Atmel®AVR® 8-bit Microcontroller
- Advanced RISC Architecture
 - 130 Powerful Instructions – Most Single-clock Cycle Execution
 - 32 x 8 General Purpose Working Registers
 - Fully Static Operation
 - Up to 16MIPS Throughput at 16MHz
 - On-chip 2-cycle Multiplier
- High Endurance Non-volatile Memory segments
 - 8KBytes of In-System Self-programmable Flash program memory
 - 512Bytes EEPROM
 - 1KByte Internal SRAM
 - Write/Erase Cycles: 10,000 Flash/100,000 EEPROM
 - Data retention: 20 years at 85°C/100 years at 25°C(1)
 - Optional Boot Code Section with Independent Lock Bits
- In-System Programming by On-chip Boot Program
- True Read-While-Write Operation

- Programming Lock for Software Security

- Atmel QTouch® library support

- Capacitive touch buttons, sliders and wheels

- Atmel QTouch and QMatrix acquisition

- Up to 64 sense channels

- Peripheral Features

- Two 8-bit Timer/Counters with Separate Prescaler, one Compare Mode

- One 16-bit Timer/Counter with Separate Prescaler, Compare Mode, and Capture Mode

- Real Time Counter with Separate Oscillator

- Three PWM Channels

- 8-channel ADC in TQFP and QFN/MLF package

- Eight Channels 10-bit Accuracy

- 6-channel ADC in PDIP package

- Six Channels 10-bit Accuracy

- Byte-oriented Two-wire Serial Interface

- Programmable Serial USART

- Master/Slave SPI Serial Interface

- Programmable Watchdog Timer with Separate On-chip Oscillator

- On-chip Analog Comparator

- Special Microcontroller Features
 - Power-on Reset and Programmable Brown-out Detection

 - Internal Calibrated RC Oscillator

 - External and Internal Interrupt Sources

 - Five Sleep Modes: Idle, ADC Noise Reduction, Power-save, Power-down, and Standby

- I/O and Packages
 - 23 Programmable I/O Lines

 - 28-lead PDIP, 32-lead TQFP, and 32-pad QFN/MLF

- Operating Voltages
 - 2.7 - 5.5V

 - 0 - 16MHz

- Power Consumption at 4MHz, 3V, 25°C
 - Active: 3.6mA

– Idle Mode: 1.0mA

4.3 Simulator

AVR Studio is an integrated development environment used to create software to be run on embedded systems (like a microcontroller). It allows for such software to be written either in assembly or C programming languages and for that software to be simulated on a computer before being loaded onto the microcontroller. The software used is c programming

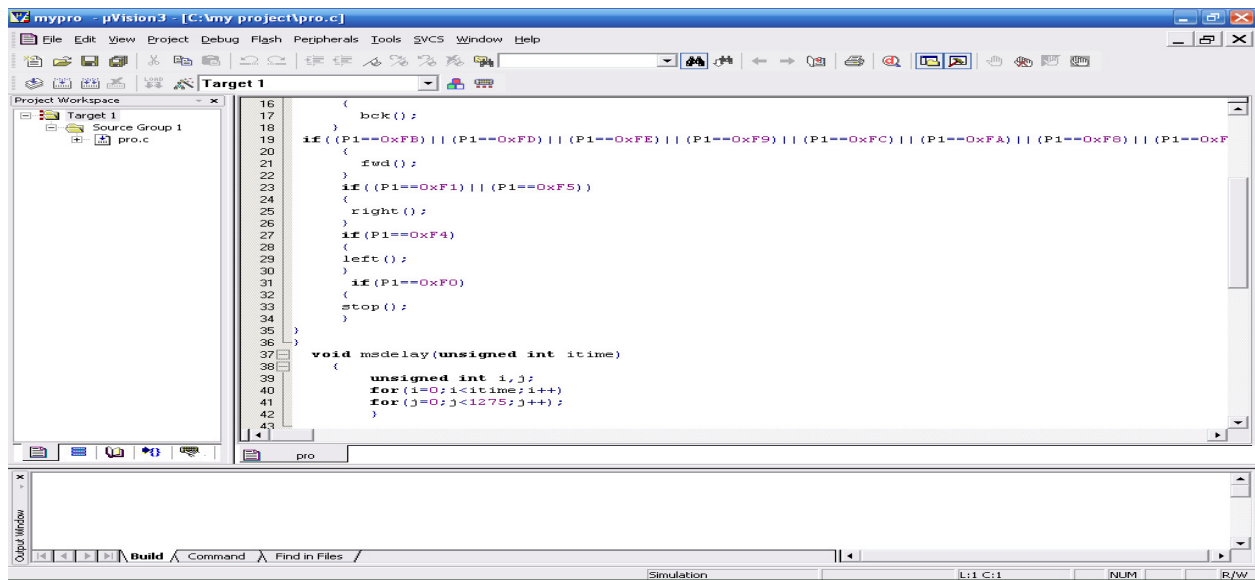

AVR Studio is an IDE (Integrated Development Environment) that helps write, compile, and debug embedded programs. It encapsulates the following components:

- A project manager.
- A make facility.
- Tool configuration.
- Editor.
- A powerful debugger.

To create project in AVR Studio:

1. Select Project - New Project.
2. Select a directory and enter the name of the project file.
3. Select Project –Select Device and select a device from Device Database.
4. Create source files to add to the project
5. Select Project - Targets, Groups, and Files. Add/Files, select Source Group1, and add the Source files to the project.
6. Select Project - Options and set the tool options. Note that when the target device is selected from the Device Database all-special options are set automatically. Default memory model settings are optimal for most applications.
7. Select Project - Rebuild all target files or Build target.

To create a new project, simply start micro vision and select “Project”=>”New Project” from the pull–down menus. In the file dialog that appears, a filename and directory was chosen for the project. It is recommended that a new directory be created for each project, as several files will be generated. Once the project has been named, the dialog shown in the

figure below will appear, prompting the user to select a target device. The chip being used is the “ATMEGA-8A,” which is listed under the heading “Atmel”.

Next, a file must be added to the project that will contain the project code. To do this, expand the “Target 1” heading, right-click on the “Source Group 1” folder, and select “Add files...” Create a new blank file (the file name should end in “.c”), select it, and click “Add.” The new file should now appear in the “Project Workspace” pane under the “Source Group 1” folder. Double-click on the newly created file to open it in the editor. To compile the program, first save all source files by clicking on the “Save All” button, and then click on the “Rebuild All Target Files” to compile the program as shown in the figure below. If any errors or warnings occur during compilation, they will be displayed in the output window at the bottom of the screen. All errors and warnings will reference the line and column number in which they occur along with a description of the problem so that they can be easily located.

CHAPTER FIVE

5.1 Conclusion

GSM technology is latest technology which is now in use in Industries as well as security and surveillance. We found its application in Home security, vehicle security etc.

In industries it used for notification system, security and other applications

5.2 Problem Encountered

- During soldering, many of the connection become short cktd. So we desolder the connection and did soldering again.
- A leg of the crystal oscillator was broken during mounting. So it has to be replaced.
- LED`s get damaged when we switched ON the supply so we replace it by the new one.
- TROUBLESHOOT
- Care should be taken while soldering. There should be no shorting of joints.
- Proper power supply should maintain.

5.3 Future Improvement

- Technology becomes our life easy .Using GSM technology we can make some powerful and innovative projects to serve our society and nation. We can use this technology in different projects:-
 1. Automatic Toll Tax System
 2. Automatic Car Parking System
 3. ATM Machine
 4. Railway Reservation

5.3 References:

1. “AVR and embedded system” by Mazidi and Mazidi

2. All datasheets from www.datasheetcatalog.com

3. About ATmega8A from www.atmel.com