

# **IOT BASED PATIENT MONITORING SYSTEM**

*Dissertation submitted in partial fulfillment of the requirements for the  
Degree of*

## **BACHELOR OF TECHNOLOGY IN ELECTRONICS AND COMMUNICATION ENGINEERING**

BY

**SAHAJ CHOPRA-151009  
ANUBHAV TOMAR-151060  
MANAN KASHMIRI-151086**

UNDER THE GUIDANCE OF  
**MR. MUNISH SOOD**



JAYPEE UNIVERSITY OF INFORMATION TECHNOLOGY, WAKNAGHAT  
May 2019

# TABLE OF CONTENTS

<b>TOPIC</b>	<b>Page number</b>
<b>DECLARATION BY SCHOLAR</b>	<b>iii</b>
<b>CERTIFICATE</b>	<b>iv</b>
<b>LIST OF FIGURES</b>	<b>v</b>
<b>ACKNOWLEDGEMENT</b>	<b>vi</b>
<b>ABSTRACT</b>	<b>1</b>
<b>CHAPTER 1</b>	<b>2</b>
<b>INTRODUCTION</b>	
<b>CHAPTER 2</b>	<b>5</b>
<b>COMPONENTS USED</b>	
<b>CHAPTER 3</b>	<b>19</b>
<b>LITERATURE SURVEY</b>	
<b>CHAPTER 4</b>	<b>25</b>
<b>METHODOLOGY</b>	
<b>CHAPTER 5</b>	<b>31</b>
<b>OBSERVATION AND RESULT</b>	
<b>CHAPTER 6</b>	<b>38</b>
<b>APPLICATION AND LIMITATION</b>	
<b>CHAPTER 7</b>	<b>41</b>
<b>CONCLUSION</b>	
<b>REFERENCES</b>	<b>43</b>

## **DECLARATION BY THE SCHOLAR**

I hereby declare that the work reported in the B-Tech thesis entitled **“IOT BASED PATIENT MONITORING SYSTEM”** submitted at **Jaypee University of Information Technology, Solan, India**, is an authentic record of my work carried out under the supervision of **Mr. Munish Sood**. I have not submitted this work elsewhere for any other degree or diploma.

Sahaj Chopra

Anubhav Tomar

Manan Kashmiri

Department of Electronics and communication Engineering  
Jaypee University of Information Technology, Waknaghat, India  
Date: 20 May,2019.



JAYPEE UNIVERSITY OF  
INFORMATION  
TECHNOLOGY

Established by H.P. State Legislative vide Act No  
.14 of 2002) P.O. Wagnaghat, Teh. Kandaghat, Distt.  
Solan - 173234 (H.P.) INDIA Website: [www.juit.ac.in](http://www.juit.ac.in)  
Phone No: (91)01792-257999  
Fax : +91-01792-245362

**CERTIFICATE**

This is to certify that the work reported in the B.Tech project report  
entitled “**IOT**

**BASED PATIENT HEALTH MONITORING SYSTEM** “which is being  
submitted by **Sahaj Chopra(151009), Anubhav Tomar(151060), Manan Kashmiri  
(151086)** in fulfillment for the award of Bachelor of Technology in Electronics and  
Communication Engineering by the Jaypee University of Information Technology, is  
the record of candidate’s own work carried out by him/her under my supervision.  
This work is original and has not been submitted partially or fully anywhere else  
for any other degree or diploma.

-----  
Mr.Munish Sood

Assistant Professor (Grade-II)  
Department of Electronics & Communication Engineering  
Jaypee University of Information Technology, Wagnaghat.

विद्या तत्व ज्योतिसमः

# LIST OF FIGURES

<b>Figure No.</b>	<b>Caption</b>	<b>Page</b>
1.1	Smart care	2
2.1	Ardino uno	4
2.2	DHT11	6
2.3	Internal structure of DHT11	7
2.4	Connections of DHT11	8
2.5	Characteristics of DHT11	9
2.6	Pulse rate sensor	10
2.7	Circuit diagram of pulse rate sensor	12
2.8	Pulse rate sensor connection	13
2.9	Wi-fi module	14
2.10	ESP8266EX block diagram	14
2.11	Resistor	16
2.12	Bread board and jumping wires	16
3.1	E- health care steps	20
4.1	Circuit implementation	22
4.2	Block diagram	22
4.3	Thinkspeak platform	24
4.4	Channel formation	24
4.5	Connection to cloud	25
5.1	Full implantation	27
5.2	Readings	27

## ACKNOWLEDGEMENT

We take this opportunity to express our gratitude to our supervisor **Mr. Munish Sood**, for his insightful advice, motivating suggestions, invaluable guidance, help and support in successful completion of this project and also for his constant encouragement and advice throughout our Bachelors program.

The in-house facilities provided by the department throughout the Bachelors program are also equally acknowledgeable. We would like to convey our thanks to the teaching and non-teaching staff of the Department of Electronics and Communication Engineering for their invaluable help and support.

Sahaj Chopra  
151009

Anubhav Tomar  
151060

Manan Kashmiri  
151086

## **ABSTRACT**

This project introduces the structure and usage of an IoT based patient observing framework, utilizing different sensors and Arduino UNO as the MCU (Master Control Unit). The framework can be utilized to constantly screen the wellbeing parameters of a patient. The body temperature and heartbeat rate can be measured from anyplace on the globe utilizing IoT (Internet Of Things). IOT is executed, utilizing an ESP Wi-Fi module, which enables the data to be transmitted flawlessly over the web. The gadget is compact and can be fueled by a 5 V DC source by PC.

### Keywords

Arduino Uno , DHT 11 temperature sensor , Pulse rate sensor , patient health monitoring system , ESP8266 WI-FI module.

# CHAPTER1

## INTRODUCTION

Today there is an expansion in the number of individuals with a infections; this is because of different dangerous factors, for example, dietary patterns, physical exercises and some more. From the details of WHO, around 5.1 million individuals kick the bucket from throat cancer growth, from the utilization of tobacco, 3.2 million experiencing cholesterol and 6.0 million experiencing hypertension . It is assessed that there will be increment in the quantity of passing's in the coming future.

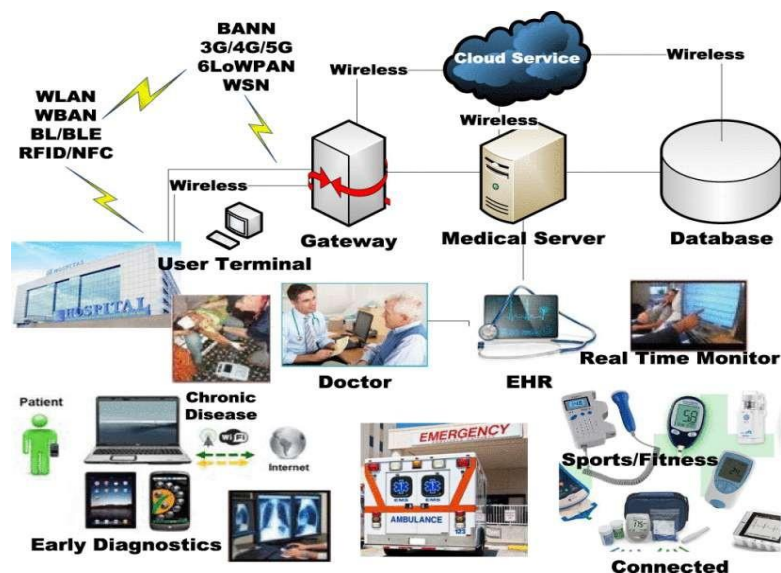

Figure:1.1 SMART CARE

These maladies are not analyzed so effectively and there treatment differs from ailment to sickness. In the event that these maladies are not analyzed on schedule, at that point the life of the individual can be in hazard. A few illnesses, for example, diabetes, Blood weight and a lot more have same indications.

Today there is a development in the quantity of people with a diseases; this is a direct result of various hazardous components, for instance, dietary examples, physical activities and some more.



The general population with such issues set aside a long effort to know the truth of these ailments. So there must be an appropriate checking to such an extent that the individual having such infection can be analyzed and can be given by the reasonable treatment. Because of the sensors used to check beat, temperature sensor are not incredibly correct and its size is generous and eats up a huge amount of power. From decades there is a customary method for estimating temperature and heartbeat rate however at this point in view of the progression in the innovation we can think that its in all respects effectively.

The reports of the patient can be inspected effectively on regular schedule and specialist suggestions can be send effectively. So in light of the utilization of web of things persistent well being can be observed. There must be a suitable checking to such a degree, that the individual having such disorder can be assessed and can be given by the sensible treatment. From decades there is a standard technique for assessing temperature and heartbeat rate regardless now in setting on the advancement in the improvement we can feel that its in all regards sensibly. The possibility of Iot is most recent and is characterised as the association of all gadgets through the system, kept up from web and enable us to interface with the general population.

The Internet of Things has a number difficulties that are as yet present. As in the equipment layer, the intention is to permit the interconnection of physical articles utilizing sensors and related advancements.

The difficulties related with this layer are identified with scaling down, while today there are gadgets with capacity, preparing, interior parts ought to be littler and to improve proficiency. On account of the sensors used to gauge pulse, temperature sensors are not extremely exact and its size is substantial and devours a ton of intensity.

It is crucial to access the benefits that accompany propels in revolution, for example, the IoT, as they have transformed into a significant mechanism for transfer of the information from any stage, allowing full correspondence P2P and machine – to - machine (M2M), to improve social insurance of individuals.

The overall public with such issues put aside a long exertion to know reality of these afflictions. So there must be a fitting checking to such a degree, that the individual having such disease can be broke down and can be given by the sensible treatment. Due to the sensors used to check beat, temperature sensors are not unimaginably right and its size is liberal and gobbles up a colossal measure of intensity. From decades there is a standard technique for assessing temperature and heartbeat rate anyway now in perspective on the movement in the advancement we can believe that its in all regards successfully

# CHAPTER 2

## COMPONENTS USED

### 2.1 Arduino Uno:

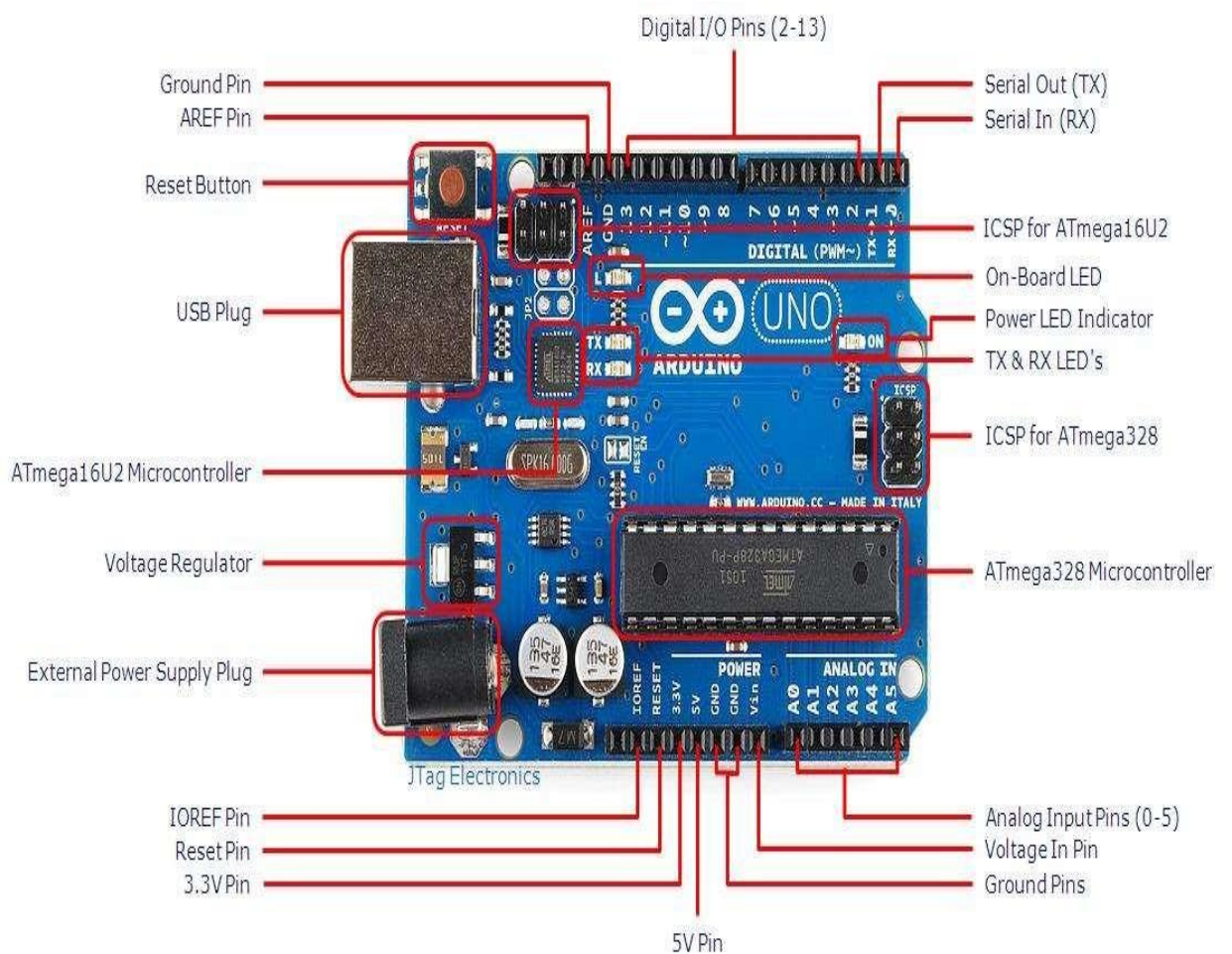

**FIGURE:2.1 ARDUINO**

Arduino Uno is a microcontroller; it is an open-source devices platform subject to AVR microcontroller Atmega328.

Arduino microcontroller can be used in a wide extent of endeavors from robots and warming pad, hand heating spread to astrology machines, and even dice-hurling gauntlet, the Arduino can be used as the cerebrums behind essentially any equipment adventure.

It contains inside it, all of the functionalities required to operate the controller efficiently and it can be directly connected with PC using USB interface that is used to transfer the code to the controller with the help of IDE which stands for Integrated Development Environment, unequivocally designed to program the Arduino board. IDE is comparatively impeccable with Windows, MAC or Linux Systems. The Arduino chip contains the vast majority of the functionalities required to operate the controller and it can be directly connected with PC through universal bus interface that is utilized to transfer and run the code to the controller with the help of IDE , unequivocally designed to program Arduino. Improvement can be effectively done in the vast majority of the stages.

The Arduino Uno is altered using Arduino Software which uses C and C++ for programming making it humble to learn. The AVR microcontroller goes with worked in boot loader that exchanges the program on the board. Arduino is a very powerful microcontroller and can be used in very automation tasks.

Arduino can be controlled either through USB, battery and DC connector. It continues running on 5V and can withstand an apex voltage of 20 Volts.

Arduino Uno boards have 14 Digital pins, 6 Analog sticks, and are programmable with the Arduino IDE by methods for a USB connect. The straightforward pins named 0 to 5 are used to examine the commitment from sensors like Temperature sensor, moist sensor, Accelerometer.

The data banner is changed over to modernized gathering for data taking care of. These pins as a result of high check measure just voltage. The information flag is

changed over to modernized assembling for information dealing with. These pins because of high check measure just voltage.

Reset Switch: It is turned to low to reset the microcontroller. The banner will be sent to microcontroller to run the program from the scratch.

## 2.2. Temperature Sensor:

### Temperature Sensor IC

The DHT11 detects water vapor by measuring the electrical resistance between two electrodes. The humidity sensing component is a moisture holding substrate with electrodes applied to the surface. When water vapor is absorbed by the substrate, ions are released by the substrate which increases the conductivity between the electrodes. The change in resistance between the two electrodes is proportional to the relative humidity. Higher relative humidity decreases the resistance between the electrodes, while lower relative humidity increases the resistance between the electrodes.

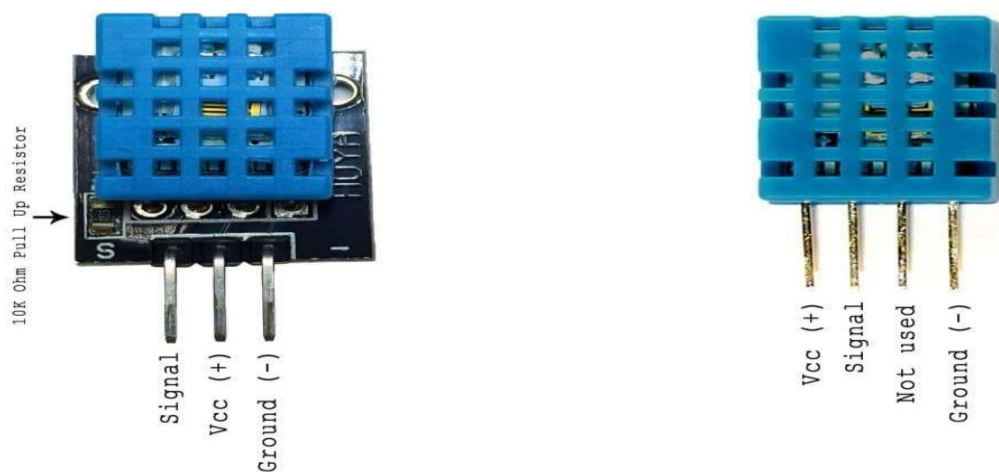

FIGURE:2.2 DHT11

### **DHT11 working principle:**

Let's see how these sensors actually work. They consist of a humidity sensing component, a NTC temperature sensor (or thermistor) and an IC on the back side of the sensor.

For measuring humidity they use the humidity sensing component which has two electrodes with moisture holding substrate between them. So as the humidity changes, the conductivity of the substrate changes or the resistance between these electrodes changes. This change in resistance is measured and processed by the IC which makes it ready to be read by a microcontroller.

On the other hand, for measuring temperature these sensors use a NTC temperature sensor or a thermistor.

A thermistor is actually a variable resistor that changes its resistance with change of the temperature. These sensors are made by sintering of semiconductive materials such as ceramics or polymers in order to provide larger changes in the resistance with just small changes in temperature. The term "NTC" means "Negative Temperature Coefficient", which means that the resistance decreases with increase of the temperature.

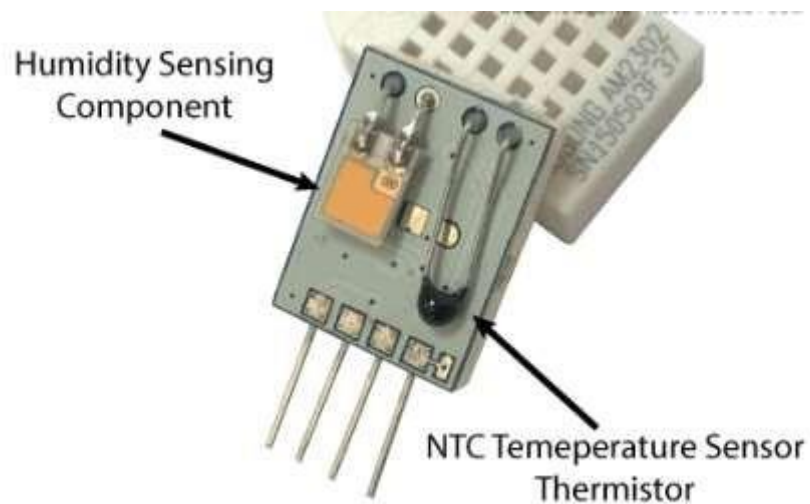

**FIGURE:2.3** INTERNAL STRUCTURE OF DHT11

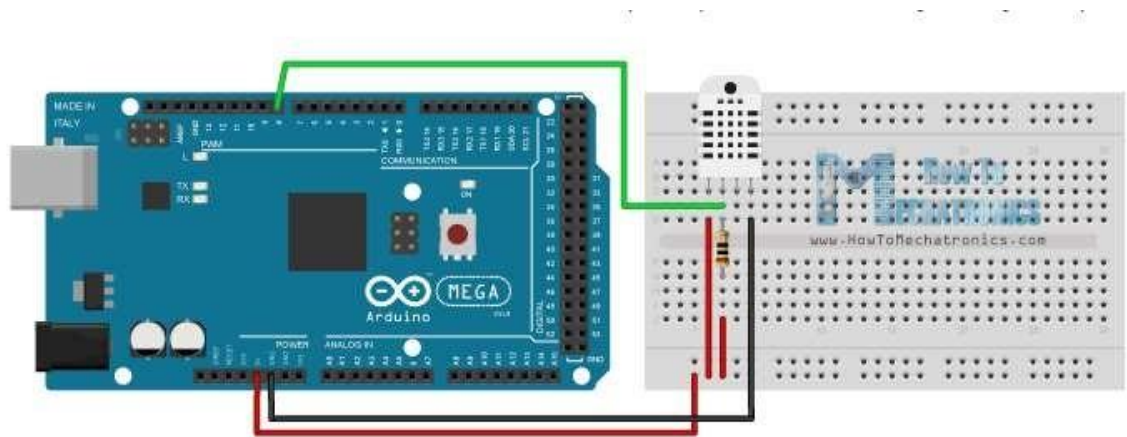

**FIGURE:2.4 CONNECTION OF DHT11**

**Specification of our temperature sensor are:**

- The working Voltage is from 3.5 V ~ 5.5 V
- The Functioning current is 0.3 mA
- Output is in the form of Serial data
- The temperature range is 0 °C ~ 50 °C
- It displays output within accuracy of  $\pm 1$  °C



## Electrical Characteristics

---

Parameter	Min.	Typical	Max.	Unit
Working voltage	3	5	5.5	VDC
Working current (VCC=5V, T=25°C)	0.5	-	2.5	mA
Sampling interval	1	-	-	s

### Humidity

Parameter	Min.	Typical	Max.	Unit
Accuracy (25°C)	-	±4	-	%RH
Accuracy (0-50°C)	-	-	±5	%RH
Measurement range (25°C)	20	-	95	%RH
Response time: 1/e (63%) 25°C, 1m/s air	6	10	15	s

### Temperature

Parameter	Min.	Typical	Max.	Unit
Accuracy	±1	-	±2	°C
Measurement range	0	-	50	°C
Response time 1/e (63%)	6	-	30	s

**FIGURE:2.5** CHARACTERISTICS OF DHT11

### 2.3 Pulse Rate Sensor:

Observing pulse is significant for , patients as it tells us the condition of the person. There exist many methods to compute pulse and the most accurate in today's market is through Electrocardiography

In any case, using the Heartbeat Sensor as in our project is most simple and handy way to measure heartbeat.

Heartbeat Sensors are accessible in Wrist Watches as in case of Smart Watches, nowadays even in the Smart Phones, and so on. The heartbeat is estimated in thumps every moment or bpm, which shows the occasions the heart is contracting or extending in a moment.



FIGURE:2.6 PULSE RATE SENSOR

**Principle of Heartbeat Sensor:**

The technique of measuring heartbeat is implemented in pulse rate sensor to measure the pulse of patient. In this technique, the light is passed in patients body (usually the finger) using the LED which is mostly red in color. The moving blood reflects the led as the pulse contracts and pumps the blood. The optical sensor present in the device records the light reflected by the blood, which is then used to estimate the blood flow eventually the pulse in the body.

**Working of Heart beat sensor:**

The basic heartbeat sensor consists of a light emitting diode and a detector like a light detecting resistor or a photodiode. The heart beat pulses causes a variation in the flow of blood to different regions of the body. When a tissue is illuminated with the light source, i.e. light emitted by the led, it either reflects (a finger tissue) or transmits the light. Some of the light is absorbed by the blood and the transmitted or the reflected light is received by the light detector. The amount of light absorbed depends on the blood volume in that tissue. The detector output is in form of electrical signal and is proportional to the heart beat rate.

This signal is actually a DC signal relating to the tissues and the blood volume and the AC component synchronous with the heart beat and caused by pulsatile changes in arterial blood volume is superimposed on the DC signal. Thus the major requirement is to isolate that AC component as it is of prime importance.

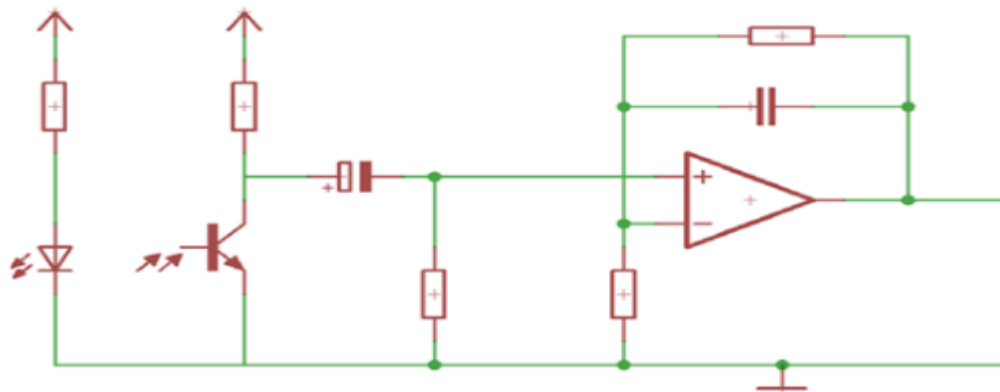

**FIGURE:2.7** CIRCUIT DIAGRAM OF PULSE RATE SENSOR

To achieve the task of getting the AC signal, the output from the detector is first filtered using a 2 stage HP-LP circuit and is then converted to digital pulses using a comparator circuit or using simple ADC. The digital pulses are given to a microcontroller for calculating the heart beat rate, given by the formula-

$$\text{BPM(Beats per minute)} = 60 * f$$

Where f is the pulse frequency



**FIGURE:2.8** PULSE RATE SENSOR CONNECTION

## **2.4 ESP8266:**

ESP8266 is the microcontroller made by Espressif Systems. This microcontroller can perform WIFI related activities subsequently it is commonly used as a WIFI module.

ESP8266 is available with requested set of firmware; it will in general be trapped to an Arduino device and work totally as Wi-Fi.



**FIGURE: 2.9** WIFI MODULE

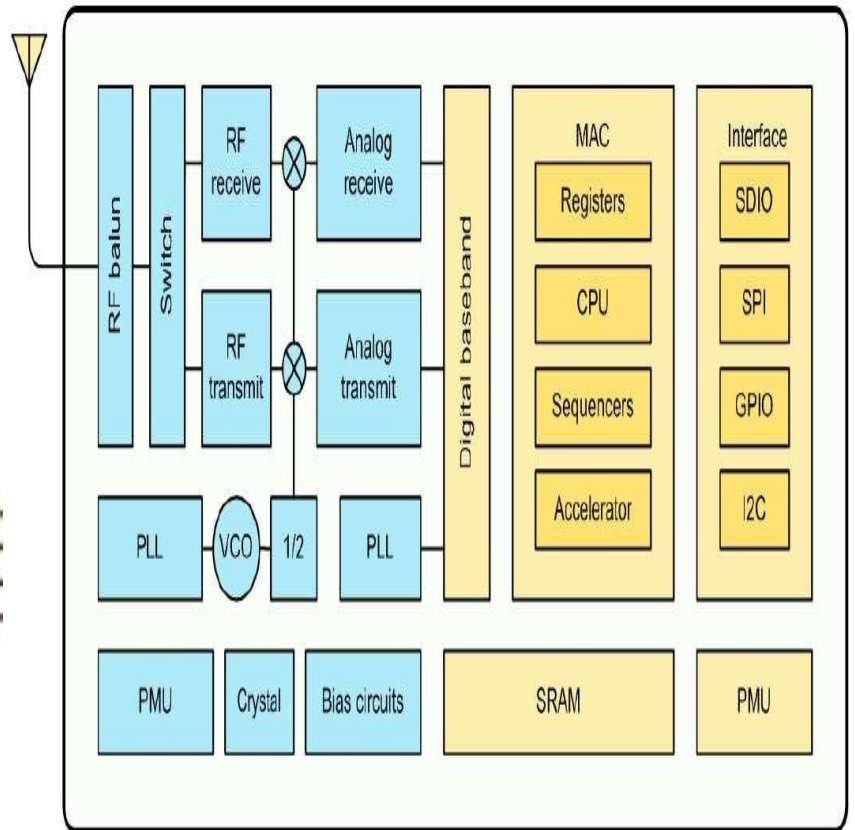

**FIGURE:2.10**  
ESP8266EX BLOCK DIAGRAM

**Various pins in wi-fi module:**

- Reset pin
- Ch\_pd
- General purpose input/ output pin 0 (GPIO 0)
- General purpose input/ output pin 2 (GPIO 2)
- Power voltage (Vcc)
- Receiving pin(Rx)
- Transmitting pin (Tx)
- Ground pin (Gnd)

Vcc and ground are powered up pins . Rx and Tx are used for communication purpose.

Using ESP8266 we can get a total independent Wi-Fi connection : it is then utilized to get the Wi-Fi related applications in a proper manner.

From the outside glimmer ESP8266 boots up its applications. We can do it for the execution of the kind of the application which we are using. It offers an aggregate sorting of Wi-Fi game plan.

It might be used for the various applications depending on the nature of the system which we are using.

From outside nature it boost up according to the application.

To improve the execution of the system we have fused store as an inbuilt function in it.

In this Wi-Fi module there are 8 pins which are used in such a way so as to achieve the application properly.

There may be some error coming in the circuit because of the wires or the breadboard short circuit in between.

There are 2 GPIO pins in the Wi-Fi module which is used as a general-purpose pin.

ESP8266 is compact in size and easy to use , there is only a need to configure the module with respect to the nature of the project.

It is mostly for the development of Internet of Things (IoT).

## 2.6 BREADBOARD AND JUMPING WIRES:

Breadboards are used to make the connections neatly for any type of project. Jumping wires are used to make the connection between the sensor and the arduino or any kind of device which we are using.

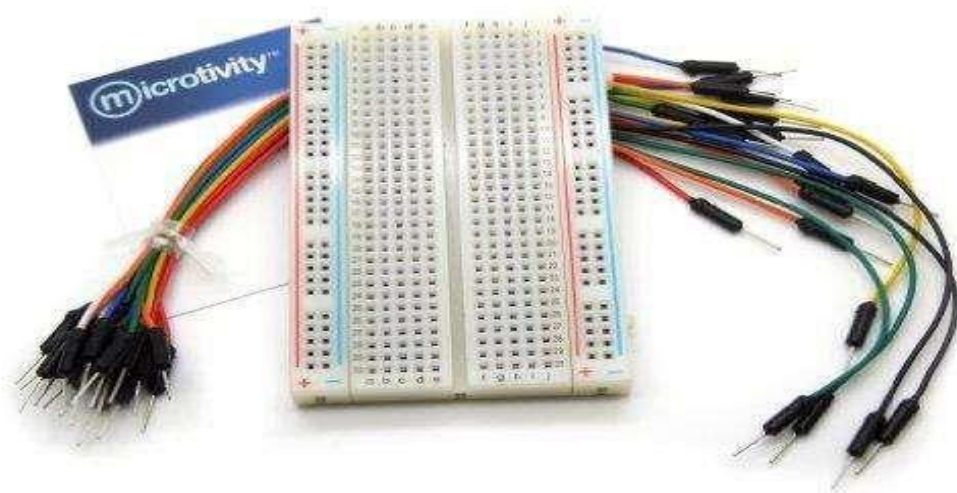

**FIGURE:2.12** BREADBOARD AND JUMPING WIRES



## **CHAPTER 3**

### **LITERATURE SURVEY**

#### **SMART HEALTH CARE SYSTEM USING INTERNET OF THINGS**

Prosperity is a central need. It is a human perfect to vitalize extraordinary restorative thought. In current scenario, India faces various restorative issues because of uncommon resources. This article gives a review of finding restorative issues using the latest development, Internet and things. This Using this procedure, physical parameters of the patient will be evaluated logically. The sensors assemble the patient's body parameters and trade this information to Arduino Uno, which by then trades this information to the cloud using a WLAN module.

Our country faces several therapeutic issues due to extraordinary assets. This article gives an audit of discovering therapeutic issues utilizing the most recent advancement, Internet and things. This Using this methodology, physical parameters of the patient will be assessed consistently. The sensors amass the patient's body parameters and exchange this data to Arduino Uno, which by then exchanges this data to the hosted server utilizing the wlan. On the off chance that the data is sporadic, the patient gets a notice that parental figures can get by methods for mail.

With the assistance of two or three higher learning tallies, races will be made and individuals will without a doubt get to the data as necessities be. The patient will have an accommodating history, along these lines giving top notch medicinal idea to all and giving a deficiency free and without patient correspondence.

The person suffering from the diseases will have a supportive history, along these lines giving top notch therapeutic idea to all and giving an inadequacy free and without patient correspondence.

This learning is secured in a MySQL database server that administers information and offers get to. The customer will examine this data with the help of the Man Mechanical application.

Mysql works on some commands known as queries. These, queries are used to fetch or add the data to mysql server

Example of commands in sql server are :

Heart Beat	Temperature
60	98
70	99
80	100

So server will use a command like :

Select \* from table;

This command will fetch whole of the results present.

So whole table will be fetched and result will be displayed in tabular form.

Which will be presented on your phone, tablet, or sensitive PC?

In case the information is sporadic, the person can be examined far away. With the help of a couple of higher learning counts, predictions will be made and people will doubtlessly get to the information as requirements be. The patient will have a helpful history, thusly giving first rate remedial thought to all and giving an insufficiency free and without patient correspondence.

**In Mobile Telemedicine System for Home Care and Patient Monitoring:**

paper portable communication is utilized to actualize the telemedicine framework. Through this progression any individual can be checked utilizing Rs232 interface. This is excellent framework which is very quick and we can depend on this framework. So it is one of the significant use of telemedicine. Additionally the staggering expense including in heading off to the specialist physically and completing ones examination

is all around exorbitant. There is a transportation issue which is likewise associated with going from the home to the clinic

## **HEALTH CARE SYSTEM**

The shrewd city is troublesome, numerous specialists and universal organizations have characterized their application and distributed computing at a more elevated amount.

- Provide a 2-way cloud correspondence framework format. Here, constant wellbeing records record precisely what data the sensor has distinguished with the goal that my SQL database server is utilized.
  
- The remote observing framework is combination of three sections:
  - i. Data security
  - ii. The cloud platform
  - iii. Health history portal

### **InDesign and Development of remote health Care Monitoring**

This design is based of WSN i.e. wireless sensor network and smart health care devices. It is very important to have a dedicated network between the patient whom we have to monitor, doctor and the care taker that tells the condition of the health of patient.

Various sensors are used to monitor the patient health. Environmental sensors are the name given to these sensors. Sensors are joined to the gadget and the user at the end. There is no need to visit the patient directly for the doctor and care taker instead, they can see the protective report of the patient uploaded in the server.

It is one of the best techniques used by the doctor because the doctor and caretaker has not to visit the patient directly.

So it is convenient for patient as well as doctor.

On the off chance that the data is sporadic, the patient can be examined far away integrating ease into the monitoring process. With the help of a couple of higher learning counts, predictions will be made and people will doubtlessly get to the information as requirements be. The patient will have a helpful history, thusly giving first rate remedial thought to all and giving an insufficiency free and without patient correspondence.



**FIGURE:3.1** E-HEALTHCARE STEPS

## CHAPTER 4

### METHODOLOGY

#### 4.1 HOW TO START IT OFF?

To start with, connect the Wi-Fi module with the controller i.e. in our case Arduino. ESP8266X works with 3V and in the event that you give 5V of Arduino, it won't work legitimately and you ought to experience the ill effects of damage. Associate the VCC just as CH\_PD to 3V stick of controller. The Receiver stick of the ESP8266 operates in 3V and cannot interface with Arduino in the wake of associating it to Arduino. Hence, we should construct a conceivable partition such that 5V can be changed over to 3V. This we will be finished by associating three offbeat resistances, to be done in circuit. Interface the Transmitter stick of the Wi-Fi module stick 9 from controller and furthermore the Receiver stick from the module to the stick 10 of the Arduino through the resistance.

The WIFI module gives access to WIFI or system. It requires little to no effort and make you exceptionally amazing. It will speak with the system and have fundamental gadgets in the IOT stage.

After that, associate the beat sensor with the Arduino. Associations the pulse sensor component is basic. The pulse sensor has three pins. Interface the 5V and furthermore the GND stick of the beat sensor to get the reading.

At that point associate the light emitting diode to the 13 pin of the Arduino. It isn't important to interface the resistor in light of the fact that Arduino contains the implicit resistor in the thirteen stick.

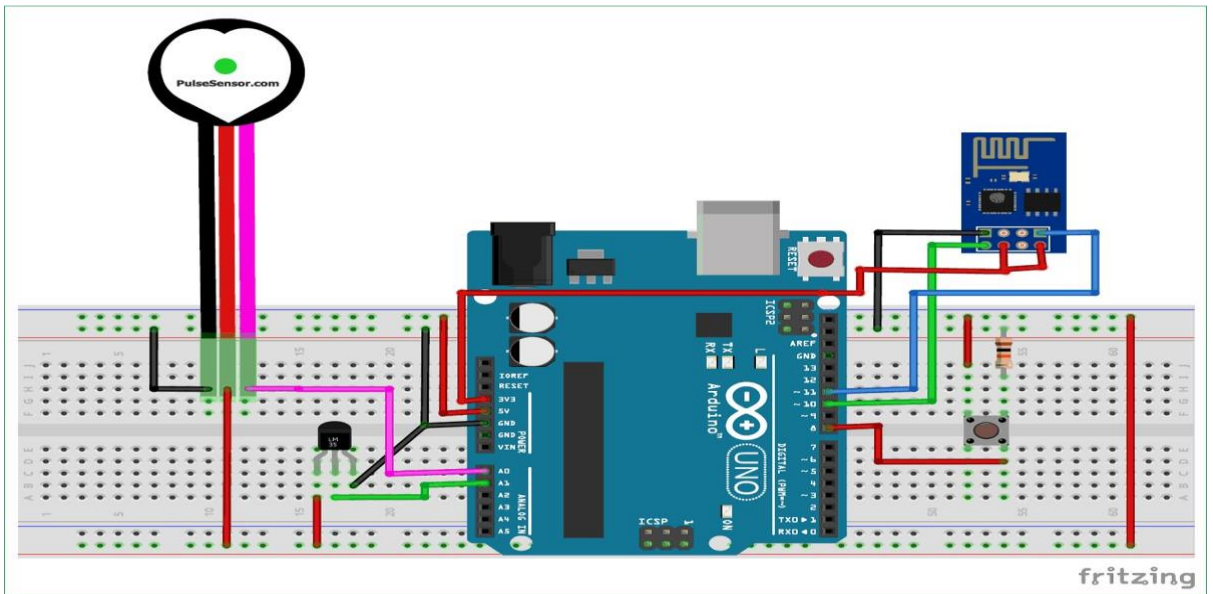

**FIGURE:4.1** CIRCUIT IMPLEMENTATION

Block Diagram of IOT based health monitoring project:

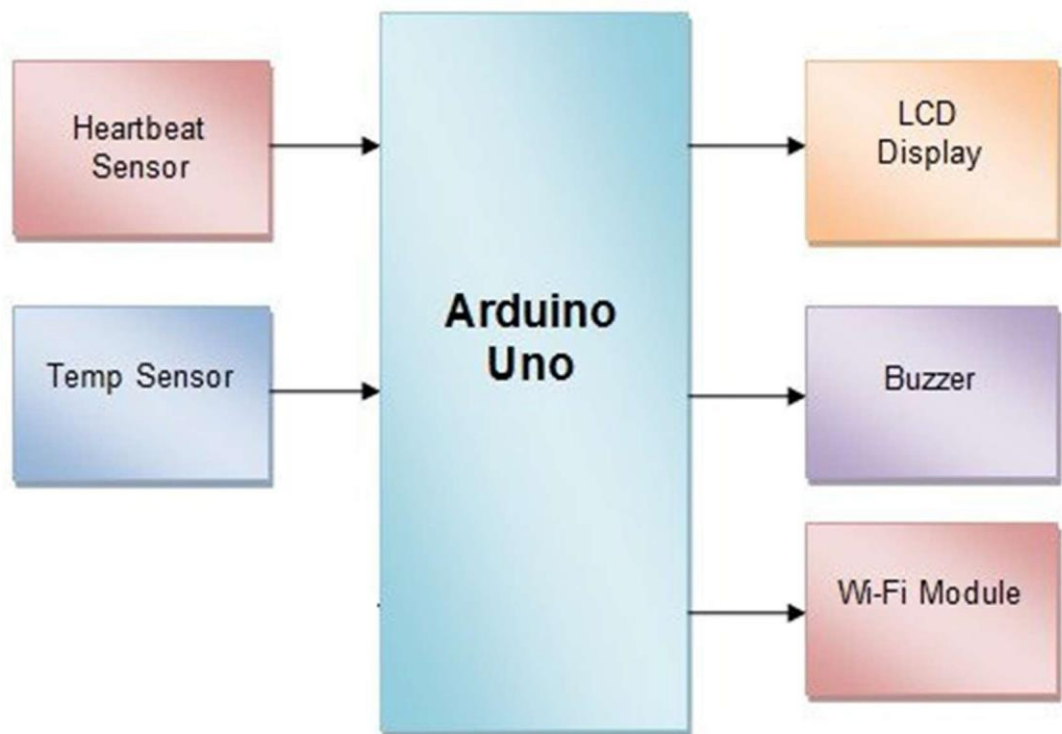

**FIGURE:4.2** BLOCK DIAGRAM



## **4.2 THINGSPEAK TOOL:**

ThingSpeak is an Internet Of Things (IoT) that enables you to gather and store sensor information in the

cloud and create Internet applications things. The ThingSpeak <sup>TM</sup> IoT stage gives applications that enable you to break down and imagine your information in MATLAB® and after that deal with information. Sensor information can be sent to ThingSpeak from Arduino®, Raspberry Pi <sup>TM</sup>, BeagleBone Black and different gadgets.

## **4.3 THINGSPEAK SETUP:**

ThingSpeak gives an excellent device to Internet-based tasks. Utilizing ThingSpeak, we can screen our information and control our online framework utilizing the channels and website pages given by ThingSpeak. ThingSpeak "gathers" sensor information, "separating and picturing" information and "activities" by animating the response.

## **4.4 STEPS TO SETUP THINGSPEAK:**

1. Create an account on think speak log on, and click on start:

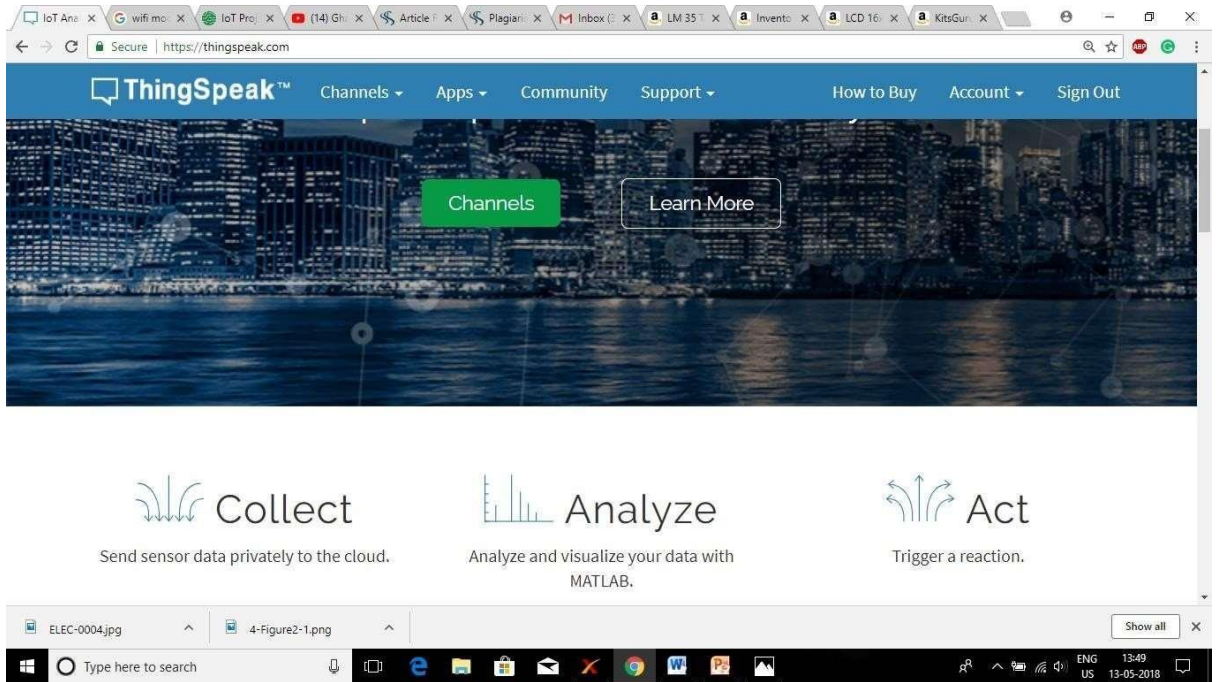

**FIGURE:4.3**THINGSPEAK PLATFORM

2.Once done go to channels, and create new channel:

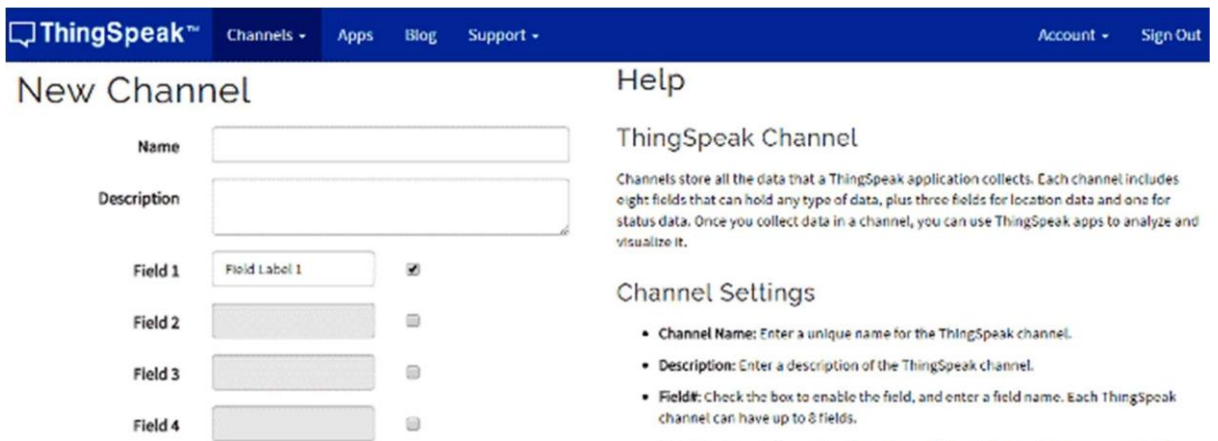

**FIGURE:4.4** CHANNEL FORMATION

3. Then API write key from the API section. This requires code. Check onto full icon at the end:

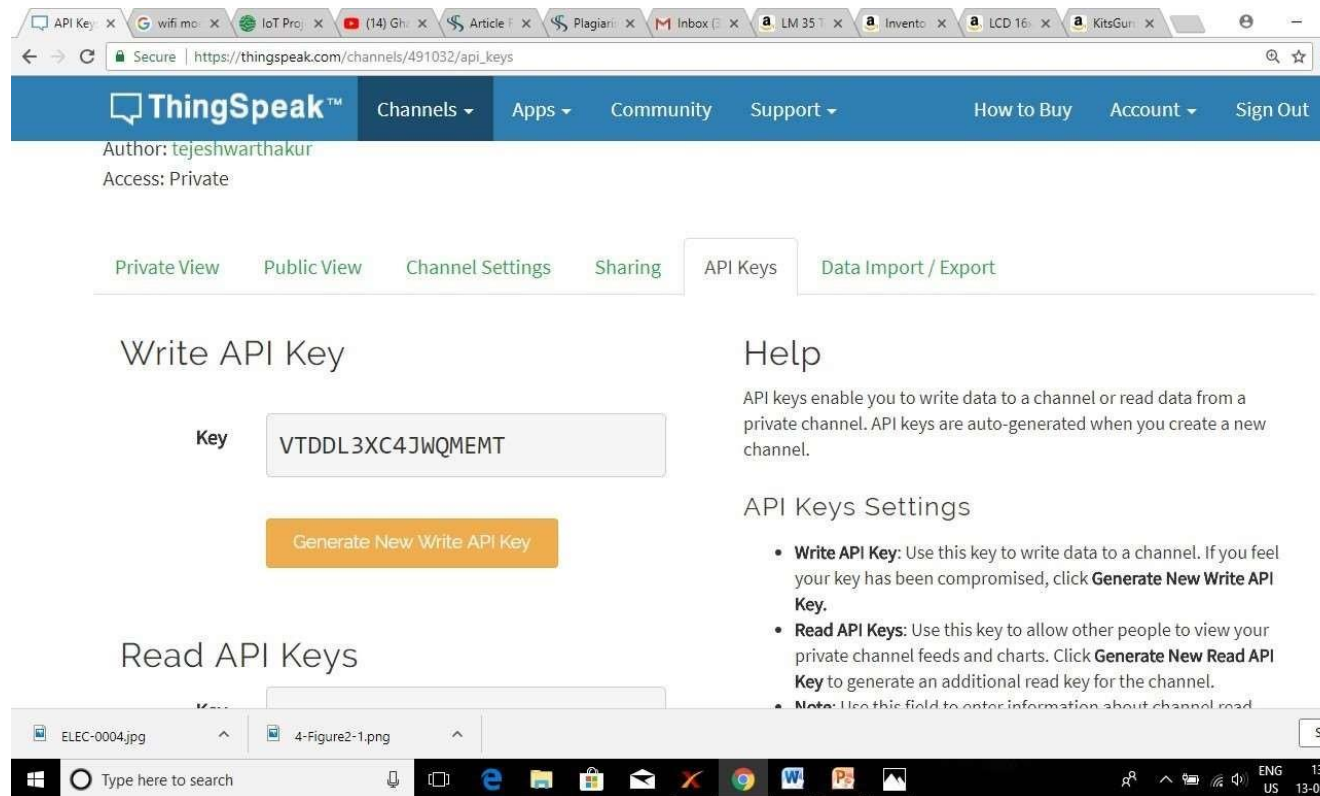

**FIGURE:4.5** CONNECTION TO CLOUD

#### **4.4 WORKING EXPLANATION:**

To begin with, we need to associate the heart rate sensor to anyone part where the pulse is essentially identified as a finger, see the video below. Arduino can change over this assorted variety to the every moment rate (BPM). The light-transmitting diode associated with stick 13 flashes as per the pulse.

ESP8266 can speak with Arduino and can send data to ThingSpeak. ESP8266 can interface a system of switches that can basically give in the code and can send sensor data through the Internet.

This data is shown in ThingSpeak in an outline layout that likewise demonstrates past readings and can be gotten to from anyplace on the web.

# CHAPTER 5

## OBSERVATION AND RESULTS

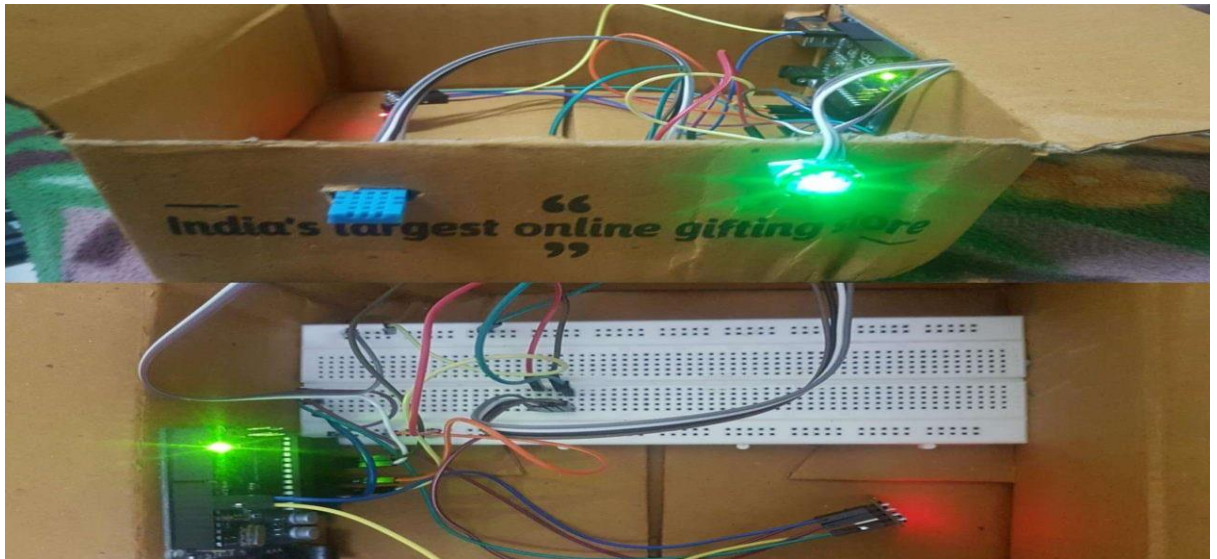

FIGURE:5.1 FULL IMPLEMENTATION

```
COM7
98.90
57
AT+CIPSTART="TCP","184.106.153.149",80
AT+CIPSEND=58
GET /update?key=PD6MREFBUGQWW6EX&field1=57.0&field2=98.9
98.90
46
AT+CIPSTART="TCP","184.106.153.149",80
AT+CIPSEND=58
AT+CIPCLOSE
98.90
55
AT+CIPSTART="TCP","184.106.153.149",80
AT+CIPSEND=58
GET /update?key=PD6MREFBUGQWW6EX&field1=55.0&field2=98.9
98.90
AT+CIPSTART="TCP","184.106.153.149",80
AT+CIPSEND=58
GET /update?key=PD6MREFBUGQWW6EX&field1= 0.0&field2=98.9
98.80
AT+CIPSTART="TCP","184.106.153.149",80
AT+CIPSEND=58
GET /update?key=PD6MREFBUGQWW6EX&field1= 0.0&field2=98.8
98.90
AT+CIPSTART="TCP","184.106.153.149",80
AT+CIPSEND=58
```

FIGURE:5.2 READINGS

```
yt | Arduino 1.8.9
File Edit Sketch Tools Help
yt
#define USE_ARDUINO_INTERRUPTS true
#define DEBUG true
#define SSID "s7" // "SSID-WiFiname"
#define PASS "12345678" // "password"
#define IP "184.106.153.149" // thingspeak.com ip

#include <SoftwareSerial.h>
#include "Timer.h"
#include <PulseSensorPlayground.h> // Includes the PulseSensorPlayground Library.
Timer t;
PulseSensorPlayground pulseSensor;

String msg = "GET /update?key=PD6MREFBUGQWW6EX";
SoftwareSerial esp8266(10,11);

//Variables
const int PulseWire = A0; // PulseSensor PURPLE WIRE connected to ANALOG PIN 0
const int LED13 = 13; // The on-board Arduino LED, close to PIN 13.
int Threshold = 550; //for heart rate sensor
float myTemp;
int myBPM;
String BPM;
String temp;
int error;
int panic;
int raw_myTemp;
float Voltage;
```

First, we include all the libraries. We are using software serial to communicate with esp8266.

Make instance for timer, SoftwareSerial and pulse sensor to use in our code.

Set-up low-level interrupts for most accurate BPM match and enable DEBUG to show ongoing commands on serial monitor.

Set your WiFiname , password and IP of thingspeak.com

```
yt | Arduino 1.8.9
File Edit Sketch Tools Help
yt
float tempC;
void setup()
{
  Serial.begin(9600);
  esp8266.begin(115200);
  pulseSensor.analogInput(PulseWire);
  pulseSensor.blinkOnPulse(LED13); //auto-magically blink Arduino's LED with heartbeat.
  pulseSensor.setThreshold(Threshold);

  // Double-check the "pulseSensor" object was created and "began" seeing a signal.
  if (pulseSensor.begin()) {
    Serial.println("We created a pulseSensor Object !"); //This prints one time at Arduino power-up,
  }
  Serial.println("AT");
  esp8266.println("AT");

  delay(3000);

  if(esp8266.find("OK"))
  {
    connectWiFi();
  }
  t.every(5000, getReadings);
  t.every(5000, updateInfo);
}
```

Declare String to update information on ThingSpeak channel. You will need API key for this, which can be found from your ThingSpeak channel-> API key . Copy Write API key and paste here.

In setup function, set the baud rate for serial communication between Arduino serial monitor and esp8266. Start the ESP communication by giving AT command to it and connect it by calling connectWiFi(); function. After that we will initialize Timers by calling t.every(time\_interval, do\_this); which will take the readings of the sensors and update on the channel after every time\_interval you defined.

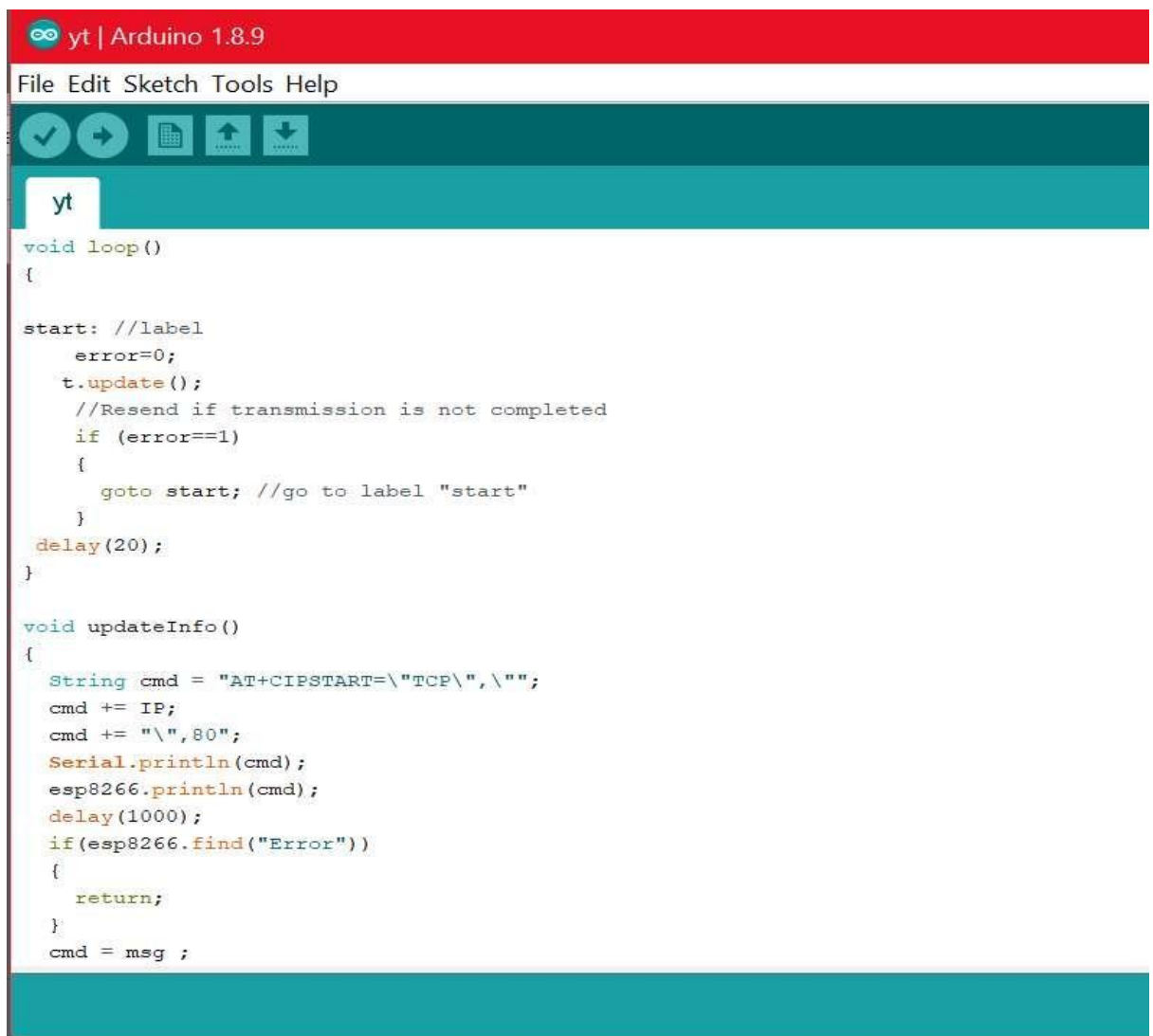

```
yt | Arduino 1.8.9
File Edit Sketch Tools Help
yt
void loop()
{
  start: //label
  error=0;
  t.update();
  //Resend if transmission is not completed
  if (error==1)
  {
    goto start; //go to label "start"
  }
  delay(20);
}

void updateInfo()
{
  String cmd = "AT+CIPSTART=\"TCP\", \"";
  cmd += IP;
  cmd += "\",80";
  Serial.println(cmd);
  esp8266.println(cmd);
  delay(1000);
  if(esp8266.find("Error"))
  {
    return;
  }
  cmd = msg ;
}
```

We have to make functions for connectWiFi(), panic\_button(), update\_info() and getReadings ().

Make function for connectWiFi() which will return True or False depending upon Wi-Fi connected or not.

Make getReadings(); function to take pulse sensor and LM35 readings and convert them to string using dtostrf();function



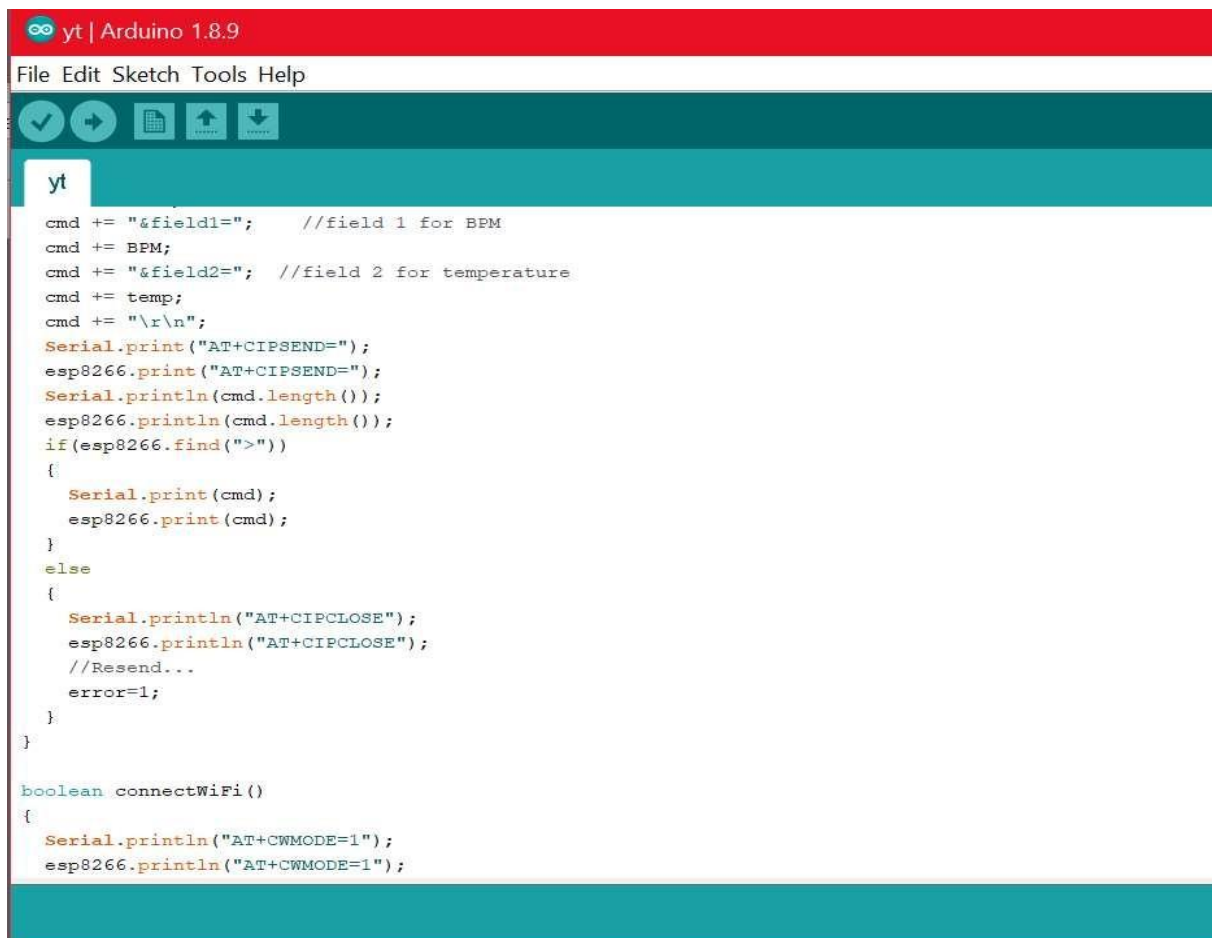

```
yt | Arduino 1.8.9
File Edit Sketch Tools Help
yt
cmd += "&field1="; //field 1 for BPM
cmd += BPM;
cmd += "&field2="; //field 2 for temperature
cmd += temp;
cmd += "\r\n";
Serial.print("AT+CIPSEND=");
esp8266.print("AT+CIPSEND=");
Serial.println(cmd.length());
esp8266.println(cmd.length());
if(esp8266.find(">"))
{
    Serial.print(cmd);
    esp8266.print(cmd);
}
else
{
    Serial.println("AT+CIPCLOSE");
    esp8266.println("AT+CIPCLOSE");
    //Resend...
    error=1;
}
}

boolean connectWiFi()
{
    Serial.println("AT+CWMODE=1");
    esp8266.println("AT+CWMODE=1");
}
```

Define char array for BPM and temp and convert float value of these sensors to String using `dtostrf()`.

Make function for updating sensor information on the ThingSpeak channel.

"AT+CIPSTART="TCP", AT Command will establish TCP command over port 80

Attach the readings with the GET URL using "&field1="; for pulse readings and "&field2="; for temperature readings. Send this information using "AT+CIPSEND=" command.

```
yt | Arduino 1.8.9
File Edit Sketch Tools Help
yt
delay(2000);
String cmd="AT+CWJAP=\"";
cmd+=SSID;
cmd+="\",";
cmd+=PASS;
cmd+="\"";
Serial.println(cmd);
esp8266.println(cmd);
delay(5000);
if(esp8266.find("OK"))
{
return true;
}
else
{
return false;
}
}

void getReadings(){
raw_myTemp = analogRead(A1);
Voltage = (raw_myTemp ); // 5000 to get millivots.
tempC = Voltage * 0.1;
myTemp = (tempC -3.4); // conver to F
Serial.println(myTemp);
int myBPM = pulseSensor.getBeatsPerMinute(); // Calls function on our pulseSensor object that returns BPM as an "int".
// "myBPM" hold this BPM value now.
if (pulseSensor.sawStartOfBeat()) { // Constantly test to see if "a beat happened".
Serial.println(myBPM); // Print the value inside of myBPM.
}

delay(2);
```

```
delay(2); |
char buffer1[10];
char buffer2[10];
BPM = dtostrf(myBPM, 4, 1, buffer1);
temp = dtostrf(myTemp, 4, 1, buffer2);
}
```

Attach this information to "&field3=".

## Channel Stats

Created: [a day ago](#)

Entries: 21

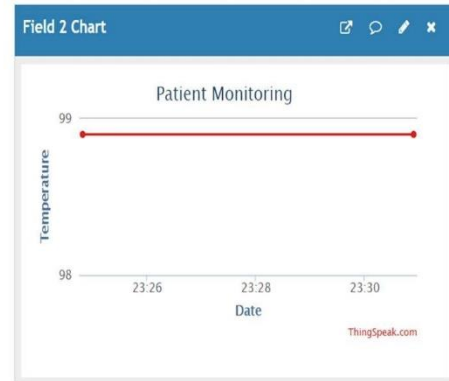
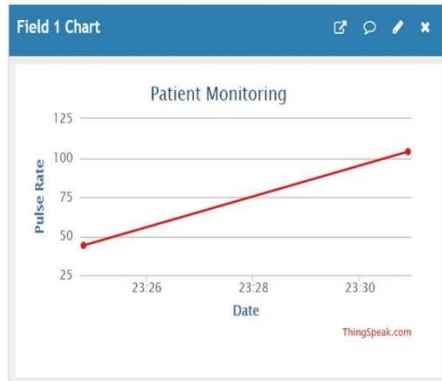

For creating the channel fill up the name and the description as per the choice of the individual.

Now fill “pulse Rate “, “Temperature” in the field 1 and field 2.

Now make a tick to the check box for the field name corresponding to different channels. Also tick right for making it public in the form and then set the channel properly and save it.

Now there is a creation of new channel with different field in between.

## CHAPTER-6

### 6.1 Advantage of this project:

1. IOT Monitoring system displays perfectly the parameters over the internet as well as on the display which can be examined by a specialist easily. Therefore with this iot based system we can have the sorted parameters over a well organized set of display, such as pie charts and graphs. Doctor or the specialist can easily go through the patients reports over the system from a far away place and can easily get the background as well as the present scenario of the patient to provide proper treatment
2. No need to stay and wait in long que to get your regular checkup.
3. Now u can just sit back and relax at home all reports are directly and safely sent to the doctor for the regular check.
4. Patients detailed reports are all kept safe over the cloud. Rather than a printed or a hand written report these are more easily accessible and readable over the use of internet. Also the informations and detailed reports are mobile and can be transmitted over a local memory device and can be taken along any where to get an access all over the world at any particular time .

## **6.2 Applications of this project:**

- I. IOT Medicare is the most demanding field in the healthcare field. This is basically for the older citizens. And also for each and every old citizen living alone or living with someone. The project is unarguably very help full as can monitoring is easy to be done and can be done by an individual who is alone at home or far away from relatives
- II. Disable people can easily use the project as it has a small size also easy to use. This is also for people who find hard to take time out for their regular checkups and find it hard to visit a specialist

### **6.3 Limitations:**

- In this framework, due to less physical stability of the temperature sensor , circuit may mess up.
- The latency and disturbances in WI-FI network, can cause the data to be delayed.
- In instance of power failure, the setup will be not work along these lines giving no readings. Be that as it may, this can be settled by interfacing extra dc battery.
- The pulse sensor, because of varieties in skin tone, may give interruptions in the readings.

### **6.4 Further Development:**

- The Oxygen stream sensor, weight sensor can be integrated with, according to the party's requirements .
- Fingerprint sensor can be integrated by clinics to protect the security of their patients, so just the approved relatives and specialists could access patient's private data.
- Therefore idea of savvy medicinal services shall be an indispensable piece of a perfect city architecture. Going to a specialist for a normal routine checkup can be done in few seconds and can sort out their issues regarding their health online via email reports and video conferencing

## **CHAPTER 7**

### **CONCLUSIONS**

We used cloud computing mechanism to store information, this data can be stored safely over the time and can be accessed at any moment of time. Cloud processing is additionally helpful to keep update of patient. Specialists and doctors can easily look into the patient reports at the time of emergency and can take appropriate steps accordingly. Hence giving proper guidance at proper time to prevent crisis. The concerned person can deal with patient without their actual physical presence the system automatically creates the diagram of body changes and reports to the doctor about the recent change of events.

The body temperature parameter is so significant that a doctor can easily predict the problem patient is going through and also will save time. The project is very helpful for the people living in remote areas and doesn't have access to all the medical facilities. This can be signified as a small home clinic where u can just sit and get a regular check up done.

#### **7.1 RISK AND CHALLENGES:**

The protect saved a lot of work and load for the patient as well as the doctor but a physical presence and checkup is considered more appropriate in some cases. Although the cloud data is completely protected and mostly cannot be harmed yet there are sometimes security issues. Deliberately upsetting and disturbing the system is another danger to Internet things in the human services industry. Unlike any other innovation this can also be harmed by the online hackers and programmers and hence security come ups to be the major challenge here.

## **7.2 UPCOMING UPGRATTION:**

The idea of mobile medicinal service will be a newly invented and different approach for the country. People can get the normal and routine checkup done at home and more easily as they used to. Utilizing the knowledge of sensors and internet this project will help every person all over at any moment at any time. Reporting problem over time to the doctor can save a life moreover can help someone to get a proper treatment.



## REFERENCES

[1] OvidiuApostu, BogdanHagiu, Sever Paşca, “ Mobile Telemedicine System for Home Care and Patient Monitoring Using ZigBee”2011 The International Symposium on ADVANCED TOPIC INELECTRICAL ENGINEERING2068-7966/ATEE2011.

[2] Warsuzarina MatJubadi, SitiFaridatulAisyahMohd , “Patient Health Management” System Using E-Health Monitoring Architecture”, 978-1-4244-4683-4/09/25.00 ©2009 IEEE.

[3] M. V. M. Figueredo, J. S. Dias, "Internet of Things: Remote Patient Monitoring Using Web Services and Cloud Computing". Proceedings Of The 26th Annual International Conference Of The IEEE San Francisco, Ca, USA, September 1-5,2004.

[4] Pei-Cheng HI, Wan-Young Chung, "Health Gear: A Real-Time Wearable System for Monitoring and Analyzing Physiological Signals", Sensors 2011,

[5] "Design and Development of E-Health Care Monitoring System" MajdiBsoul, Member, IEEE, HlaingMinn, Senior Member, IEEE.

[6] " Android Based Body Area Network for the Evaluation of Medical Parameters ",Moh. Rafi khan, International Conference Of The IEEE los angeles ,IEEE 2012.

[7]. Li, Rita Yi Man; Li, HerruChing Yu; Mak, Cho Kei; Tang, Tony Beiqi. “Smart home automation and intelligent home automation”

[10]. Preville, Cherie (August 26, 2013) “Control your castle: the latest in home automation”.

[11]. Asadullah, Muhammad (December 22, 2016). “An overview of home automation systems” document. IEEE Accessed December 22, 2016.

[13]. Jin, M .; Bekiaris-Liberis, N .; Weekly, K. Spanos, C. J .; Bayen, A.M. (2016-01-01). “Occupancy detection by environmental detection”, IEEE Transactions in Engineering Science and Automation.

[14]. Berger, Lars T.; Schwager, Andreas; Pagani, Pascal; Schneider, Daniel M. (February 2014) “ Smart Grid Applications, Communications and Security.Devices, circuits and systems”.

[16]. Griffiths,Melanie(June 2016). “Smart Home Security. Construction of houses and renovation ”. Retrieved February 27, 2012.

[20]. “Best Home Automation System - Consumer Reports”;. Accessed 22/11/2011

[25]. "IoT experts worry about fragmentation - Mobile World Live";  
Mobile

World Live. 2016-02-25.

[26]. "Fragmentation is the enemy of the Internet of Things |

Qualcomm";. Qualcomm 2016-02-19.

[27]. "Internet of Things: Opportunities and Challenges for  
Semiconductor

Businesses";. McKinsey &