

**EFFECT OF GEOTEXTILE ON SHEAR STRENGTH OF  
MUNICIPAL SOLID WASTE SOIL**

*Submitted in partial fulfillment of the requirements for the award of the degree of*

**BACHELOR OF TECHNOLOGY**

**IN**

**CIVIL ENGINEERING**

Under the supervision of

**Mr. Saurav**

**Assistant Professor**

*By*

**Abhishek Kumar (131667)**

**Abhinav Gupta (131602)**



**JAYPEE UNIVERSITY OF INFORMATION TECHNOLOGY**

**WAKNAGHAT, SOLAN – 173 234**

**HIMACHAL PRADESH, INDIA**

**MAY-2017**

## **CERTIFICATE**

This is to certify that the work which is being presented in the project report titled “**EFFECT OF GEOTEXTILE ON SHEAR STRENGTH OF MSW SOIL**” in partial fulfillment of the requirements for the award of the degree of Bachelor of Technology in Civil Engineering and submitted to the Department of Civil Engineering, Jaypee University of Information Technology, Waknaghat is an authentic record of work carried out by Abhishek Kumar ( 131667) & Abhinav Gupta (131602) during a period from January to May under the supervision of **Mr.Saurav** , Assistant Professor, Department of Civil Engineering, Jaypee University of Information Technology, Waknaghat.

The above statement made is correct to the best of our knowledge.

Date: - .....

Dr. Ashok Kumar Gupta  
Professor & Head of Department  
Civil Engineering Department  
JUIT Waknaghat

Mr Saurav  
Assistant Professor  
Civil Engineering Department  
JUIT Waknaghat

## **ACKNOWLEDGEMENT**

The completion of any project depends upon cooperation, co-ordination and combined efforts of several sources of knowledge. We are grateful to our project guide Mr. Saurav for his even willingness to give us valuable advice and direction; whenever we approached him with a problem .We are thankful to him for providing immense guidance for this project.

We Abhishek Kumar and Abhinav Gupta would like to acknowledge our work on “**EFFECT OF GEOTEXTILE ON SHEAR STRENGTH OF MUNICIPAL SOLID WASTE SOIL**”. We would like to express our special thanks of gratitude to our lab assistants Mr. Jaswinder Singh, Mr Narendra Kumar and Mr. Itesh Singh who gave us the full information regarding various lab equipments.

We are also thankful to Dr. ASHOK KUMAR GUPTA (Prof. & Head, Department of Civil Engineering) and all the staff members for their immense Cooperation and motivation for completing out our project.

## **ABSTRACT**

Laboratory tests were carried out on reinforced and unreinforced soil samples to determine the effect of geotextile on shear strength of Municipal solid waste sand. The variation of shear strength was studied by changing the number of layers of geotextile in the soil specimen. Preliminary soil investigation was conducted to determine the index properties of the sample and classify it. After classification it direct shear test were conducted on the silty sand sample and results analyzed. The tests were carried out on unreinforced and reinforced specimens with 1, 2 and 3 evenly spaced geotextile layers under three different confining pressures to find cohesion and friction angle. It was concluded that the peak failure strain increases as the number of layers increases. The stress increase was much greater in three layer reinforcement than one layer. The cohesion value changes greatly as the number of layer increase whereas the friction angle value does not witness a similar mercuric rise. Bulging between layers was observed whenever the sample failed at each geotextile level. The failure envelopes were drawn as the best fit line for the Mohr circles.

Keywords: Geotextile, Silty Sand, Cohesion, Friction angle.

# CONTENTS

CERTIFICATE .....	II
ACKNOWLEDGEMENT .....	III
ABSTRACT .....	IV
CHAPTER 1 .....	1
INTRODUCTION.....	1
1.1 General.....	1
1.2 Applications Of Reinforced Soil .....	3
1.3 Coulomb’s Equation .....	4
1.4 Municipal Solid Waste Soil .....	4
1.5 Concept Of Reinforced Soil.....	5
CHAPTER 2 .....	8
LITERATURE REVIEW .....	8
2.1 General.....	8
2.2 Exemplary Studies .....	8
2.2.1 Vidal [8] (1969).....	8
2.2.2 Bassett and Last [16] (1978).....	8
2.2.3 Madhavi G. Latha1 and Vidya S. Murthy [17].....	9
2.2.5 Holtz (1982) [5,7].....	10
2.2.6 Dr. S. A. Moflz, &Dr. M. R. Taha [12].....	10
2.3 Factors Influencing Reinforced Soil.....	11
2.4 Problems With Fine Grained And Cohesive Soils .....	13
2.5 Objectives.....	14
2.6 Summary.....	14
CHAPTER 3 .....	15
SOIL INVESTIGATION AND CLASSIFICATION .....	15
3.1 Introduction.....	15
3.2 Index Properties of Soil .....	15

3.2.1 Grain Size Distribution .....	16
3.2.2 Sieve Analysis.....	16
3.2.3 Specific Gravity.....	18
3.2.4 Water Content .....	19
3.2.5 Optimum Moisture Content.....	19
<b>CHAPTER 4.....</b>	<b>22</b>
<b>MEASUREMENT OF SHEAR STRENGTH PARAMETERS .....</b>	<b>22</b>
<b>4.1 Direct Shear Test .....</b>	<b>22</b>
4.1.1 Reinforcement .....	24
<b>4.3 Experimental Program .....</b>	<b>24</b>
<b>CHAPTER - 5.....</b>	<b>26</b>
<b>RESULTS AND DISCUSSION .....</b>	<b>26</b>
<b>5.1 General.....</b>	<b>26</b>
<b>5.2 Test Results.....</b>	<b>26</b>
5.2.1 Grain Size Analysis:.....	26
5.2.2 Specific Gravity: .....	27
5.2.3 Compaction:.....	28
5.2.4 Direct Shear Test: .....	29
5.2.5 Free Swell Index: .....	33
<b>CHAPTER 6.....</b>	<b>34</b>
<b>SUMMARY AND CONCLUSION.....</b>	<b>34</b>
<b>6.1 Direct Shear Test: .....</b>	<b>34</b>
<b>6.2 Compaction: .....</b>	<b>34</b>
<b>REFERENCES.....</b>	<b>35</b>
<b>ANNEXURE.....</b>	<b>37</b>
<b>Annexure A: Particle size distribution.....</b>	<b>37</b>
<b>Annexure B: Specific Gravity by Pycnometer .....</b>	<b>38</b>
<b>Annexure C: Specific Gravity by Density bottle.....</b>	<b>39</b>
<b>Annexure D: Compaction test.....</b>	<b>40</b>
<b>Annexure E: Direct shear test (no layers of reinforcement) .....</b>	<b>41</b>
<b>Annexure F: Direct Shear Test (single layer reinforcement).....</b>	<b>43</b>
<b>Annexure G: Direct Shear Test (Double layer reinforcement).....</b>	<b>45</b>



## LIST OF FIGURES

<b>Figures</b>	<b>Description</b>	<b>Page Number</b>
<b>1.1</b>	Geotextile Arrangement used in the study	7
<b>3.1</b>	Sieves used for Grain Size Distribution	17
<b>3.2</b>	Grain Size Distribution Curve	17
<b>3.3</b>	Pycnometer Test for Specific Gravity	18
<b>3.4</b>	Proctor's Apparatus	20
<b>3.5</b>	Dry Density v/s water content	20
<b>3.6</b>	Experimental Data obtained from Proctor Test	21
<b>4.1</b>	Direct Shear Test Apparatus	23
<b>4.2</b>	Direct Shear Test Mould	23
<b>4.3</b>	Types of geotextiles	24
<b>4.4</b>	Geotextile Arrangement	25
<b>5.1</b>	Particle Size Distribution	26
<b>5.2</b>	Specific Gravity Bottle	27
<b>5.3</b>	Optimum Moisture Graph	28
<b>5.4</b>	Direct shear test on non-reinforced soil	29
<b>5.5</b>	Direct shear test on non-reinforced soil	30
<b>5.6</b>	Direct shear test on soil with single layer of reinforcement	30
<b>5.7</b>	Direct shear test on soil with single layer of reinforcement	31
<b>5.8</b>	Direct shear test on soil with double layer of reinforcement	32
<b>5.9</b>	Direct shear test on soil with double layer of reinforcement	33



# CHAPTER 1

## INTRODUCTION

### 1.1 General

Soil is known to resist shear and compression adequately. However, it has an inherent shortcoming of being weak against tension. Various attempts have been made to overcome this weakness of soil. Utilizing a tensile element within the soil mass, in order to improve its tensile strength is one of the methods employed. Reinforced soil is a composite material in which elements of high tensile resistance are implemented to increase the tensile resistance of the soil. Geosynthetics are the main materials used for increasing the resistance and stability of geotechnical structures all around the world.

There are many historical examples of constructions which use reinforcement elements strong in tension, to improve the strength and stability of soil. Some outstanding early structures are the Ziggurat of Agar-Quf in Iraq which is thought to be 3000 years old (Bagir, 1944) and the Great Wall of China. An early application of soil reinforcement for military construction was introduced by Col. Pasley in 1822, Jones (1985). Pasley showed that the lateral pressure acting on a retaining wall could be reduced significantly by reinforcing the backfill with horizontal layers of brushwood, wooden planks or canvas.

A notable development to the modern concept of reinforced soil structures was made in the United States by Andreas Munster in 1925. The structure consisted of an array of wooden reinforcing members jointed to the facing by using a sliding connection. In this way the problem associated with the settling of the backfill relative to the facing could be minimized. In 1929, Andre Coyne patented in Paris a multi-anchorage system used for the construction of retaining walls, especially for the structures such as dykes. Coyne's system, known as "mur a echelle" (ladder wall), was made up of successive horizontal elements, formed by a light facing element linked to either continuous or discrete anchors with ties. It has only been comparatively recently, that engineers have attempted to investigate and quantify the mechanics and processes

behind earth reinforcement so that a more scientific basis can be applied to the design of such structures.

The modern concept of reinforced soil was proposed by Casagrande, who idealized the problem in the form of a weak soil reinforced by high strength members laid horizontally in layers (Westergaard, 1938). The modern form of earth reinforcement was introduced and popularized by the French architect and engineer Henri Vidal [8] in the 1960s. Vidal's original proposal was for a composite material to be formed from flat metal (galvanized or stainless steel) reinforcing strips laid horizontally in a frictional fill, the interaction between the soil and the reinforcement being generated solely by surface friction. Vidal [8] called this material "terre armee" and took out patents in many countries including America, Canada and France. It soon became evident that this was a powerful new technique for the geotechnical engineer, and the 1970s and 1980s saw a rapid growth in interest in the method. Fundamental research work was sponsored by various national bodies, notably at the Laboratoires des Ponts et al Chaussées (LCPC) in France (Schlosser, and Vidal 1969)[8], by the US. Department of Transport (Walkinshaw, 1975) and by the UK. Department of Transport (Murray, 1977), as well as work done by individual researchers in a number of countries including Japan. Most of the research has been associated with the use of good quality frictional fills. Since then, many construction systems have evolved including the United Kingdom developments of the York Method, Jones (1978), the Transport and Road Research Laboratory (TRRL) anchored earth, Murray and Irwin (1981), the use of polymer anchors, Hassan (1992), and the Websol system, Kempton et al. (1985). The new systems utilize various different kinds of reinforcing materials including, geotextile nets, polymer strips anchors and grids and steel in the form of plates, bars, triangular anchors or grids. The facing units used are not restricted to reinforced concrete slabs, facing units made from other materials have been used, including glass reinforced plastics (GRP), glass-reinforced cement (GRC), geotextiles, steel, timber, and masonry. This development work has led to a steady improvement in the technology and the economies of reinforced soil. Much of the development has been associated with the desire to improve long term durability.

Geotextiles are preferred over any other metallic reinforcement these fabrics have relatively low stiffness compared to that of metals. This makes them more compatible with soil in view of deformability. Geotextiles, as reinforcing materials, not only increase shear strength but also

improve ductility and provide smaller loss of post-peak strength in reinforced sand in comparison with unreinforced sand.

Today, geotextiles have captured Civil Engineering industry around the globe, as viable and economical construction materials with multifarious uses. Mechanically stabilized earth (MSE) or geosynthetic-reinforced soil (GRS) retaining structures are being widely used by geotechnical engineers in various projects such as residences, highways, bridge abutments, embankments and slope stabilization. Mechanically stabilized earth also finds its application in transportation engineering and related fields. One of the most important applications of geotextiles is in the construction of reinforced slopes and embankments to increase the shearing resistance of the soil and to allow for construction and design of steeper slopes. Use of geotextiles ensure ease of construction, excellent seismic performance, and a good ability to withstand large deformations without structural deformation or distress. This makes MSE structures desirable. Additionally, retaining structures constructed with reinforced soil are aesthetically good, reliability, and low in cost. Although MSE or GRS structures have many applications, the design of these structures has not been optimized due to the complex interaction between soil and reinforcements.

## **1.2 Applications Of Reinforced Soil**

Reinforced soil structures can be shown to provide economic advantage over a wide range of conventional constructions, Jones (1990). An example of the scope for savings is shown in bridgeworks where overall savings of up to 50 percent are possible by selecting a reinforced soil option when constructing the abutments. A major advantage of reinforced soil is the improved idealization which the concept permits, this results in structures, which would otherwise have been difficult or expensive to construct being considered. Because of its flexibility reinforced soil is particularly suited for use over compressible foundations or poor ground conditions. Based on their applications, reinforced soil can be subdivided into three broad categories: (i) earth structures, (ii) load supporting structures and (iii) a combination of (i) and (ii).

(i) Earth structures Earth structures include slopes, walls, and embankments. Earth structures do not normally support significant external loads, and the primary design consideration is the stability of the structure under its own weight. In some cases facing is required especially for vertical or near vertical reinforced soil walls.

(ii) Load supporting structures Load supporting structures include building foundations, flexible pavements, unpaved roads, railroad track structures, and load supporting pads such as drilling pads, fabrication yards, and construction staging areas.

(iii) Combination of (i) and (ii) The combination of (i) and (ii) are exemplified by structures such as bridge abutments, piled embankments, walls supporting railroad tracks and earth works supporting structures. The design of these structures takes into account both dead and live loads.

### **1.3 Coulomb's Equation**

Coulomb observed that one component of the shearing strength, called the intrinsic cohesion, (sometimes called apparent cohesion), is constant for a given soil and is independent of the applied stress. The other component, frictional resistance somewhat similar to sliding friction in solids varies directly as the magnitude of the normal stress of the plane of rupture. Coulomb's equation is written as:  $\tau = c + \sigma \tan \phi$  Shear Strength of the soil

$c$  = cohesion  $\sigma$  = normal stress of the plane of rupture  $\phi$  = angle of internal friction

$c$  and  $\phi$  are also referred to as the shear strength parameters of soil. For purely cohesive soils the friction angle is zero and shear strength is governed by cohesion only. For purely cohesion less soils  $c$  is zero and  $\phi$  is a substantial value.

### **1.4 Municipal Solid Waste Soil**

Environmental pollution has been haunting the modern world due to excessive growth in developing countries. Main sources for Municipal solid waste generation are human settlements, small industries and commercial activities. Wastes from clinics and hospitals also find its way to Municipal solid waste. These wastes when mixed with Municipal solid waste pose a threat on health as well as the environment. Due to low budget on waste disposal and lack of trained manpower, open dumping is a common practice among the developing countries. This causes a serious threat to groundwater resources and soil. Contamination of soil by heavy metals have adverse effects on human and animal health and soil productivity (smith et al., 1996). Over the years, metals have damaged the soil quality and fertility in consequence of increased environmental pollution from industrial, agricultural and municipal sources (Adriano, 1986). The pollutants, in the first place hinder the normal metabolism of plants which is an invisible injury

and owing to which visible injury appears in the aftermath (Ahmed et al., 1986). Pollutants act as an external agent in affecting the physic-chemical properties of soil (papageorgiou, 2006). In this regard, developing countries are unable to upgrade their disposal facilities due to poor financials and are vulnerable to hazards of dumping for their environment (Hazra and Goel, 2009). The material is much different from soil, it has (a) High organic content (b) Low density (c) High water absorption. The use of Municipal solid waste soil may result in long term settlements and may result in failure of Road built over it. Compaction in the field is another problem due to presence of heterogenic characteristics of Municipal solid waste soil i.e. presence of plastics, papers, clothes etc.

### **1.5 Concept Of Reinforced Soil**

Soils deform in shear before insatiably along a slip surface can occur. In common with other materials, shear deformation in soil causes compressive and tensile strains to develop. Stability in soil is provided by frictional shearing resistance, derived from particle friction, particle shape, packing, and compressive stresses. The driving forces causing failure in a soil mass must overcome the frictional shearing resistance if a slip surface is to develop. Soil may be strengthened by reinforcement which exploits these features of soil behavior making them work together. The reinforcement needs to be placed in the direction of tensile strain so that deformation in the soil generates tensile force in the reinforcement. The result of tension forces being developed in the reinforcement is to improve the soil. This can be illustrated by a direct shear test on a frictional soil. Compressive and tensile strains must occur for a shear surface to develop through the soil. In the shear tests the applied disturbing force  $P$ , is resisted by the frictional resistance in the soil. Shear deformation in the soil causes a tensile force,  $R$ , to develop in the reinforcement. Geotextiles upgrade the mechanical properties of soils by three mechanisms:

- They enhance the bonds in the soil. This is because the soil particles interlock with the reinforcement apertures.
- They contribute to the shear resistance of the soil depending on the direction of reinforcements with respect to the failure plane of the given soil.
- They increase the lateral stresses by limiting the lateral deformations.

Geotextiles also perform the functions of drainage, filtration and act as a separator in addition to being used as reinforcement. However, due to the lack of information on the mechanisms of action of geosynthetic materials used as reinforcement for soil, their uses and applications have not been completely exhausted. Similarly, their combined function of drainage and reinforcement which could be offered by some geosynthetic materials has not been studied.

Any study of the function of geotextiles embedded in soil would require:

- A detailed study of the behavior of the reinforcing function of the geosynthetic materials with the soil.
- The mechanisms of interaction between the geotextiles used and the soil.
- Measurement of the shear strength parameters of the soil i.e. its angle of internal friction ' $\phi$ ' and cohesion ' $c$ ' with and without geotextiles acting as reinforcement, drainage or as a combined function.
- The development of suitable a suitable modelling procedure for analysis which could be used to accurately predict the behavior of reinforced soil using cohesive fill and containing geosynthetics.

This thesis revolves around the study of variation of shear strength parameters of soil with various layers of reinforcement. In this respect, a review of the geotechnical literature on geotextile-reinforced soils for element testing reveals that most of the studies have been carried out either in the triaxial apparatus with compression loading or in the direct shear apparatus. Direct shear focuses mainly on the soil-geotextile interface behavior. However, the direct shear test is plagued with a number of disadvantages. Hence, for the purpose of our study, tests were conducted on the triaxial apparatus. A comparative study has been conducted by altering the number of layers of geotextile provided for reinforcement purpose. These cases have been pictorially depicted below in figure 1.1.

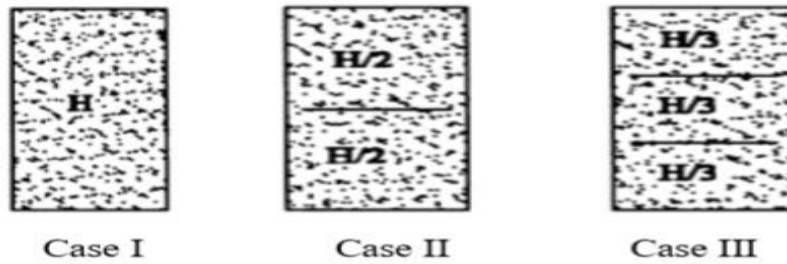

Figure 1.1 Geotextile arrangement used in the study

Here, Case I depicts an Municipal solid waste soil sample of height  $H$  without any layers of reinforcement.

Case II, is the case where the Municipal solid waste soil has been provided with a uni-layer reinforcement symmetrically dividing the sample into two equal halves of height  $H/2$ .

Case III, deals with dual layer of reinforcement. The geotextile layers have been provided at the heights  $H/3$  and  $2H/3$  from the top.

## CHAPTER 2

### LITERATURE REVIEW

#### 2.1 General

This chapter reviews briefly the history and development of soil reinforcement techniques, with special emphasis on the mechanism of reinforcement, the development of design theories and the reinforcing materials and fills used. Although, the experimental results could not be used directly in the design of reinforced earth structures, they provide an efficient, fast and economical method for investigating and understanding the behavior of reinforced earth. The main objective of this paper is to present the results of direct shear test on reinforced dry sand with different layering of available geotextiles. In this study in addition to describing the influence of confining pressure, the number of geotextile layers, and various kinds of geotextiles which have been previously investigated by many researchers, the effects of sample size and geotextile arrangement (in a comprehensive manner) on the test results are also illustrated which have not been reported yet .

#### 2.2 Exemplary Studies

##### 2.2.1 Vidal [8] (1969)

He demonstrated the increase of strength by considering two specimens, one (specimen A) formed with soil and the other (specimen B) with soil and a single horizontal layer of reinforcement placed at mid-height. Vidal [8] demonstrated that due to the self-weight of the specimens, the vertical pressure and a minimum confining pressure of had to be applied to both the specimens to maintain equilibrium.

##### 2.2.2 Bassett and Last [16] (1978)

Gave a very important theoretical contribution to the subject of reinforced soil .They pointed out that the mechanism of tensile reinforcement involves anisotropic restraint of the soil deformation in the direction of the reinforcements Due to the soil-reinforcement interaction the presence of



reinforcement in a soil mass modifies the strain and stress patterns.

### *2.2.3 Madhavi G. Latha1 and Vidya S. Murthy [17]*

Geosynthetic reinforced samples exhibited improved stress-strain response in triaxial compression compared to unreinforced sand at all confining pressures and all layer configurations, in terms of high peak deviator stress and large failure strains. Among the three types of geosynthetics, geogrid is found to be inferior compared to the other two types in all layer configurations because of its inferior load-elongation characteristics. Polyester film proved to be highly efficient in improving the strength of sand in all configurations, though its tensile strength is less than that of geotextile. This unusual behavior is due to the formation of indents on the surface of polyester film due to sand particle penetration. Special triaxial compression tests on rice flour reinforced with geosynthetics revealed that in the absence of indents, improvement in strength is governed by the tensile strength of reinforcing material. Microscopic images of polyester film and geotextile before and after triaxial test and surface roughness studies using profilometer support the effect of indent formation.

### *2.2.4 Hosseinpour, S. H. Mirmoradi, A. Barari, M. Omidvar [3]*

In this paper, a numerical analysis was conducted to study the effect of sample size on different types of geotextile-reinforced sand. Results showed that triaxial tests may be effectively and accurately modelled by means of numerical analysis via the finite element method. Performing triaxial tests on large sized samples using numerical modelling is extremely efficient and economical. The use of numerical modelling of experimental setups for studying the behavior of reinforced soil for practical applications where time and economical restrictions apply provides an attractive alternative to actual experimental testing. This survey has led to the following conclusions:

- In general, geotextile considerably increases the peak strength and axial strain at failure of reinforced sand. The peak strength is further increased by increasing the confining pressure and the number of geotextile layers.
- Sample size has a remarkable effect on the mechanical behavior of reinforced sand compared with its effect on unreinforced samples. Hence, the sample of reinforced sand with smaller diameter had a remarkably higher peak strength and axial strain at failure

than the sample of reinforced sand with larger diameter, under the same conditions of geotextile layer and confining pressure.

- The size effect on the failure envelope of geotextile-reinforced sand increases with an increase in the friction angle between the sand and the geotextile.
- The size effect on the failure envelope of reinforced sand decreases remarkably with an increase in sample diameter and may be ignored for samples of diameters greater than 600 mm at a high confining pressure and with a low number of reinforcement layers.
- The study of the size effect on residual strength indicated that at a constant confining pressure, the residual strength ratio increases with a decrease in sample size.

#### *2.2.5 Holtz (1982) [5,7]*

Holtz et al. (1982) [5,7] conducted a number of long-term and short-term triaxial tests on dry sand reinforced by woven and nonwoven geotextiles. They also observed the influence of reinforcement on the creep of reinforced samples. Nakai (1992) investigated the stress-strain behaviour of reinforced sand using triaxial tests and finite element analysis. Triaxial tests were performed on Toyoura sand, and reinforcement layers in the form of brass sheets were employed. Some finite element analyses were also performed under the experimental conditions with only a quarter of the triaxial samples being modelled. Krishnaswamy and Isaac (1995) investigated the liquefaction susceptibility of geotextile-reinforced sand by conducting some cyclic tests. The tests were performed on 38-mm and 76-mm diameter sand samples with uniform grain size to determine the strength of the samples against liquefaction.

#### *2.2.6 Dr. S. A. Moflz, &Dr. M. R. Taha [12]*

In this paper, an experimental study is presented under various stress paths for unreinforced and reinforced soil. Drained triaxial tests were conducted using a computer controlled GDS triaxial apparatus. Test results show that non-woven geotextile reinforced soils exhibit higher failure strains and volume contraction than unreinforced soils. Failure strains and the strength increase with increase in number of layers. A simplified approach for numerical calculations was proposed to predict the shear strength and the coefficient of interface friction of reinforced soils for conventional triaxial compression (CTC) stress paths. Charts were also presented to predict the

strength of reinforced soil and to determine the coefficient of the interface friction from test results and predictions are satisfactory.

The strains in the soils due to a given increment of stress vary considerably depending on the stress-level and confining pressure. In the field, soil elements undergo different stress paths depending upon the loading condition. Reinforced soil has gained popularity due to its extensive application in various problems such as retaining walls, pavements, foundations, embankments, etc

### **2.3 Factors Influencing Reinforced Soil**

The design rules which are currently used in practice are largely based on empirical observations and measurements made on structures under working conditions. These rules have proved successful and have enabled stable reinforced soil structures to be built with confidence. Two shortcomings to the approach, however, are: the rules provide no information as to potential "weak links" in the structure, or how the design might be improved (in terms of the selection, spacing and orientation of the reinforcement for example), and

- The simple extension of the existing empirical rules to different types of reinforcement in different soils, and different geometries is not always possible.

It would be more satisfactory if an assessment of the behavior of a reinforced soil could be derived from consideration of the factors which influence its performance including:

- a) The mechanical behavior of the soil, described by standard parameters,
- b) The material properties and geometry of the reinforcement, an understanding of the mechanisms which operate when reinforcement is placed in soil (including the influence of the reinforcement properties, dimension, orientation and spacing in the soil),
- c) The influence of construction

A comprehensive list of the factors which influence a reinforced soil structure is given in

- a) Reinforcement

Reinforcement when introduced into soil and aligned with the tensile strain direction disrupts the uniform pattern of strain that would develop if the reinforcement did not exist. The reinforcement also inhibits the formation of continuous rupture surfaces through the soil, with the result that the soil exhibits an improved stiffness and shear strength.

b) Form In order to improve the performance, the reinforcement must adhere to the soil or be so shaped that deformation of the soil produces strain in the reinforcement. Reinforcement can take many forms depending largely upon the material employed. Some reinforcement such as plain strips, rely upon friction to develop bond between the soil and reinforcement; the grid and the anchor provide a more positive, bond by developing an abutment effect or soil reinforcement interlock. The performance of various forms of reinforcement in respect of bond has been studied by a number of researchers and performance criteria for frictional fill and established reinforcement have been developed by Schossler and Elias (1978) for strips, Milligan and Love (1989) for grids, Murray (1983) for triangular anchors, and Hassan (1992) for polymer anchors.

c) Stress distribution along reinforcement: In the case of grid reinforcement, the width of the reinforcement is not restricted by the actual material section of the reinforcement but by the dimensions of the traverse elements and the shear strength of the soil. The mechanism of action of a grid in providing resistance to is discussed by Milhigan (1982).

Among the mechanisms proposed is the passive resistance theory Chang et al (1977) and the bearing capacity theory Bishop et al (1982). The bearing capacity mechanism is a form of passive resistance with a limited failure plane; however, it has been concluded that the passive resistance mechanism may be true for a completed grid but does not hold for individual transverse members, Milligan and Love, (1985).

d) Surface properties For sheets, bars and strips, the coefficient of friction between the reinforcement and soil is a critical property, the higher the friction the more efficient the reinforcement. Thus an ideally rough bar, strip or sheet is significantly better than a reinforcement with a smooth surface.

e) Dimensions: The dimension of the reinforcement must be compatible with the requirements of the structure. The theoretical dimensions of any reinforcement are likely to be modified to conform

to the requirements of logistics, durability, and minimum specification requirements, BS 8006 (1991). In addition the form, strength, stiffness and spacing will all influence the dimensions chosen.

f) Strength: Reinforcement strength is synonymous with robustness; logic demands that any reinforcement be robust. Any sudden loss of strength could have catastrophic effects since the improvement in shear strength is directly dependent upon the magnitude of the maximum force generated in the reinforcement. Sudden loss of strength due to failure, would have the effect of suddenly reducing the shear strength of the reinforced soil to the shear strength of the soil shown at an equivalent displacement.

g) Stiffness: Bending stiffness ( $EI_{ly}$ ), is the product of the elastic modulus,  $E$ , and the second moment of area,  $I$ , it has not been shown to have any significant effect on the performance of reinforced soils. Longitudinal stiffness is a critical parameter as this determines the stress state of the soil-reinforcement composite material, a point acknowledged in recent design Codes, BS8006 (1991), Jones (1992).

## **2.4 Problems With Fine Grained And Cohesive Soils**

The soil materials used in reinforced soil structures are dependent on the technical requirements of the structures and the basic economies associated with it. The main load transfer mechanism in reinforced soil structures is dependent on the shear forces developed at the soil-reinforcement interface. This major requirement of frictional force has led to the use of cohesionless or cohesive frictional soils with high friction angles. Most codes of practice and most design methods are based on the use of a suitable frictional soil. The main reasons why fine grained and cohesive soils are generally held to be unsuitable for reinforced soil construction have been discussed by a number of authors including Long (1977), Mckittrick (1978), and Jewell and Jones (1981). The main problems are:

a) Short term stability: The bond between cohesive soil and strip reinforcement is poor and subject to reduction if positive pore water pressures develop. It is unlikely that the current, largely empirical design methods for reinforced cohesion less soils may be satisfactorily applied to cohesive soils.

b) Corrosion: Fine grained cohesive soils are significantly more aggressive than cohesion less soils.

c) Post-construction movements: It is thought that long term creep deformations might occur when plastic soils are reinforced. Unacceptable creep strains have been known to occur, Elias and Swanson (1978)

## **2.5 Objectives**

- Study of Geotechnical properties of soil (source: Landfill).
- Study of Reinforcement in soil.
- Comparison between Reinforced soil and Original soil sample.

## **2.6 Summary**

The presence of an inclusion can favorably affect the behavior of the soil-reinforcement composite. Various design approaches based on theoretical and experimental work have been suggested by a number of researchers. A comprehensive range of National structural codes have been devolved indicating that reinforced soil is an accepted structural technique. All current codes suggest that good quality cohesion less soil is required to constructed permeable reinforced soil structures. In some Countries good quality frictional fills are difficult to obtain at economic rates consequently the use of reinforced soil is limited. However, cohesive soils are available and soil structures could be built with these materials. Steep reinforced soil structures using cohesive fill reinforced with geotextiles have been constructed successfully. There is a lack of information in respect of the theory concerning reinforcement of cohesive soils and the importance of drainage when using these materials. The reinforcements which offer the potential of being suitable for use with fine grained soils are geogrids and geotextiles.

## **CHAPTER 3**

### **SOIL INVESTIGATION AND CLASSIFICATION**

#### **3.1 Introduction**

In nature, soils occur in a large variety. However, soils exhibiting similar behavior can be put together to form a particular group. Soils can also be put into major and minor groups. Various classification systems in practice place these soils in different categories based on certain properties of soil. The tests carried out in order to classify a soil are termed as classification tests. The numerical results obtained on the basis of such tests are termed index properties of soil. Soil properties are affected due to its composition, place of origin, type of origin, mode of transportation etc. Major components of any soil are silt, sand, clay, organic soil, pebbles and humus. Any soil sample can be broadly classified as silt, sand or clay according to various parameters and properties possessed by the soil. Soil classification is carried out on the basis of soil particle size and its gradation. If more than 50% particles are of size less than 75 micron, the soil is classified as clay. Soil classification requires some preliminary testing and calculation of a few parameters. For this purpose, various tests are performed in the laboratory. The classification requires calculation of grain size distribution, Liquid Limit and Plastic Limit.

#### **3.2 Index Properties of Soil**

The Index Properties of soils can be divided into two categories, namely,

(i) Soil grain properties (ii) Soil aggregate properties.

Soil grain properties are those properties which are dependent on the individual grains of the soil and are independent of the manner of soil formation. The properties in this category are composition, specific gravity, size and shape of grains. Soil aggregate properties are those properties which depend on the soil mass as a whole and represent a collective behavior of soil.

### *3.2.1 Grain Size Distribution*

Grain-size distribution or the percentage of various sizes of soil grains present in a given dry soil sample, is an important property. To obtain the grain size distribution of the given sample, two tests are generally conducted- Sieve Analysis. This test methods cover the quantitative determination of the distribution of particle sizes in soils. The distribution of particle sizes larger than 75 micrometers is determined by sieving. The tests further enlighten us about the percentages of various sizes of particles present in the soil sample which help in classifying the soil as coarse grained or fine grained. Two parameters namely Coefficient of Curvature and Coefficient of Uniformity are computed using sieve analysis.

### *3.2.2 Sieve Analysis*

Sieves are wire screens having square openings. Sieves vary in size from 80mm to 75 $\mu$ . The representative sample was separated into fractions by sieving through 4.75mm I.S. sieve. The fraction retained on this sieve (called gravel fraction) was subjected to further sieve analysis. A representative oven dried sample of soil that weighed about 1000 g was initially taken. (This soil sample had the greatest particle size of 4.75 mm). The sieves were cleaned and the soil particles stuck in the pores were brushed off. The sieves were then stacked. Sieves having larger opening sizes (i.e. lower numbers) were placed above the ones having smaller opening sizes (i.e. higher numbers). Sieve of sizes 425 $\mu$ , 300  $\mu$ , 150  $\mu$  and 75  $\mu$  were taken as the soil initially taken was already sieved through 200mm. A pan was placed under the 75  $\mu$  sieve to collect the portion of soil passing it. Stack was then placed and fixed over a sieve shaker. The amount of soil retained on each sieve was taken and weighed. The cumulative percentage of weight of soil passing through a sieve was plotted against the soil particle on a log graph. Using this curve, called the grain size distribution curve, the coefficient of uniformity and coefficient of curvature were computed. The sieves used for grain size distribution are shown in figure 3.1



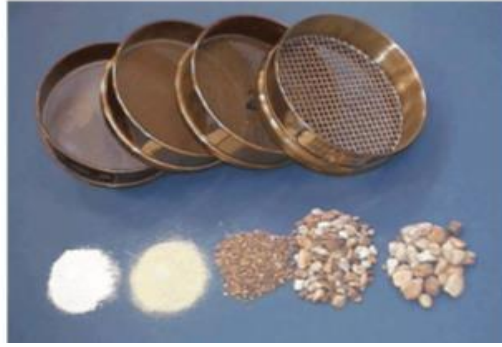

Figure 3.1: Sieves used for Grain size distribution

A well graded soil has a good representation of grain sizes over a wide range and its gradation curve is smooth. On the other hand, a poorly graded soil either has an excess or a deficiency of certain particle sizes or has most particles of about the same size. In the latter case, the soil is known as uniformly graded. A gap graded soil is the one in which some of the soil particles are missing. The following figure shows the grain size distribution curve in which we can see that soil properties lies in the range of medium sand.

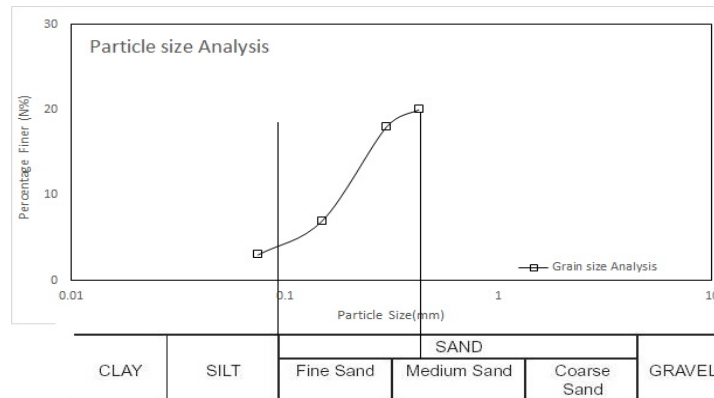

Figure 3.2: Grain Size Distribution Curve

$D_{10}$  corresponds to the diameter of which 10% of the particles are finer. The diameter  $D_{10}$  is known as the effective size.

Coefficient of uniformity is a shape parameter and is defined as

$$C_u = D_{60} / D_{10} \tag{Eq. 3.1}$$

Coefficient of Curvature is also a shape parameter and is defined as

$$Cc = \frac{(D_{30})^2}{D_{10} \times D_{60}} \quad (Eq. 3.2)$$

The coefficient of uniformity defined as the ratio of  $D_{60}$  and  $D_{10}$  was computed to be 5.98. The Coefficient of curvature for the given soil was 1.41. Hence the soil was poorly graded.

### 3.2.3 Specific Gravity

Specific gravity is the ratio of the density of a substance to the density (mass of the same unit volume) of a reference substance. Apparent specific gravity is the ratio of the weight of a volume of the substance to the weight of an equal volume of the reference substance. The reference substance is nearly always water at its densest, (4°C). Specific Gravity is frequently required for computation of several quantities such as void ratio, degree of saturation, unit weight of soil etc. It is determined using a Pycnometer. The weight of the empty clean and dry pycnometer was recorded as  $W_1$ . The dry soil sample was placed in the pycnometer. The weight of the pycnometer was  $W_2$ . Distilled water was added to fill the pycnometer. The pycnometer was gently shaken to dispel any air bubbles. Recorded weight was denoted by  $W_3$ . The contents of the pycnometer were removed and it was filled with distilled water till the top. Recorded weight of the completely distilled water filled pycnometer was  $W_4$ . Figure 3.3 shows different arrangement of soil, water in pycnometer.

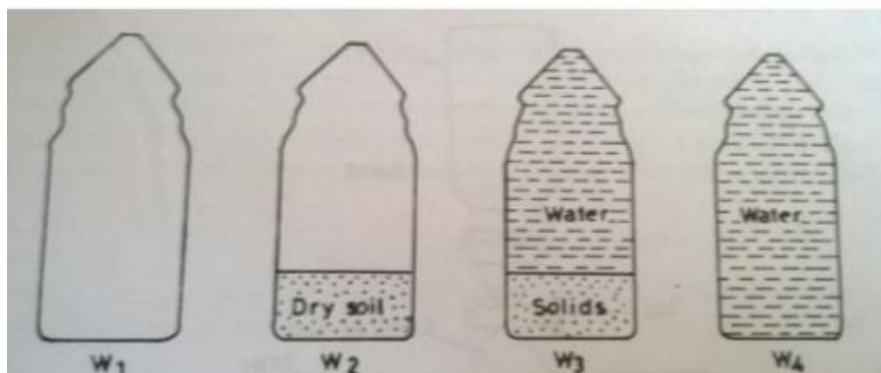

Figure 3.3: Pycnometer Test for determination of Specific Gravity

$$\text{Specific Gravity} = (W_2 - W_1) / (W_2 - W_1 - W_3 + W_4) \quad (\text{Eq. 3.7})$$

The Specific Gravity was computed to be **2.04**.

### *3.2.4 Water Content*

This test is conducted to determine the water content of the soil by oven drying method as per IS: 2720 (Part II) – 1973. The water content ( $w$ ) of a soil sample is equal to the mass of water divided present in the soil by the mass of solids. The temperature of oven should not exceed  $110 \pm 5^\circ\text{C}$  in case of normal soil and  $600^\circ\text{C}$  if organic in nature. This is because organic soils tend to possess water of crystallization that breaks away and alters the chemical configuration of the soil if the temperature exceeds  $600^\circ\text{C}$ .

The soil specimen taken was such that it is representative of the soil mass. (The quantity of the specimen taken would depend upon the gradation and the maximum size of particles as under.) The container was cleaned and dried. It was then weighed (Weight 'W1'). The required quantity of the wet soil specimen was taken and placed on the container. It was weighed. (Weight 'W2'). The container was kept in the oven till its weight became constant (i.e. for 24hrs.). When the soil had dried, the container was removed from the oven, using tongs and weighed 'W3'.

The water content “ $\omega$ ” is given by-

$$\omega = (W_2 - W_3 / W_2 - W_1) * 100 \quad (\text{Eq. 3.8})$$

### *3.2.5 Optimum Moisture Content*

At low water content, the soil is stiff and the soil grains offer more resistance to compaction. As the water content increases, the particles develop larger and larger water films around them, which tend to lubricate the particles and make them easier to work around, to move around into a denser configuration, resulting in higher dry unit weight and lower air voids. The dry unit weight increases with increase in moisture content. As the water is further increased, the water particles start to

replace the soil grains thus reducing the density of soil.

Proctors Compaction is conducted to determine the optimum water content. (Water content corresponding to maximum dry density). The proctor's apparatus is shown in figure 3.4

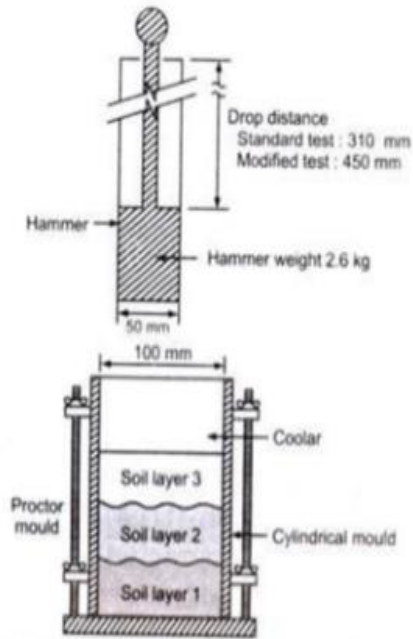

Figure 3.4: Proctor's Apparatus

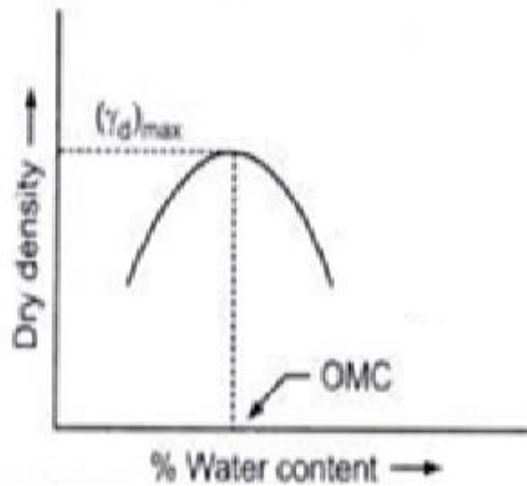

Figure 3.5: Dry density v/s water content curve

Dry density is given by

$$\gamma_d = \gamma_t / \omega - 1 \quad (\text{Eq 3.9})$$

Here,  $\omega$  is the water content and  $\gamma$  is the density obtained at the given water content. Figure 3.6 shows the graph between moisture content and dry density by which optimum moisture content is known.

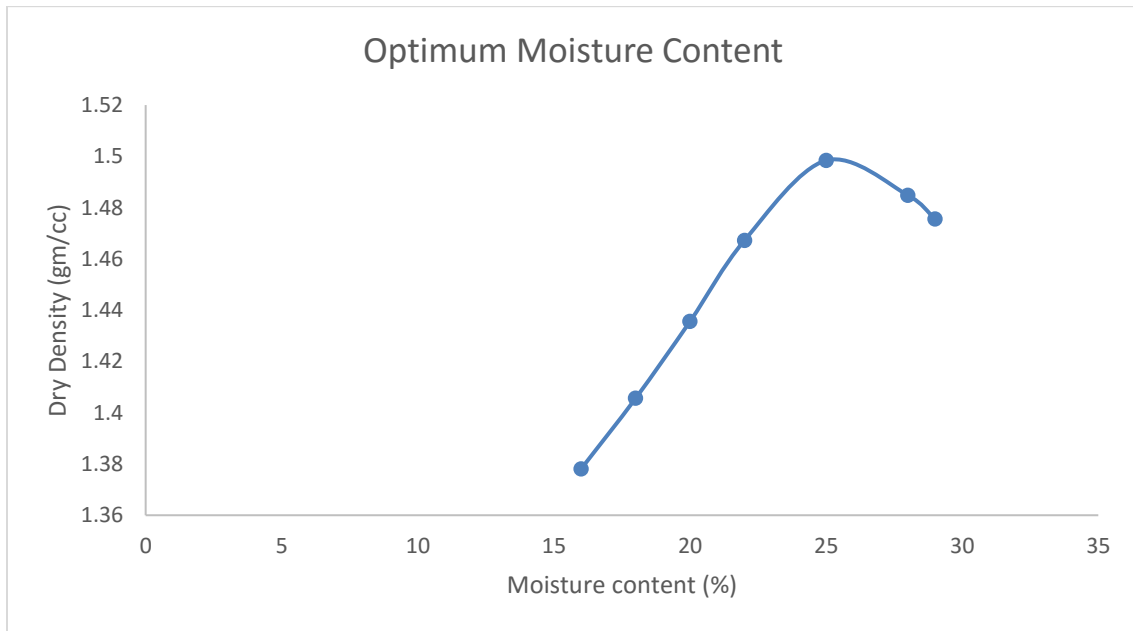

Figure 3.6: Experimental Data obtained from Proctor Test

5 Kg. of soil was taken passing through 75 micron sieve was taken. Water was added to it to bring its moisture content to about 8%. The mould with base plate attached was weighed. The extension collar was attached with the mould. Then the moist soil in the mould was compacted in 3 equal layers, with 25 blows from the 2.6 Kg hammer on each layer. The extension was removed and the compacted soil was levelled off carefully to the top of the mould by means of a straight edge. Then the mould and soil was weighed. The soil was removed from the mould and a representative soil sample was obtained for water content determination. The process repeated again after adding suitable amount of water to the soil in an increasing order. The optimum moisture content was **25%**.

## CHAPTER 4

### MEASUREMENT OF SHEAR STRENGTH PARAMETERS

Shear strength is perhaps the most important property of soil. It is measured in terms of cohesion and friction angle according to Coulomb's theory (ref). There are numerous tests available today for measuring the shear strength of any soil sample. The most common ones are listed below

1. Direct Shear Test
2. Triaxial test
3. Unconfined Compressive strength test
4. Vane shear test
5. Special shear tests

Each of these tests has their own advantages and shortcomings. Information about direct shear tests has been presented in great detail as they have been conducted on the reinforced and unreinforced soil sample.

#### 4.1 Direct Shear Test

IS: 2720 (Part 13) - 1986 deals with the method for direct shear test of soils. The controlled strain type of direct shear test provides accurate results and is, therefore, recommended.

Cohesive soils may be compacted to the required density and moisture content into the shear box by using the fixing screws to place the two-halves of the shear box together whereas cohesion less soils may be tamped in the shear box itself with the base plate and grid plate in place at the bottom of the box.

The load dial readings obtained are used to calculate loads. The loads so obtained divided by the corrected cross-sectional area of the specimen gives the shear stress.

The test results are plotted in form of a graph in which the applied normal stress is plotted as abscissa and the maximum shear stress is plotted as ordinate. The angle which the resulting straight line makes with the horizontal axis shall be reported as the angle of shearing resistance and the intercept which the straight line makes with the vertical axis as the cohesion intercept. Figure 4.1 shows direct shear test apparatus and figure 4.2 shows the mould in which sample is prepared.



Figure 4.1: Direct shear test apparatus



Figure 4.2: Direct shear test mould

#### 4.1.1 Reinforcement

Geosynthetics are man-made products used to stabilize earth. They could be both- natural and manmade in origin. Geotextiles, Geomembranes, Geonets, Geogrids, Geocells and Geocomposites are types of Geosynthetics.

For experiment purpose, geotextile has been used for soil reinforcement. As per the American Society for Testing and Materials (ASTM), a geotextile is any permeable textile material used with foundation, soil, rock, earth etc. that is an integral part of a constructed project, structure or system. It may be made of synthetic or natural fibers. Modern geotextiles are made up of synthetic polypropylenes, polyesters, polyethylene and polyamides which do not get biologically or chemically decayed with the course of time. Figure 4.3 shows the types of geotextiles that can be used.

Geotextiles are of various types-



a) Non-Woven



b) Woven



c) Knitted

Figure 4.3: Types of Geotextiles

### 4.3 Experimental Program

Direct shear test were performed to investigate the behavior of Unreinforced and reinforced silty soil sample under principal stresses. The test was conducted at the optimum moisture content i.e. Maximum dry density.



The Load used were  $0.5 \text{ kg/cm}^2$ ,  $1.0 \text{ kg/cm}^2$  and  $2.0 \text{ kg/cm}^2$ . Numerous arrangements of geotextiles varying in terms of number of layers of reinforcement were analyzed in this study. As observed from the preliminary soil investigation the soil sample was neither pure sand nor pure clay but silty sand. Figure 4.4 shows the arrangement of geotextile used in the soil sample.

The various arrangements of geotextile are:

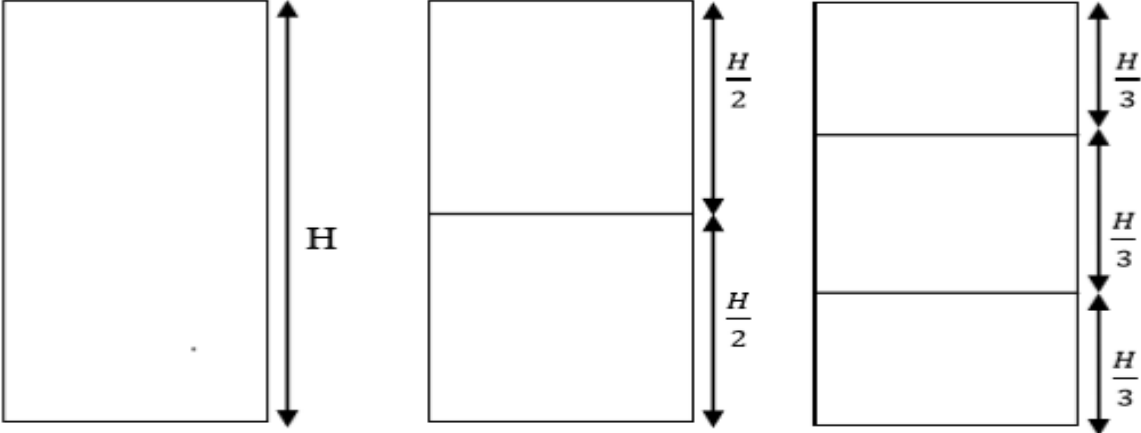

Figure 4.4: Geotextile arrangement used in this study

## CHAPTER - 5

### RESULTS AND DISCUSSION

#### 5.1 General

We obtained the municipal solid waste soil sample of Ghazipur landfill from CRRRI after segregating and proper classification of soil. We tested the Municipal solid waste soil sample with geotextile. The information and results furnished in the CSIR-CRRRI report have been taken as standards for comparison throughout the testing. The results pertaining to the tests that were performed on the material are summarized as below:

#### 5.2 Test Results

##### *5.2.1 Grain Size Analysis:*

Dry sieve analysis to determine the variation in grain size characteristics. The soil has more than 50% particles larger than 0.075mm and has a good representation of particles of all sizes ranging from 0.075mm to 4.75mm. The Uniformity Coefficient came out to be 5.98 and the Coefficient of gradation came out to be 1.41. Hence, we conclude that the Municipal solid waste sample constitutes **well graded sand (SW)**.

The soil particle size lies in the range of sand, possibly due to ongoing decomposition of materials in landfill. The soil used is relatively new (10 years old) hence the process of degradation of Municipal solid waste soil materials is not complete. The following figure 5.1 shows the grain size distribution curve in which we can see that are soil properties lies in the range of medium sand .

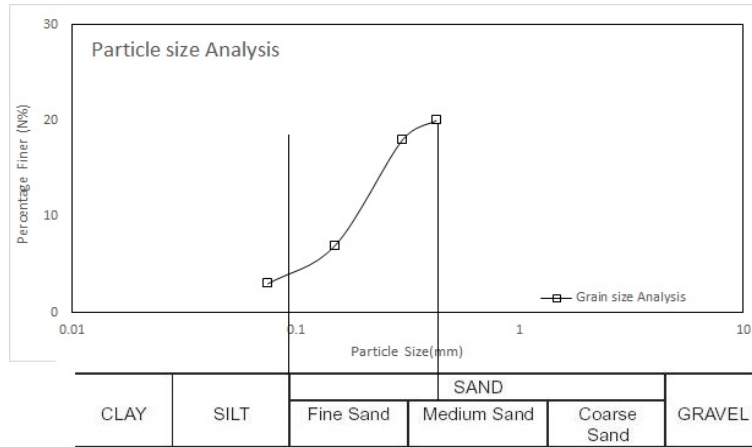

Figure 5.1: Particle size distribution

*5.2.2 Specific Gravity:*

The specific gravity test for the soil sample to be used was found out using pycnometer and later checked by using density bottle. The specific gravity of Municipal solid waste soil came out to be **2.04** using pycnometer indicating the presence of organic content in this soil.

The organic content in soil may be present due to decomposition of organic matter such as plant and animal residues, sewage sludge, carbon compounds, soil nutrients, microbes etc.

Organic nature of this soil may cause low bulk density, high water holding capacity and low load-bearing strength of soil, hence it must be calculated.



Figure 5.2: Specific gravity bottle

### 5.2.3 Compaction:

The Modified Proctor Test was carried out on this soil since it contained larger sized particles (sand) which requires higher compaction effort for breaking into smaller particles, filling up the voids and causing proper compaction. The test resulted in a **maximum dry density** of **11.75kN/m<sup>3</sup>** the **optimum moisture content** of **25%**.

Maximum dry unit weights may range from around 10kN/m<sup>3</sup> for organic soils to about 23kN/m<sup>3</sup> for well graduated, granular material containing just enough fines to fill small voids. Figure 5.3 shows the graph between moisture content and dry density by which optimum moisture content is known.

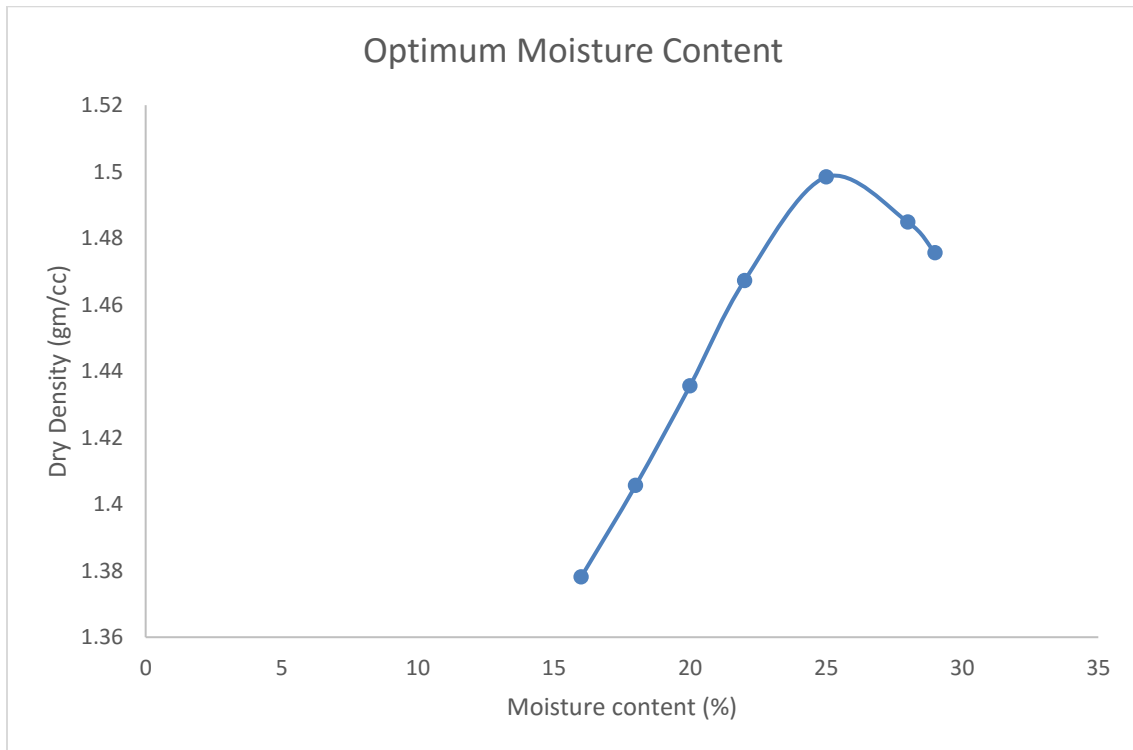

Figure 5.3: Optimum moisture content graph

#### 5.2.4 Direct Shear Test:

Shear strength of a soil is its maximum resistance to shearing stresses and is calculated by conducting Direct Shear Test on the soil specimen. The test shows that the respective values for cohesion and angle of internal friction came out to be  $C=39\text{kN/m}^2$  and  $\Phi=10^\circ$ .

The test is quicker and easier to conduct; however, there may be variations in the shear parameters as it is difficult to draw conclusions regarding shear parameters because of the pseudo cohesion generated due to leachate and also because of the mixed matrix. Figure 5.4 shows the graph between shear stress and time for non-reinforced soil.

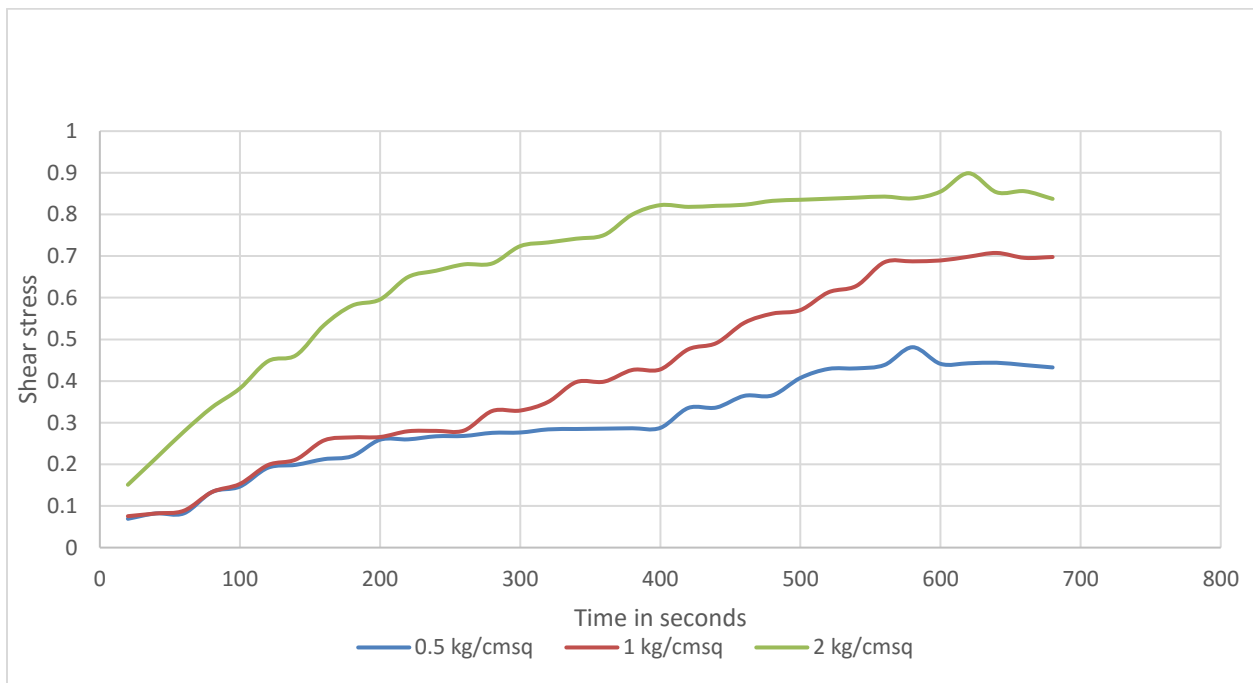

Figure 5.4: Direct shear graph for non-reinforced soil

This graph shows the different peak failure of soil samples with applying different loads i.e. 0.5, 1 and 2 KG/sqcm, further detailed values are given in Annexure. Figure 5.5 shows the graph between normal stress and shear stress for non-reinforced soil.

The value of cohesion and angle of internal friction came out to be  $C=39\text{kN/m}^2$  and  $\Phi=10^\circ$ .

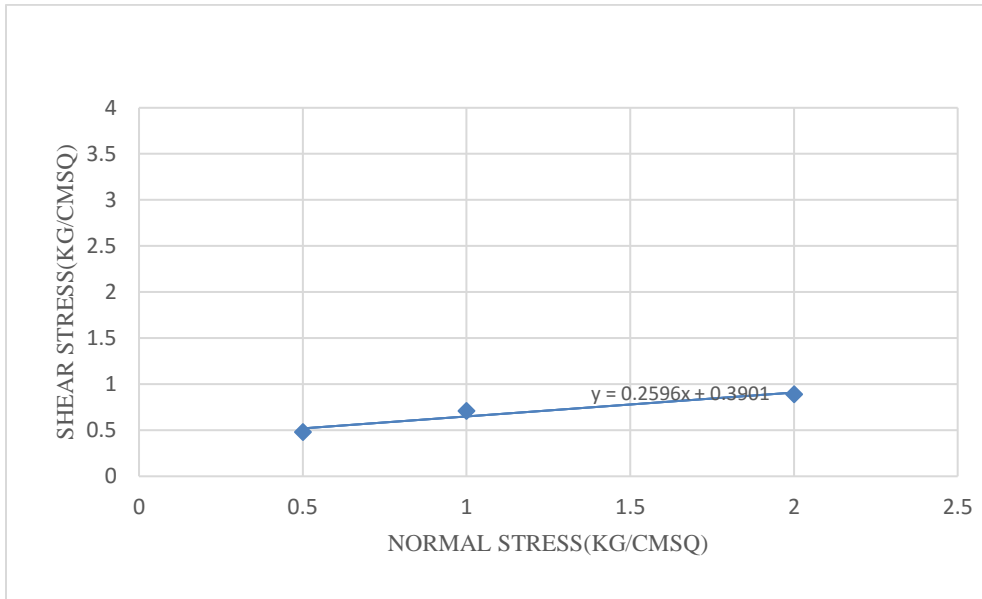

Figure 5.5: Direct shear graph on non-reinforced soil.

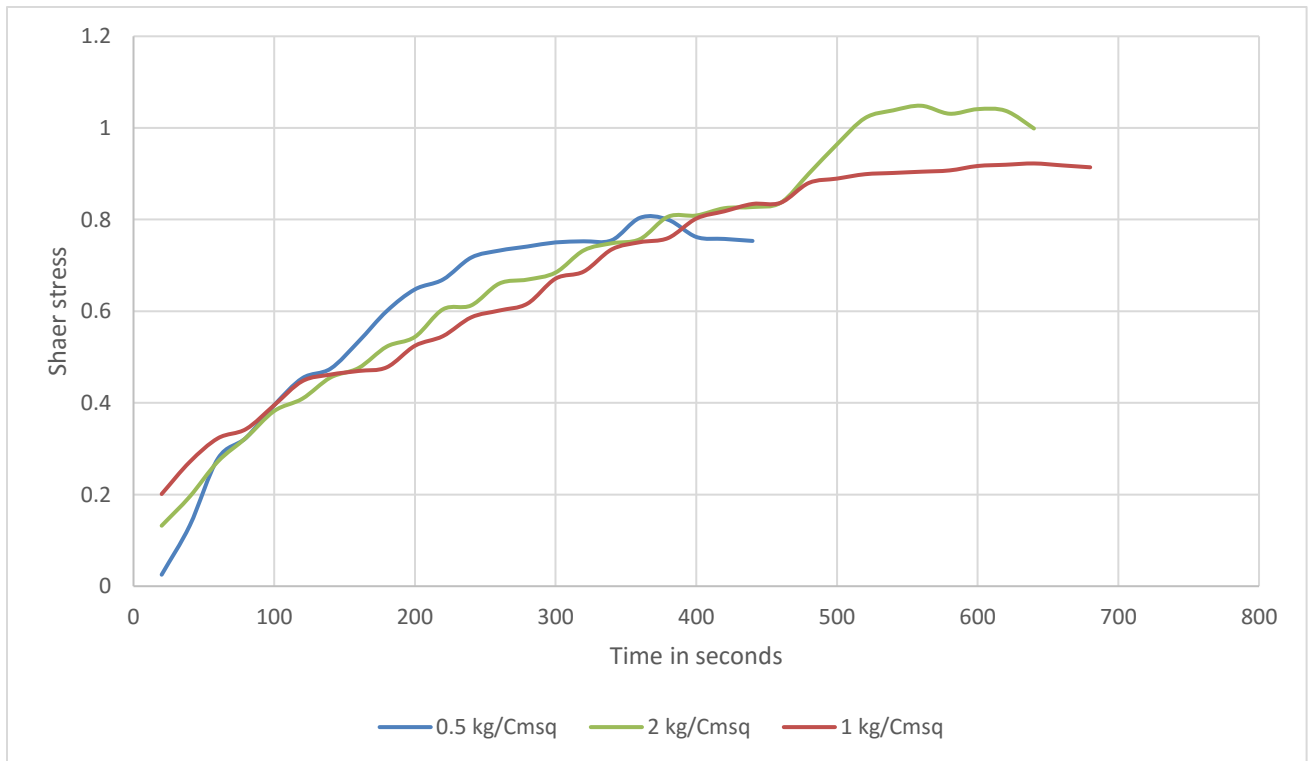

Figure 5.6: Direct shear test on soil with single layer of reinforcement

Graph showing peak variation with using single layer of geotextile with applying different loads i.e. 0.5,1 and 2 kg/sqcm (Refer annexures for detailed values).On further testing of soil sample with single layer of geotextile the respective values for cohesion and angle of internal friction came out to be  $C=74\text{kN/m}^2$  and  $\Phi=7.18^\circ$ . Figure 5.6 shows the graph between shear stress and time for soil with single layer reinforcement and Figure 5.7 shows the graph between normal stress and shear stress for soil with single layer reinforcement.

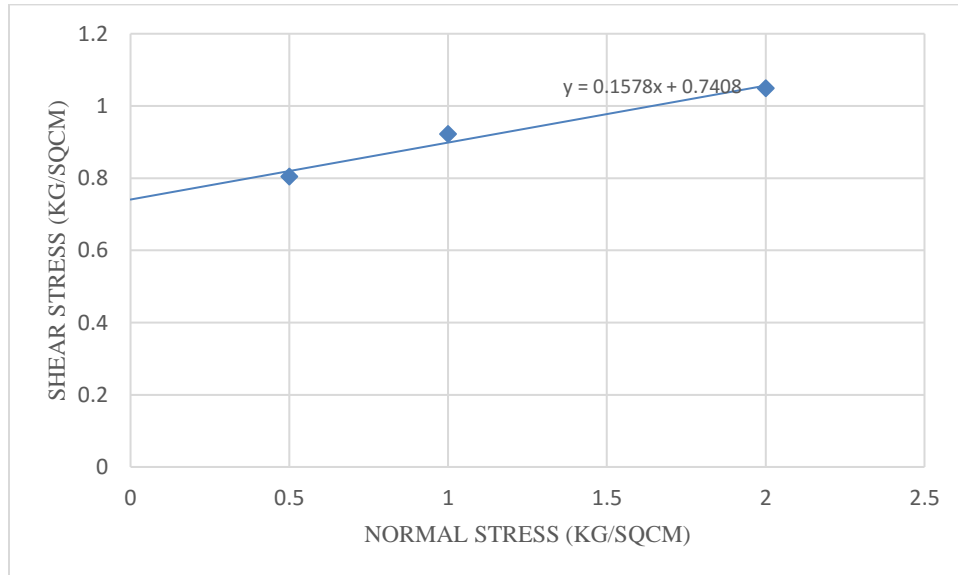

Figure 5.7: Direct shear test on soil with single layer of reinforcement

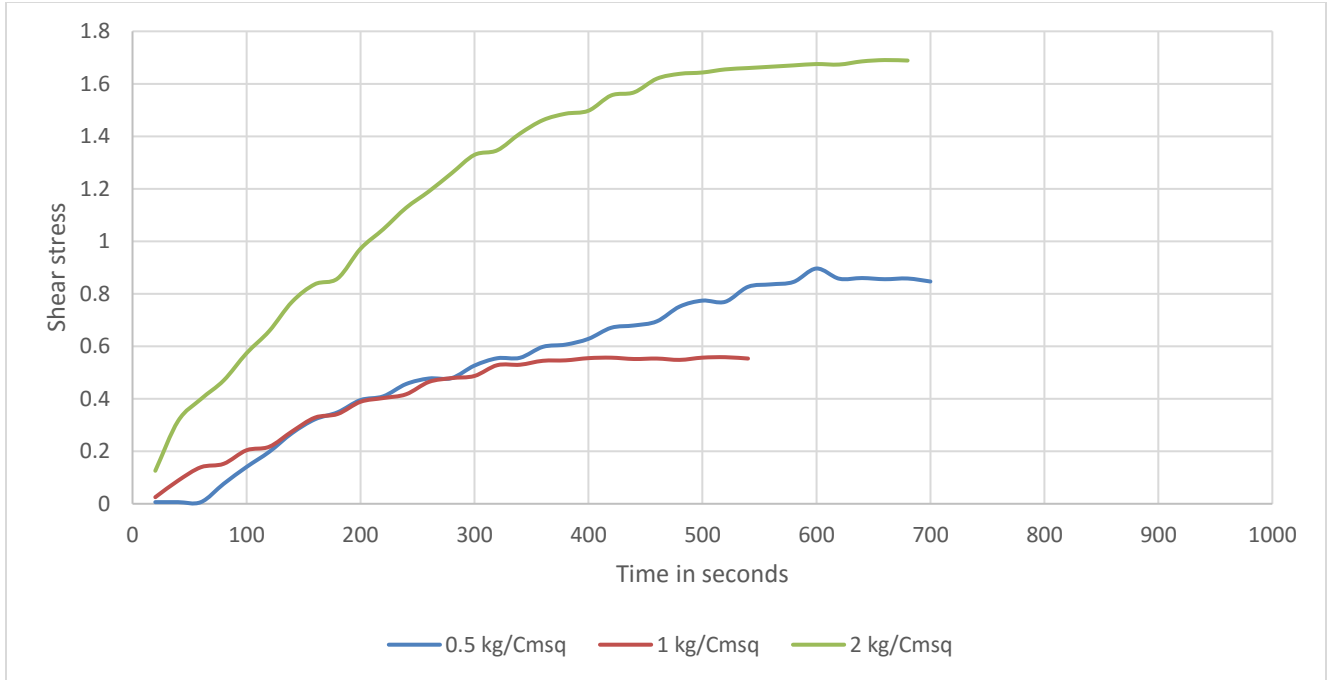

Figure 5.8: Direct shear test on soil with double layer of reinforcement

In figure 5.8 graph shows peak variation with using single layer of geotextile. (Refer annexures for detailed values).

On comparing all three graphs we can conclude that shear stress increases with layer of geotextile.

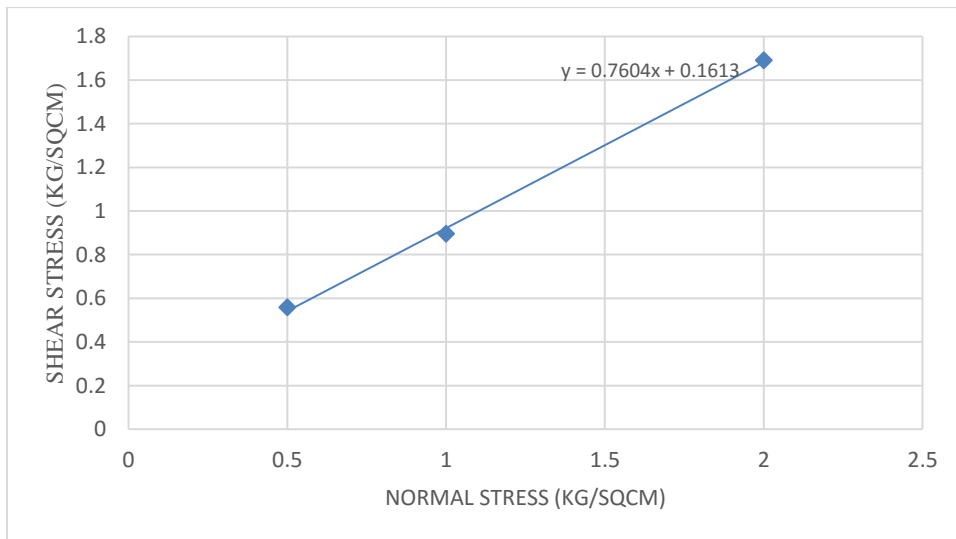

Figure 5.9: Direct shear test on soil with double layer of reinforcement



Now on testing the soil sample with two layer of geotextile values for cohesion and angle of internal friction came out to be  $C=16\text{kN/m}^2$  and  $\Phi=38.30$ . Figure 5.9 shows the graph between normal stress and shear stress for soil with double layer reinforcement.

This shows that angle of internal friction increases with double layer of geotextile which increases the frictional forces in Municipal solid waste soil sample.

Further, calculating the direct shear strength of all the three cases by using the formulae

$$\text{Direct shear strength} = C + \sigma(\tan\phi)$$

Case	Cohesion(c)	Angle of friction( $\phi$ )	Shear strength(kN/sqm)
Without reinforcement	39	10	75.51
Reinforced with one layer of geotextile at H/2	74	7	99.2
Reinforced with two layer at H/3 and 2H/3	16	38	175.85

From the above table we can conclude that with increase in geotextile layer the direct shear strength of soil sample increases. Thus geotextile (geoknit) can be used to increase the shear capacity of the Municipal solid waste soil.

#### 5.2.5 Free Swell Index:

Free swell is the increase in volume of a soil, without any external constraints, on submergence in water. Free Soil Index came out to be **18%** for this soil which indicates very low change in volume of soil under effect of water.

The possibility of damage to structures due to swelling is low since it comes under the range of low expansive soil (<20%). Change in volume of soil may also be caused due to presence of soluble salts in the soil hence the quantity of important salts such as Sulphates, Chlorides may be carried out separately.

## CHAPTER 6

### SUMMARY AND CONCLUSION

#### 6.1 Direct Shear Test:

From the above calculation we can conclude that when we increase the geotextile layer in the Municipal solid waste soil sample the direct shear strength of the soil increases.

Case	Cohesion(c)	Angle of friction( $\phi$ )	Shear strength(kN/sqm)
Without reinforcement	39	10	75.51
Reinforced with one layer of geotextile at H/2	74	7	99.2
Reinforced with two layer at H/3 and 2H/3	16	38	175.85

#### 6.2 Compaction:

The Modified Proctor Test was carried out on this soil since it contained larger sized particles (sand) which requires higher compaction effort for breaking into smaller particles, filling up the voids and causing proper compaction. The test resulted in a **maximum dry density** of **11.75kN/sqm** and the **optimum moisture content** of **25%**.

## REFERENCES

- [1] S.M. Haeri R. Noorzadi A.M. Oskoorouchi (2000). "Effect of geotextile reinforcement on the mechanical behaviour of sand" American Society of Highway Engineers, featured 2012
- [2] R. Noorzad, S.H. Mirmoradi (2009). "Laboratory evaluation of the behaviour of a geotextile reinforced clay" Center for Local Government Technology, Oklahoma State University
- [3] I. Hosseinpour 1, S. H. Mirmoradi1, A. Barari 2, M. Omidvar (2010). "Numerical evaluation of sample size effect on the stress-strain behaviour of geotextile-reinforced sand" International Journal of Science and Research (IJSR)
- [4] Sohrab Iieshmati(1993). "The action of geotextiles in providing combined drainage and reinforcement to cohesive soil" Technical Journal of Indian Chapter of International Geosynthetics Society
- [5] Holtz, R. D. (1975) "Recent developments in reinforced earth", Proc. Seventh Scand. Geotechnical Meeting.
- [6] Barry R. Christopher, "Load Stress on geotextiles" Tamkang Journal of Science and Engineering, Vol. 14
- [7] Holtz, R. D. (1975) "Recent developments in reinforced earth", Proc. Seventh Scand. Geotechnical Meeting.
- [8] Vidal, H (1978)"The Development and Future of Reinforced Earth" International Journal of Civil Engineerng. Vol. 5, No. 4, December 2007
- [9] Richard J. Bathurst, "The principal of Reinforced Earth", International Geosynthetics Society (IGS)
- [10] Dahmen Joe, "Geogrid and high strength woven geotextiles application", GeoEngineeringPDH.
- [11] Gregory, R. N., Barry, C. R., "Triaxle Compression Test for Undisturbed Soils", Calstate fuller tone, Civil and Environmental engineering department

[12]Dry Sean Rees,” General set-up of a soil specimen inside a triaxial cell”, GDS website  
www.gdsinstruments.com

[13]Simon J. Blott and Kenneth Pye “Grain Size Distributions and Soil Particle Characteristics”,  
Surface Processes and Modern Environments Research Group, Department of Geology

[14] Jorge G. Zornberg Test Method and Discussion for the Particle Size Analysis of Soils”,  
Geotechnical Engineering Bureau April 2007

[15]Nurses Kurucuk, Jayantha Kodikara, Delwyn Fredlund, “Prediction of compaction curves”,  
National Academy of science-National Research Council, Washington DC, 1962

[16] Andrew L and Bassett, Paper Archives & Special Collections, Columbia University Health  
Sciences Library C. Andrew.

[17] Madhavi G. Latha and Vidya S. Murthy, International Conference on geotechniques for  
infrastructure projects.

## ANNEXURE

### Annexure A: Particle size distribution

Serial Number	Sieve size	Mass of soil retained(g)	Percentage Retained of each sieve Ru(%)	Cumulative Percentage retained $\Sigma Ru$	Percentage finer 100- $\Sigma Ru$
1	0.425	800	80	80	20
2	0.300	20	2	82	18
3	0.150	110	11	93	7
4	0.075	40	4	97	3
5	Pan	30	3	100	0

## Annexure B: Specific Gravity by Pycnometer

<b>Weight of empty bottle with stopper (W1)</b>	W1=460.9 gms
<b>Weight of bottle and dry soil (W2)</b>	W2 =559.0 gms
<b>Weight of bottle, dry soil and water (W3)</b>	W3 =1301.3 gms
<b>Weight of bottle and water (W4)</b>	W4 =1251.1 gms

$$\text{Sp. Gravity}(G_s) = \frac{(w_2 - w_1)}{(w_2 - w_1) - (w_3 - w_4)}$$

$$\text{Specific gravity of soil} = (559 - 460.9) / (559 - 460.9) - (1301.3 - 1251.1)$$

$$= 2.04$$

## Annexure C: Specific Gravity by Density bottle

Weight of empty bottle with stopper (W1)	W1= 30.10gms
Weight of bottle and dry soil (W2)	W2 =39.90 gms
Weight of bottle, dry soil and water (W3)	W3 =85.20 gms
Weight of bottle and water (W4)	W4 =79.60 gms

$$\text{Sp. Gravity}(G_s) = \frac{(w_2 - w_1)}{((w_2 - w_1) - (w_3 - w_4))}$$

Specific gravity of soil = **2.12**

## Annexure D: Compaction test

<b>Moisture content (%)</b>	<b>Density(g/cm<sup>3</sup>)</b>	<b>Dry Density(kN/m<sup>3</sup>)</b>
16	1.3781	11.64
18	1.4056	11.68
20	1.4356	11.73
22	1.4672	11.79
25	1.4980	11.75
28	1.4848	11.36
29	1.4756	11.22



## Annexure E: Direct shear test (no layers of reinforcement)

Time	Shear strain	Corrected area	Horizontal distance	0.5kg/cm <sup>2</sup>	1kg/cm <sup>2</sup>	2kg/cm <sup>2</sup>	Shear stress		
20	0.0033333 33	35.880398 7	0.2	1.1	1.2	2.4	0.0691 72	0.0754 61	0.1509 21
40	0.0066666 67	35.761589 4	0.4	1.3	1.3	3.4	0.0820 21	0.0820 21	0.2145 16
60	0.01	35.643564 4	0.6	1.3	1.4	4.4	0.0822 92	0.0886 22	0.2785 28
80	0.0133333 33	35.526315 8	0.8	2.1	2.1	5.3	0.1333 72	0.1333 72	0.3366 07
100	0.0166666 67	35.409836 1	1	2.3	2.4	6	0.1465 55	0.1529 27	0.3823 18
120	0.02	35.294117 6	1.2	3	3.1	7	0.1917 86	0.1981 78	0.4475
140	0.0233333 33	35.179153 1	1.4	3.1	3.3	7.2	0.1988 26	0.2116 53	0.4617 89
160	0.0266666 67	35.064935 1	1.6	3.3	4	8.3	0.2123 43	0.2573 85	0.5340 75
180	0.03	34.951456 3	1.8	3.4	4.1	9	0.2194 88	0.2646 77	0.5809 97
200	0.0333333 33	34.838709 7	2	4	4.1	9.2	0.2590 57	0.2655 33	0.5958 3
220	0.0366666 67	34.726688 1	2.2	4	4.3	10	0.2598 92	0.2793 84	0.6497 31
240	0.04	34.615384 6	2.4	4.1	4.3	10.2	0.2672 46	0.2802 83	0.6648 56
260	0.0433333 33	34.504792 3	2.6	4.1	4.3	10.4	0.2681 03	0.2811 81	0.6800 66
280	0.0466666 67	34.394904 5	2.8	4.2	5	10.4	0.2755 19	0.3279 99	0.6822 38
300	0.05	34.285714 3	3	4.2	5	11	0.2763 97	0.3290 44	0.7238 96
320	0.0533333 33	34.177215 2	3.2	4.3	5.3	11.1	0.2838 76	0.3498 94	0.7327 96
340	0.0566666 67	34.069400 6	3.4	4.3	6	11.2	0.2847 74	0.3973 6	0.7417 38

360	0.06	33.962264 2	3.6	4.3	6	11.3	0.2856 73	0.3986 13	0.7507 21
380	0.0633333 33	33.855799 4	3.8	4.3	6.4	12	0.2865 71	0.4265 24	0.7997 33
400	0.0666666 67	33.75 33.75	4	4.3	6.4	12.3	0.2874 69	0.4278 61	0.8222 96
420	0.07	33.644859 8	4.2	5	7.1	12.2	0.3353 11	0.4761 42	0.8181 59
440	0.0733333 33	33.540372 7	4.4	5	7.3	12.2	0.3363 56	0.4910 8	0.8207 08
460	0.0766666 67	33.436532 5	4.6	5.4	8	12.2	0.3643 92	0.5398 41	0.8232 57
480	0.08	33.333333 3	4.8	5.4	8.3	12.3	0.3655 21	0.5618 19	0.8325 75
500	0.0833333 33	33.230769 2	5	6	8.4	12.3	0.4073 88	0.5703 43	0.8351 44
520	0.0866666 67	33.128834 4	5.2	6.3	9	12.3	0.4290 73	0.6129 62	0.8377 14
540	0.09	33.027522 9	5.4	6.3	9.2	12.3	0.4303 89	0.6285 05	0.8402 84
560	0.0933333 33	32.926829 3	5.6	6.4	10	12.3	0.4385 58	0.6852 47	0.8428 53
580	0.0966666 67	32.826747 7	5.8	7	10	12.2	0.4811 35	0.6873 36	0.8385 5
600	0.1	32.727272 7	6	6.4	10	12.4	0.4412 32	0.6894 25	0.8548 87
620	0.1033333 33	32.628398 8	6.2	6.4	10.1	13	0.4425 69	0.6984 29	0.8989 68
640	0.1066666 67	32.530120 5	6.4	6.4	10.2	12.3	0.4439 06	0.7074 75	0.8531 32
660	0.11	32.432432 4	6.6	6.3	10	12.3	0.4382 86	0.6956 93	0.8557 02
680	0.1133333 33	32.335329 3	6.8	6.2	10	12	0.4326 25	0.6977 82	0.8373 38

## Annexure F: Direct Shear Test (single layer reinforcement)

Time	Shear strain	Corrected area	Horizontal distance				Shear stress		
				0.5kg/cmsq	1kg/cmsq	2kg/cmsq			
20	0.003333333	35.8803987	0.2	0.4	2.1	3.2	0.025154	0.201229	0.132056
40	0.006666667	35.7615894	0.4	2.1	3.1	4.3	0.132495	0.271299	0.195588
60	0.01	35.6435644	0.6	4.4	4.3	5.1	0.278528	0.322839	0.272198
80	0.013333333	35.5263158	0.8	5.1	5.1	5.4	0.323904	0.342958	0.323904
100	0.016666667	35.4098361	1	6.2	6	6.2	0.395061	0.395061	0.382318
120	0.02	35.2941176	1.2	7.1	6.4	7	0.453892	0.4475	0.409142
140	0.023333333	35.1791531	1.4	7.4	7.1	7.2	0.474617	0.461789	0.455376
160	0.026666667	35.0649351	1.6	8.3	7.4	7.3	0.534075	0.469728	0.476163
180	0.03	34.9514563	1.8	9.3	8.1	7.4	0.600364	0.477709	0.522898
200	0.033333333	34.8387097	2	10	8.4	8.1	0.647642	0.52459	0.544019
220	0.036666667	34.7266881	2.2	10.3	9.3	8.4	0.669223	0.545774	0.60425
240	0.04	34.6153846	2.4	11	9.4	9	0.717002	0.586638	0.612711
260	0.043333333	34.5047923	2.6	11.2	10.1	9.2	0.732378	0.601596	0.660448
280	0.046666667	34.3949045	2.8	11.3	10.2	9.4	0.741278	0.616638	0.669118
300	0.05	34.2857143	3	11.4	10.4	10.2	0.75022	0.671249	0.684411
320	0.053333333	34.1772152	3.2	11.4	11.1	10.4	0.752601	0.686584	0.732796
340	0.056666667	34.0694006	3.4	11.4	11.3	11.1	0.754983	0.735115	0.74836
360	0.06	33.9622642	3.6	12.1	11.4	11.3	0.80387	0.750721	0.757365
380	0.063333333	33.8557994	3.8	12	12.1	11.4	0.799733	0.759746	0.806397

400	0.066666667	33.75	4	11.4	12.1	12	0.762128	0.80224	0.808925
420	0.07	33.6448598	4.2	11.3	12.3	12.2	0.757803	0.818159	0.824866
440	0.073333333	33.5403727	4.4	11.2	12.3	12.4	0.753437	0.834162	0.827435
460	0.076666667	33.4365325	4.6		12.4	12.4		0.836753	0.836753
480	0.08	33.3333333	4.8		13.3	13		0.879957	0.900264
500	0.083333333	33.2307692	5		14.2	13.1		0.889463	0.96415
520	0.086666667	33.1288344	5.2		15	13.2		0.89901	1.021603
540	0.09	33.0275229	5.4		15.2	13.2		0.901768	1.038399
560	0.093333333	32.9268293	5.6		15.3	13.2		0.904526	1.048427
580	0.096666667	32.8267477	5.8		15	13.2		0.907283	1.031004
600	0.1	32.7272727	6		15.1	13.3		0.916935	1.041032
620	0.103333333	32.6283988	6.2		15	13.3		0.919714	1.037271
640	0.106666667	32.5301205	6.4		14.4	13.3		0.922492	0.998789
660	0.11	32.4324324	6.6			13.2		0.918314	
680	0.113333333	32.3353293	6.8			13.1		0.914094	

## Annexure G: Direct Shear Test (Double layer reinforcement)

Time	Shear strain	Corrected area	Horizontal distance	0.5kg/cm <sup>2</sup>	1kg/cm <sup>2</sup>	2kg/cm <sup>2</sup>	Shear stress		
20	0.00333333 33	35.880398 7	0.2	0.1	0.4	2	0.006288	0.025154	0.125768
40	0.00666666 67	35.761589 4	0.4	0.1	1.4	5	0.006309	0.08833	0.315464
60	0.01	35.643564 4	0.6	0.1	2.2	6.3	0.00633	0.139264	0.398801
80	0.01333333 33	35.526315 8	0.8	1.2	2.4	7.4	0.076213	0.152426	0.469979
100	0.01666666 67	35.409836 1	1	2.2	3.2	9	0.140183	0.203903	0.573476
120	0.02	35.294117 6	1.2	3.1	3.4	10.3	0.198178	0.217357	0.658464
140	0.02333333 33	35.179153 1	1.4	4.2	4.3	12	0.269377	0.275791	0.769649
160	0.02666666 67	35.064935 1	1.6	5	5.1	13	0.321732	0.328166	0.836502
180	0.03	34.951456 3	1.8	5.4	5.3	13.3	0.348598	0.342143	0.858585
200	0.03333333 33	34.838709 7	2	6.1	6	15	0.395061	0.388585	0.971463
220	0.03666666 67	34.726688 1	2.2	6.3	6.2	16.1	0.40933	0.402833	1.046067
240	0.04	34.615384 6	2.4	7	6.4	17.3	0.456274	0.417165	1.127649

260	0.0433333 33	34.504792 3	2.6	7.3	7.1	18.2	0.4773 54	0.4642 76	1.1901 15
280	0.0466666 67	34.394904 5	2.8	7.3	7.3	19.2	0.4788 79	0.4788 79	1.2595 17
300	0.05	34.285714 3	3	8	7.4	20.2	0.5264 7	0.4869 85	1.3293 37
320	0.0533333 33	34.177215 2	3.2	8.4	8	20.4	0.5545 48	0.5281 41	1.3467 6
340	0.0566666 67	34.069400 6	3.4	8.4	8	21.3	0.5563 03	0.5298 13	1.4106 26
360	0.06	33.962264 2	3.6	9	8.2	22	0.5979 2	0.5447 71	1.4615 81
380	0.0633333 33	33.855799 4	3.8	9.1	8.2	22.3	0.6064 64	0.5464 84	1.4861 7
400	0.0666666 67	33.75	4	9.4	8.3	22.4	0.6284 21	0.5548 83	1.4975 15
420	0.07	33.644859 8	4.2	10	8.3	23.2	0.6706 23	0.5566 17	1.5558 44
440	0.0733333 33	33.540372 7	4.4	10.1	8.2	23.3	0.6794 39	0.5516 24	1.5674 18
460	0.0766666 67	33.436532 5	4.6	10.3	8.2	24	0.6950 45	0.5533 37	1.6195 22
480	0.08	33.333333 3	4.8	11.1	8.1	24.2	0.7513 48	0.5482 81	1.6380 74
500	0.0833333 33	33.230769 2	5	11.4	8.2	24.2	0.7740 36	0.5567 63	1.6431 3
520	0.0866666 67	33.128834 4	5.2	11.3	8.2	24.3	0.7696 07	0.5584 76	1.6549 96
540	0.09	33.027522 9	5.4	12.1	8.1	24.3	0.8266 21	0.5533 58	1.6600 73

560	0.0933333 33	32.926829 3	5.6	12.2		24.3	0.8360 01	1.6651 49
580	0.0966666 67	32.826747 7	5.8	12.3		24.3	0.8454 23	1.6702 26
600	0.1	32.727272 7	6	13		24.3	0.8962 53	1.6753 03
620	0.1033333 33	32.628398 8	6.2	12.4		24.2	0.8574 78	1.6734 64
640	0.1066666 67	32.530120 5	6.4	12.4		24.3	0.8600 68	1.6854 56
660	0.11	32.432432 4	6.6	12.3		24.3	0.8557 02	1.6905 33
680	0.1133333 33	32.335329 3	6.8	12.3		24.2	0.8582 71	1.6886 32
700	0.116667	32.23881	12.1	12.1			0.8468 44	