

IOT BASED TRAFFIC SIGNAL MONITORING AND CONTROLLER

*Project report submitted in partial fulfilment of the requirement for the
degree of*

BACHELOR OF TECHNOLOGY

IN

ELECTRONICS AND COMMUNICATION ENGINEERING

BY

AKHIL CHAUHAN (171005)

UNDER THE GUIDANCE OF

Dr.Nafis Uddin Khan

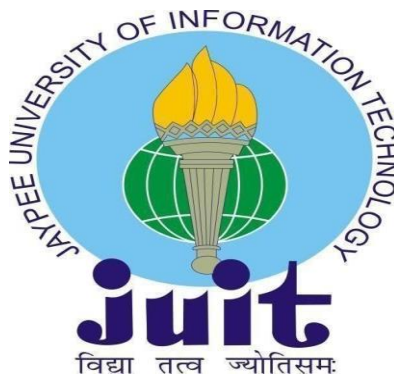

**JAYPEE UNIVERSITY OF
INFORMATIONTECHNOLOGY,WAKNAGHAT**

May ,2021

DECLARATION

I thusly proclaim that the strategy introduced in the B.Tech Report named "IOT BASED TRAFFIC SIGNAL MONITORING AND CONTROLLER" submitted at JAYPEE UNIVERSITY OF INFORMATION, WAKNAGHAT, INDIA is an exact portrayal of our work.

Under the oversight of Dr.Nafis Uddin Khan, the work was finished. This isn't something I've sent.

Work elsewhere in the event that you need to get an alternate degree or confirmation.

AKHIL CHAUHAN

ROLL NO-171005

SIGNATURE-

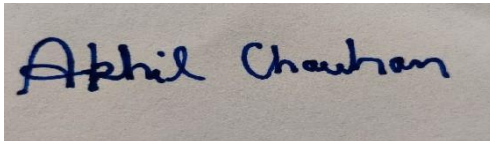
A photograph of a handwritten signature in blue ink on a light-colored surface. The signature reads "Akhil Chauhan".A photograph of a handwritten signature in black ink on a light-colored surface. The signature is a stylized "N" followed by "Uddin Khan".

Dr. Nafis Uddin Khan

(Project Supervisor)

ACKNOWLEDGEMENT

I'd like to thank my Supervisor, Dr.Nafis Uddin Khan, for always being a source of motivation and support during my project work. His wilfulness and experience have taught me important life lessons that will be extremely useful in making choices in the future. In addition, I might want to offer my thanks to the entirety of the educating and non-instructing staff for their guidance throughout this project.

ABSTRACT

In this project, we propose an IoT-based robotized traffic light monitoring and regulation system that computerises complete traffic flagging framework computerization while also considering manual abrogate over the internet. The framework uses an arduino-based circuit framework to screen traffic light densities and sends the data to the regulators through the internet. IOTGecko is a tool that we use to create websites. The system depicts existing densities in order to aid in the screening of traffic patterns on city streets. Furthermore, the system allows regulators to remove any sign and turn it green if a rescue vehicle or significant vehicle is present, while keeping other signs red. This advances a system for traffic light checking and regulation that can be sorted out.

TABLE OF CONTENTS

CHAPTER NO.	TITLE	PAGE NO.
	DECLARATION	2
	ACKNOWLEDGEMENT	3
	ABSTRACT	4
	LIST OF FIGURES	7
	LIST OF ABBREVIATIONS	8
1	INTRODUCTION	
	1.1 Speculation	9
	1.2 Motivation	9
2	LITERATURE REVIEW	
	2.1 About IoT	10
	2.2 Advantages and Disadvantages of IoT	10
	2.2.1 Advantages	10
	2.2.2 Disadvantages	11
	2.3 IoT in Track Management	12
3	REQUIREMENTS	

	3.1 Hardware Components	13
	3.2 Software Requirement	16
4	PRINCIPLE	
	4.1 Existing System	18
	4.1.1 Disadvantages of Existing System	18
	4.2 Proposed System	18
	4.2.2 Advantages of Proposed System	19
	4.3 Method	19
	4.3.1 View of Signals at Different Lanes	20
	4.4 Diagrams	22
	4.4.1 Flow Chart	22
	4.4.2 Sequence Diagram	23
	4.4.3 Use Case Diagram	24
	4.5 Algorithms	25
	4.5.1 Vehicle Counter Algorithm	25
	4.5.2 Trac Control Algorithm	25
5	RESULTS AND ANALYSIS	
	5.1 Results and Analysis	27
	5.2 Challenges	28
6	CONCLUSION AND FUTURE SCOPE	
	6.1 Conclusion	29
	6.2 Future Scope	29

REFERENCES

LIST OF FIGURES

FIGURE N	TITLE	PAGE N
O		O
3.1	Arduino Mega 2560	13
3.2	Arduino UNO	14
3.3	LED for Traffic Lights	14
3.4	IR Sensors	15
3.5	Jumper Wires	15
3.6	Wi-Fi Module	16
3.7	Ultrasonic Sensor	16
4.1	Control of Previous Intersection	20
4.2	Signal at Lane 1	20
4.3	Signal at Lane 2	21
4.4	Signal at Lane 3	21
4.5	Flow Chart	22
4.6	Sequence Diagram	23
4.7	Use Case Diagram	24
5.1	Model of the Project	27

LIST OF ABBREVIATIONS

IoT	Internet of Things
ITS	Intelligent Transportation System
LED	Light Emitting Diode
Wi-Fi	Fidelity
WSN	Wireless Sensor Network
NFC	Near Field Communication

CHAPTER 1

INTRODUCTION

1.1 Speculation

To keep traffic flowing running all the more easily, a shrewd traffic the board framework dependent on sensor information, correspondence, and mechanized calculations is being made. The design is to save the hour of green or red light for a specific traffic light at a convergence as effectively as could really be expected. The traffic signs ought not generally be a similar shade of green or red, yet ought to differ contingent upon the quantity of vehicles out and about. When traffic was that he was he

1.2 Motivation

In 2014, urban dwellers made up 54 percent of the global population. The forecast was for annual growth of approximately 2% until 2020, putting more strain on cities' transportation systems. Furthermore, the huge expenditure of living in business districts causes cityworkers to live far away from their places of work/study, requiring them to commute back and forth.

CHAPTER 2

LITERATURE REVIEW

2.1 ABOUT IoT

The Internet of Things (IoT), in any case called the Internet of Everything (IoE), is involved all web-enabled devices that usage embedded sensors, processors, and correspondence gear to get, convey, and circle back to data from their ecological variables. These "associated" or "splendid" contraptions may habitually talk with other near devices, a communication known as "disseminated registering." Humans can interact with the devices to build them up, deliver them headings, and access data, but really the devices do the majority of the work. The whole of the tiny versatile portions opens today, similarly as the reliably online nature of our home and business associations, have enabled their world. Related contraptions consistently produce a lot of data, similarly as a bounty of data that can be burrowed for an arrangement of purposes just as making the devices accommodating. The aggregate of this new information, gotten together with the devices' ability to connect with the Internet, presents insurance and security issues. Regardless, this development outfits us with We've never ever had a high degree of consistency in data before. We could keep a keen eye on our homes and families in an indirect reason to maintain them secure. Associations should redesign their cycles to help adequacy while cutting down material waste and unconstrained excursion. City system sensors can help reduce gridlock and alert us when establishment is in danger of falling. Outside contraptions will follow changing normal conditions and alert us to certain disasters.

2.2 Advantages and Disadvantages of IoT

2.2.1 Advantages

1 Connectivity: The Internet of Things works with PC correspondence, in any case called Machine-to-Machine (M2M) correspondence. Consequently, real contraptions can remain associated, achieving total straightforwardness with lower anomalies and higher capability

.2 Automation and Control: There is a huge load of robotization and control in the procedure in light of the fact that real articles are getting associated and supervised cautiously and part of the way through distant associations. Machines can speak with each other without human block, achieving faster and even more helpful creation.

3 Data: It renounces the logic that possessing more data helps to make better decisions. Communication is key, and more information is more valuable, be it for making actions like what to purchase at the market and determining whether your company has enough contraptions and resources... Furthermore, monitoring your back end of things may and will increase protection.

4 Tracking: The next most obvious benefit of IoT is monitoring. Determining measure for arrangements or the environmental impact in the household may provide you with previously unseen information. Understanding you're from out milk or ink cartridges, for example, will help you avoid rushing to the shop. Checking when things end is also crucial.

5 Time: Shown in earlier models, total duration of effort avoided by using the Internet of Things could be enormous. Furthermore, throughout today's world, it might all benefit from more energy.

6 Income: This opportunity to save money is the primary advantage of IoT. If the cost of labelling and storing data was lower, the Internet of Things will be widely adopted. GPS signals isn't by and large the proportion of money saved. IoT altogether benefits people in their customary day by day presences by allowing mechanical assemblies to speak with one another in a gainful manner, thusly saving and checking energy, and cost. Allowing the data to be passed on and split between devices and a short time later making an understanding of it into our important way, it makes our systems efficient.

7 Efficient and productive: Since machine-to-machine correspondence is more compelling, strong results can be made even more quickly. In this way, important time is saved. It grants people to do other charming situations rather than reiterating comparable tasks reliably.

2.2.2 Disadvantages

1 Compatibility: There is at present no worldwide standard for stepping and following equipment closeness. This is, from my perspective, the least difficult downside to endure. These equipment's producers essentially need to pick an arrangement, as Bluetooth or USB. There's no necessity for something current or essential here.

2 Complexity: As in any unpredictable structure, there is a higher peril of dissatisfaction. Disillusionments could take off due to the Internet of Things (IoT) is a term that refer Assume you and your friend both receive notification that your milk supply is running out, and you both stop at a store on your way home to get some. As a result, you and your companion have purchased twice as much as you require. Or then again even an item botch makes your printer demand another ink cartridge reliably a few days, or if nothing else after every power outage, when you simply need a singular replacement.

3. Data protection: As the more Internet of things information is transmitted, the risk of assurance getting hacked increases. How well will the data be kept and sent mixed, for example? Do you need any neighbours or managers who know what medications you're taking as well as how much resources users have?

4. Security: Since every single homegrown gadget, current stuff, public territory organizations, for instance, water supply and transportation, and a combination of various devices are associated with the Internet, there is a wealth of data available. Developers are likely going to zero in on this material. It would be disastrous if unapproved intruders got to private and characterized information.

5. Lower Manpower Employment: on account of the computerization of step by step assignments, clumsy trained professionals and partners can lose their positions. This will achieve social joblessness issues. This is an issue that arises with the introduction of any advancement and can be tended to via preparing. Ordinarily, as consistently undertakings become more automated, there will be less demands on HR, especially delegates and less taught individuals. This will achieve a social joblessness issue.

2.3 IoT in Track Management

Conceivably the fundamental advancement challenges facing farming countries today is track the leaders. Made countries and clever metropolitan networks are as of now using IoT for their potential benefit to diminish trac issues. People in a wide scope of countries have quickly fostered a vehicle culture. People in numerous metropolitan networks will overall

drive their own vehicles, paying little brain to how extraordinary or defenceless open travel is or what measure of time and money it would need to get to their target.

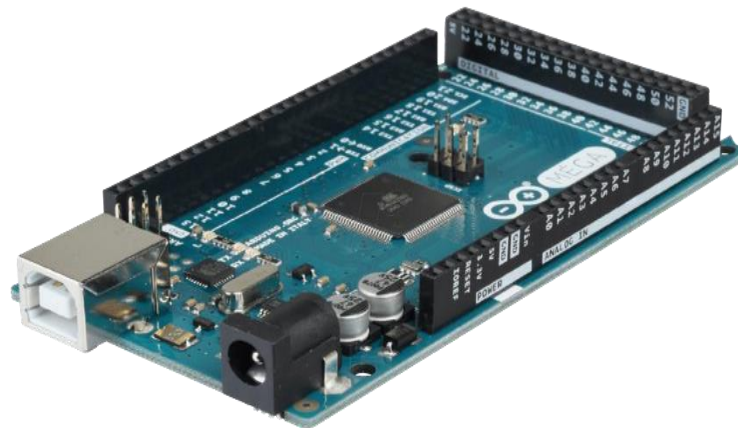

CHAPTER 3

REQUIREMENTS

3.1 Hardware Components

1. **Microcontroller (Arduino Mega 2560)**- is a microcontroller board is based on the ATmega2560 microcontroller. That has 54 mechanical data/yield pins (15 of which can be used as PWM yields), 16 simple data wellsprings, 4 UARTs (hardware sequential ports), a 16 MHz diamond oscillator, a USB affiliation, a power jack, an ICSP header, and a reset button. It does everything necessary to assist a microcontroller; to begin, attach it to a PC through USB or power it with an AC-to-DC connector or battery. Most shields required for the Uno and previous sheets Duemilanove or Diecimila are realistic on the Mega 2560 board. The Arduino Mega 2560 is a successor to the Arduino Mega..

Figure 3.1 Arduino Mega 2560

2. Microcontroller (Arduino Uno):

with simple hardware and Arduino sheets may light from a touch on a

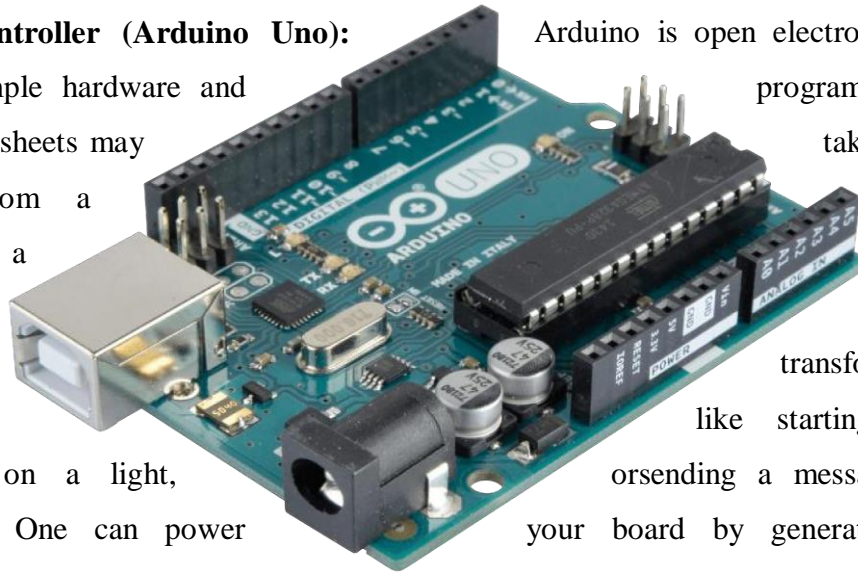

Arduino is open electronics platform programming.

take inputs like sensor, a grab, or message or

transform them into

like starting a motor,

orsending a message over the

your board by generating a large

number of bearings to the board's micro – controller.To use it, you'll need the

outputs

turning on a light,

internet. One can power

number of bearings to the board's

Arduino software (which includes Wiring) and the Arduino Software (IDE), which includes Processing data and can be of great assistance to both students and experts.

Arduino has been the brain behind thousandsof projects over the years, ranging from simple household items to sophisticated smart instruments.

Figure 3.2: Arduino Uno

3. LEDs: LEDs are being used to signal the trac basis of these factors on the trac position.



Figure 3.3: LED For Traffic Lights

4. **IR Sensor:** IR Sensor is a sort of sensor that can detect objects inside the scope of 15cm

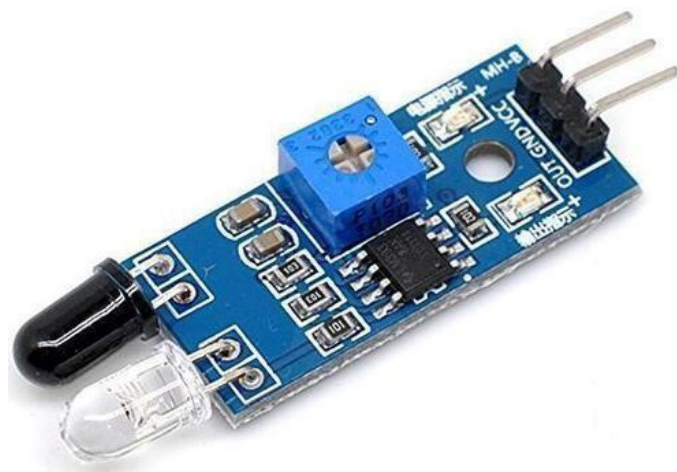

to 50cms.

Figure 3.4: IR Sensors

5. **JumperWires:** It was used to link the different components together.

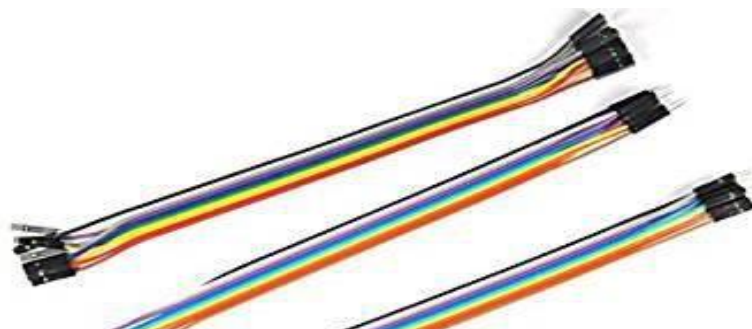

Figure 3.5: Jumper Wires

6. **Wi Fi Module:**The microcontroller's computed data is then transmitted to a local server via Wi-Fi connectivity.

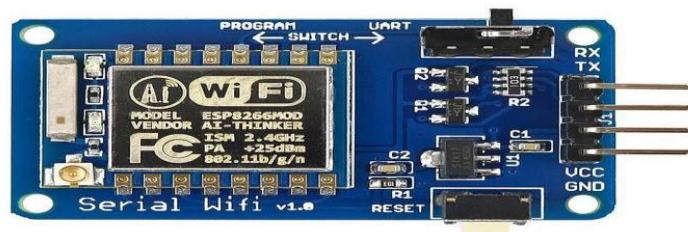

Figure 3.6: Wi Fi module

7. **Ultrasonic Sensor:**The sensors are ultrasonic sensors that relay information based on the proximity of a vehicle.



Figure 3.7 : Ultrasonic Sensor

3.2 Software Requirement

1. **Arduino IDE:** The Arduino IDE is a Java-based guided enhancement environment. stage-crossing framework that unexpected spikes popular for Windows, Mac OS X, and Linux. It's used to program the Arduino board and move them.

The IDE's source code is available under the GNU General Public License, variation .

The Arduino IDE uses remarkable code sorting out rules to help the vernaculars C and C++.

The Wiring project fuses an item library that is joined with the Arduino IDE and gives a couple of standard information and yield procedure.

- Setup(): a limit run once toward the beginning of a program that can intake settings
- Loop(): a limit brought again and again until the board control off.

Open the ArduinoIDE programming and select the board being utilized. For picking the board, follow these instructions:

- Go to the Tools menu.
- Select Committee
- Select the board that is currently being used, in this case Arduino UNO, under board.
- Select the port to which the Arduino board is connected from the Tools and Port menus.

The main assisted situation of the Arduino advancement is that we can simply heap a assignment in into gadgets despite requiring any equipment designer must absorb the software. This is due to the 0.5KB boot loader's design, which allows the software to be unloaded into the circuit. So, it includes a material manager (which is used to organise the content), a message area (shows feedback) such as displaying errors, a material support, which displays the o/p, and a progression in categories such as the log, mechanical get-together menu, and change.

2. Proteus Design Suite: The Proteus Design Suite is a device suite which limits programming. that is predominantly used to computerize electronic plan. Electronic plan architects and specialists utilize the program to create schematics and electronic prints for printed circuit board producing.

CHAPTER 4

PRINCIPLE

4.1 Existing System

The traffic police are liable for the current traffic plot. The best shortcoming of this traffic police-controlled contraption is that it is unequipped for overseeing traffic blockage. The traffic cop has the decision of either impeding a road for a more expanded time span or allowing automobiles on different path to drive the dynamic may not have been sufficient sharp and it by and large based on the judgement of the social. The unique cycle most likely will not be just probably as cunning as it should be, and it is totally dependent upon the social's decision. Moreover, in like manner with traffic lights, the time interval for which the vehicles will give a green or red indication is fixed. In this way, it likely will not have the choice to handle the traffic obstruct issue. Within India, these have been observed that traffic police officers continue to operate despite the existence of traffic lights, implying that this device needs more work and is inefficient in nature.

4.1.1 Disadvantages of Existing System

- i) Obstruction in the train tracks
- ii) There is no way to detect Obstruction
- iii) The number of incidents is higher
- iv) It cannot be monitored faraway
- v) It takes more power

vi) it can be low cost effective

4.2 Proposed System

The far-off sensor center points, which are included sensors, are the structure's first and most critical section. The sensors talk with the genuine world, similar to the presence or nonattendance of vehicles, and the data from the sensors is transported off the central microcontroller by the local labourer. In each way, this contraption uses a 4*2 group of sensor centers. This implies four Trac levels and two ways toward each way. The sensors are ultrasonic sensors that hand-off information reliant upon the closeness of a vehicle. The sensor centers send data to a central microcontroller situated at each intersection point at predestined stretches. The sign is gotten by the microcontroller, which discovers which road and which way should be picked subject to the thickness of Trac The Microcontroller's figured data is then shipped off a local laborer through Wi-Fi accessibility. The data got by the controller is used by the controller to play out the Intelligent Trac coordinating. The fundamental goal of this structure is to gather information from moving vehicles using WSN to give them a quick route to their complaints, and trac signs can turn. to give them a clear a path till their protests and trac signs should switch subsequently to give a sensible way.

4.2.2 Advantages of Proposed System

- i) Reduces the number of hazards
- ii) Saves time & money by lowering fuel costs.
- iii) Limited financial resources.
- iv) Ease of implementation and upkeep
- v) It can be managed from a distance.
- vi) Reduces the time and expense of commuting.

4.3 Method

The trac lights in this contraption LEDs have been used, and the system is checking an ultrasonic sensor is a device that detects sound waves. Real wires interface the two dots to the Microcontroller. The trac light controller is a microcontroller that gets sensor data and controls the trac lights by trading between green, yellow, and red. Taking into account the distances controlled The Microcontroller measures the number of vehicles in the street of the combination using the ultrasonic sensor and the situation between those assessments. monitoring. The successive port on the microcontroller is used for this correspondence. The data gained by the local specialist is exchanged with the cloud laborer to all the almost certain expect changes in trac light timings. Wi-Fi is used for this correspondence. The cloud

specialist, explicitly, uses a condition that takes the data procured (number of vehicles) as information and figures the time span needed for a smooth follow ow. This intentional time is then stood out from the current LEDs' ceaseless (data is taken care of in an informational collection). on a cloud-based specialist). Starting there ahead, the laborer makes a decision. If the current authentic green time isn't actually the intentional time, the green time will be extended; something different, the green time will be decreased. (K Chandana, 2013)

4.3.1A View of signals at different Lanes

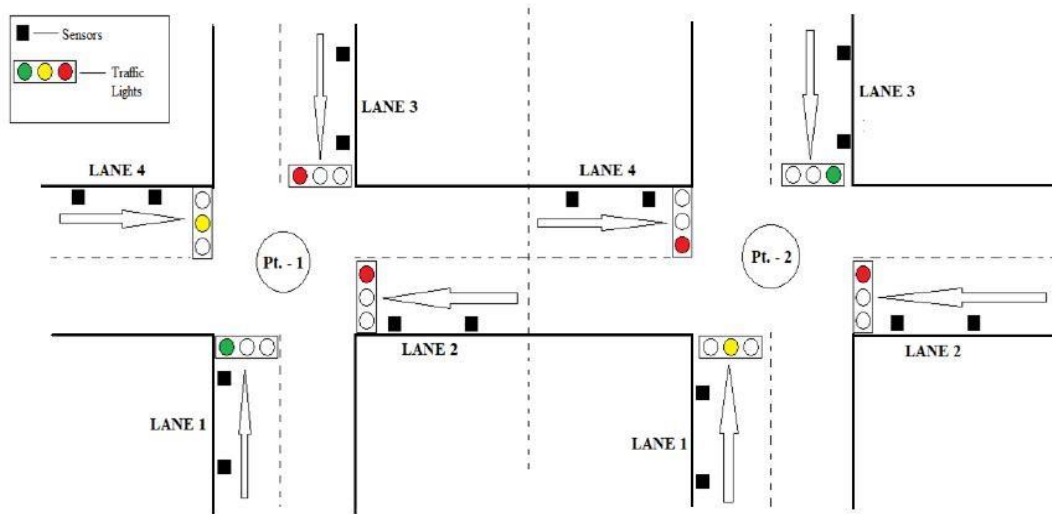

Figure4.1:Control of previous instruction

Path 1 is right now open with a green sign in Pt. - 1, and Lane 4 is prepared with a yellow sign, however Lane 2 and Lane 3 are impeded. Since the quantity of vehicles in LANE 3 surpasses the edge esteem, the way prompting Lane 2 of Pt-1 obstructed in Pt. - 2. Thus, they are rerouted into various paths. (Expecting the current crossing point is Pt. - 1)

Pt- 2 (is the previous intersection.)

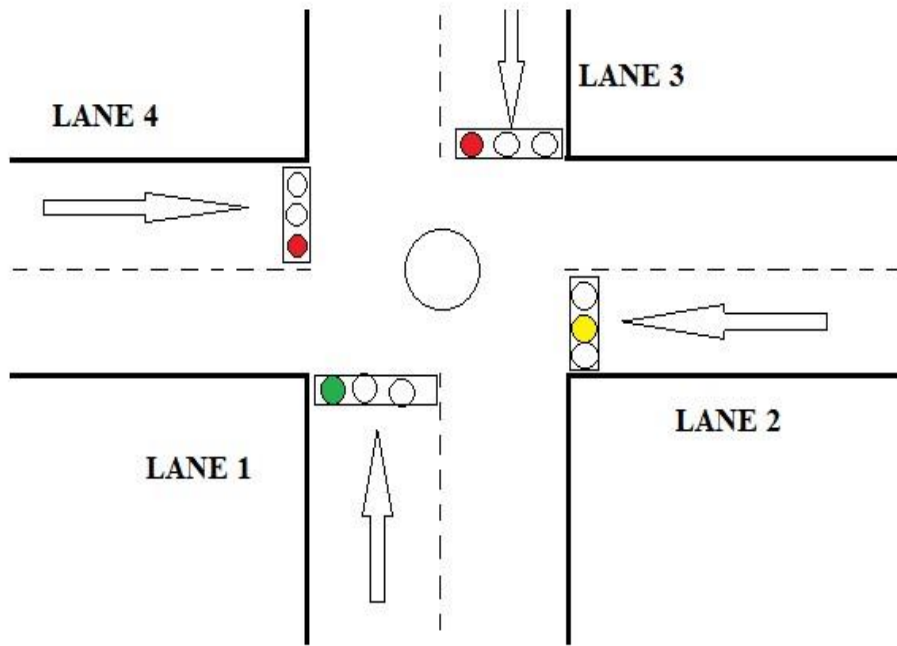

Figure 4.2: Signal at Lane 1

Lane 1 is open with a green signal, while the other lanes are closed with a red signal.

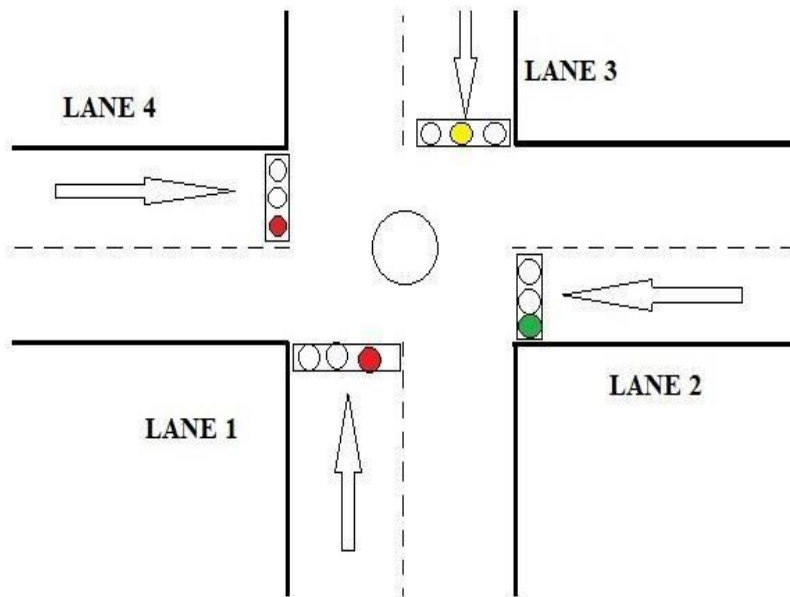

Figure 4.3: Signal at Lane 2

Lane 2 is open with a green signal, while the other lanes are closed with a red signal in the diagram above.

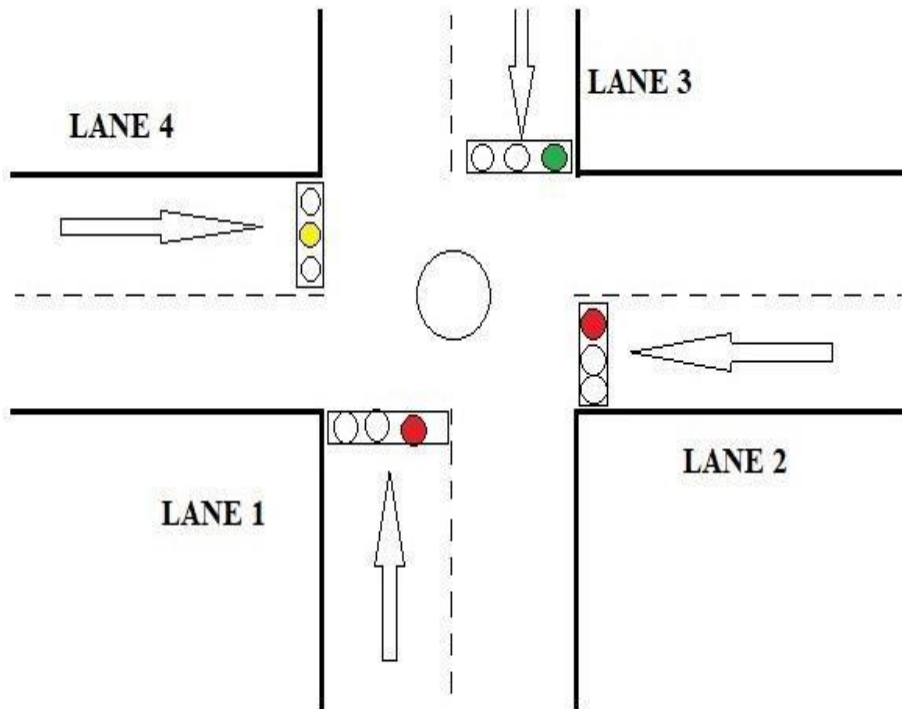

Figure 4.4 :Signal at Lane 3

Lane 3 is unguarded with a green sign, while other paths are closed with a red sign, and Lane 4 will automatically receive the green sign.

4.4 Diagrams

4.4.1 Flowchart

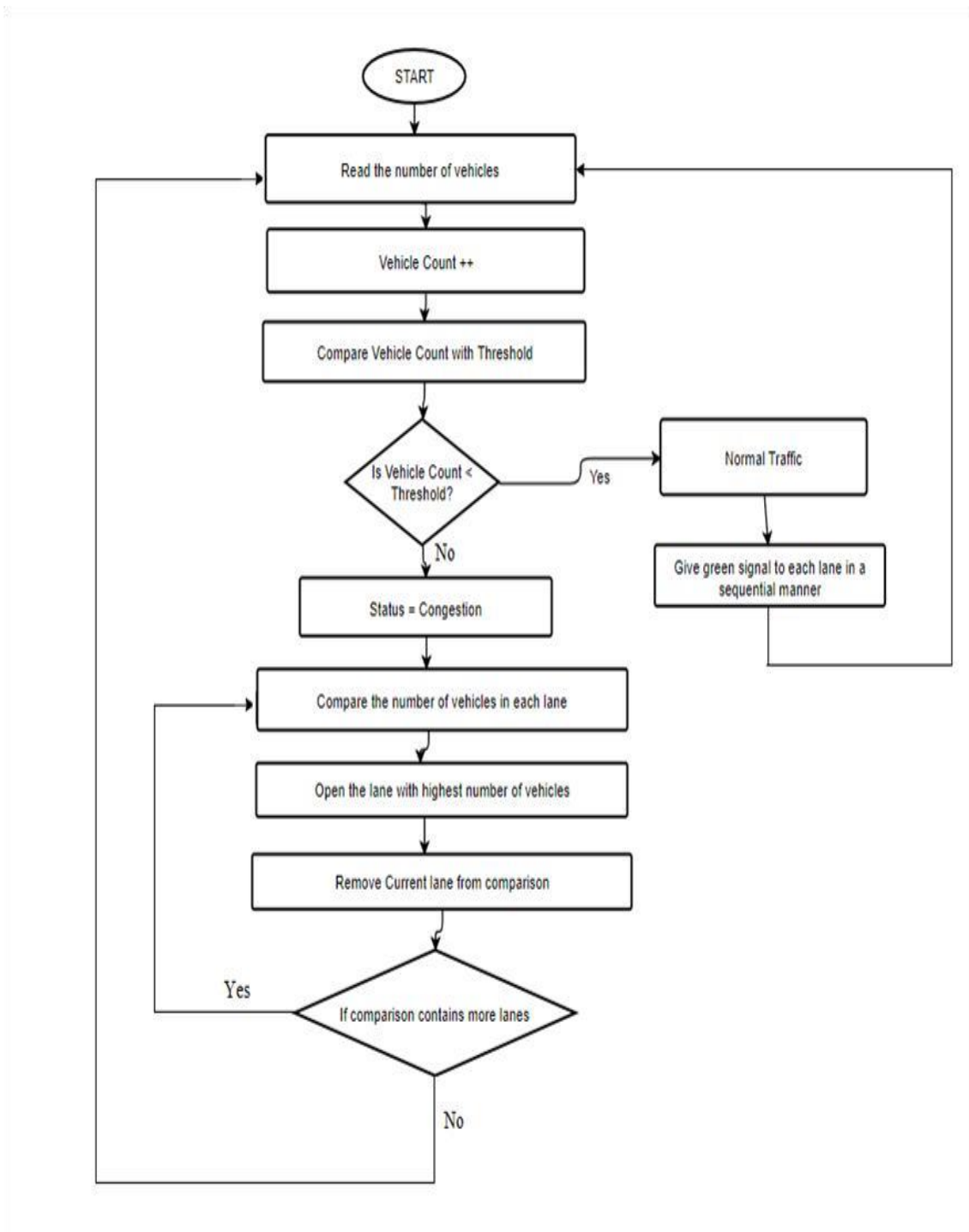

Figure 4.5 Flowchart

4.4.2 Sequence Diagram

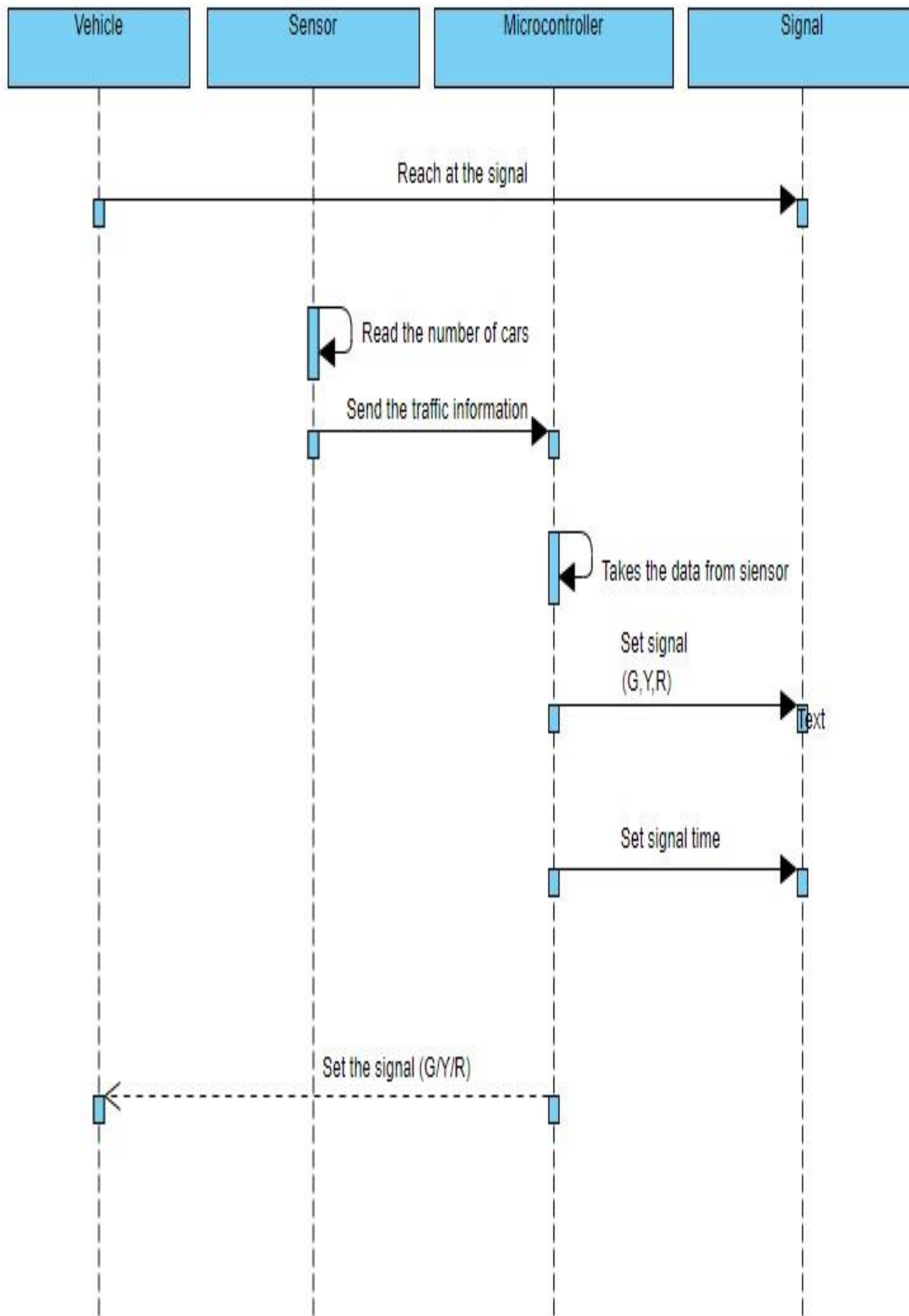

Figure 4.6: Sequence Diagram

4.4.3 Use Case Diagram

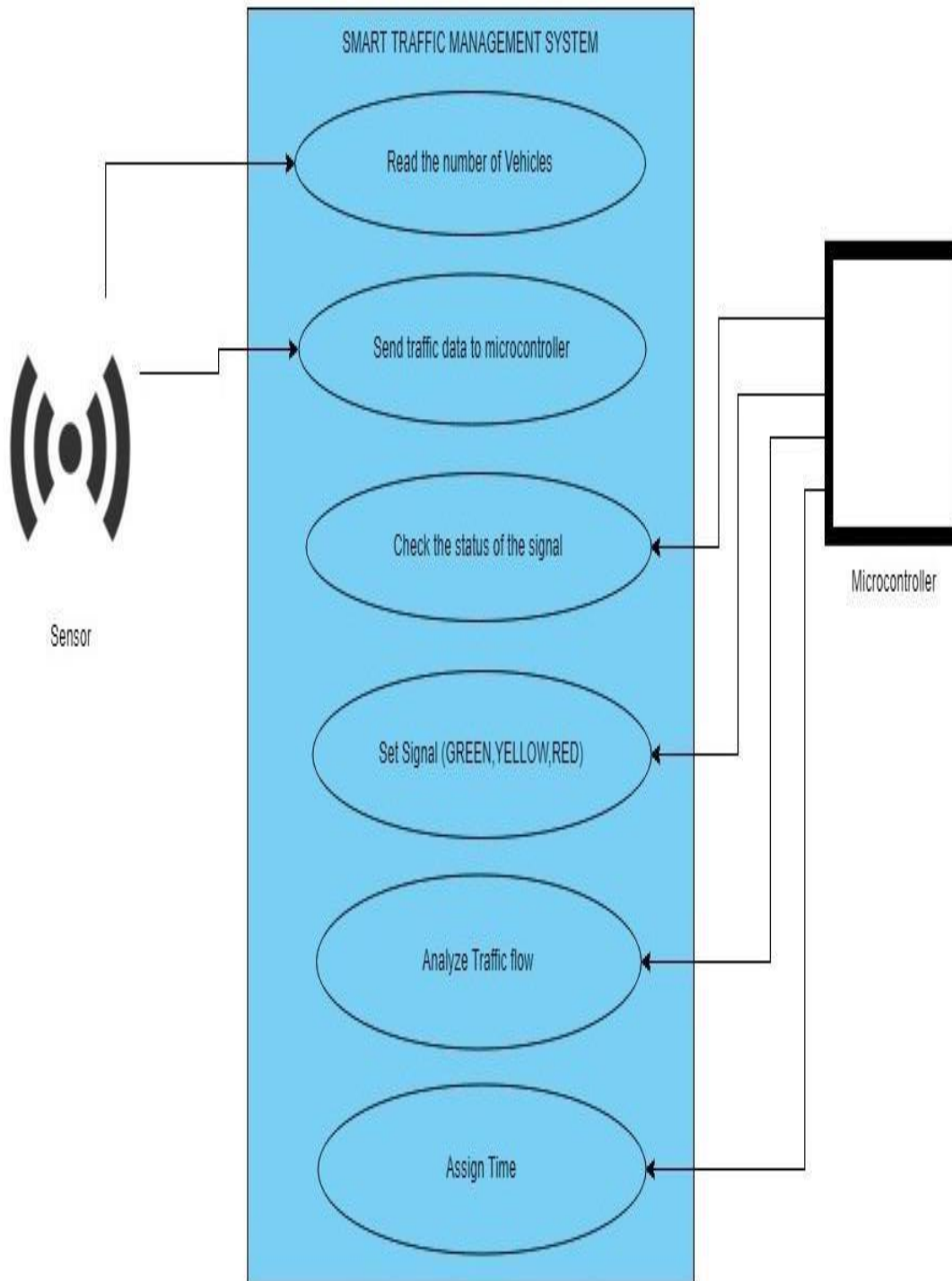

Figure 4.7: Use Case Diagram

4.5 Algorithms

4.5.1 Vehicle Counter Algorithm

Int counter = 0; int hit object = bogus; int val ; int val ; int val ; int val ; int val ; int val ; int val ; int val ; int val ; int val ; int val ; int val ; intval

Stage 1: Take a perusing from the sensor (val). On the off chance that a vehicle is distinguished, the sensor yields 0; else, it yields 1.

In the event that val == 0 and hitObject = bogus,

Stage 2 is to augment the counter and set hitObject = genuine. On the other hand, if val == 1 and hitObject = valid, set hitObject to bogus..

Stage 3: Go to stage 1

4.5.2 Trac Control Algorithm

S1, S2, S3, S4, S5, S6, S7, S8, S9, S10, S11, S12, S13, S14, S15, S16, S17, S18, S19, S20, S21, S22, S23

$N1 = S1 \ S2 = S1 \ S2 = S1 \ S2 = S1 \ S2 = S1 \ S2 = S1$

$N2 = S3 \ S4 = \text{Number of vehicles in Lane 2 (N2)}$

$N3 (\text{Number of vehicles in Lane 3}) = S5 \ S6$

$N4 = S7 + S8 = S7 + S8 = S7 + S8 = S7 + S8 = S7 + S8 = S7 + S8 = S7$

S1, S2, S3, S4, S5, S6, S7, S8, S9, S10, S11, S12, S13, S14, S15, S16, S17, S18, S19, S20, S21, S22, S23

$Ni = (N1, N2, N3, N4), Li = (L1, L2, L3, L4), Ti = (N1, N2, N3, N4) (T1, T2, T3, T4)$

Stage 1: Begin

Stage 2: Sensors can count the number of vehicles travelling in each direction (for instance L1, L2, L3, L4)

Stage 3: if (Vehicle Count Threshold) is true, then

S1, S2, S3, S4, S5, S6, S7, S8, S9, S10, S11, S12, S13, S14, S15, S16, S17, S18, S19, S20, S21, S22, S23

$N_i = (N1, N2, N3, N4)$, $L_i = (L1, L2, L3, L4)$, $T_i = (N1, N2, N3, N4) (T1, T2, T3, T4)$

By that time, the status had changed to Normal trac. Switch on the green light for all of the ways to drive in a clear and continuous manner (L1-L2-L3-L4). When one lane's sign turns green, the others will remain red.

Stage 4: if not, the status is blocked.

S1, S2, S3, S4, S5, S6, S7, S8, S9, S10, S11, S12, S13, S14, S15, S16, S17, S18, S19, S20, S21, S22, S23

$N_i = (N1, N2, N3, N4)$, $L_i = (L1, L2, L3, L4)$, $T_i = (N1, N2, N3, N4) (T1, T2, T3, T4)$

COMPARE (Stage 5) (N1, N2, N3, N4), Choose the most important of the four (say N_i), and toggle on the green sign for that route (say L_i) to save time (T_i). Switch on the red sign exactly when time T_i expires.

COMPARE (Stage 6) (N2, N3, N4), Choose the most important of the three (say N_i), and toggle on the green sign for that direction (say L_i) to save time (T_i). Switch on the red sign exactly when time T_i expires.

COMPARE (Stage 7) (N3, N4), Choose the more important of the two (say N_i), and toggle on the green sign for that route (say L_i) to save time (T_i). Switch on the red sign exactly when time T_i expires.

Stage 8: The final option is usually chosen, and it is given the green hint for time T_i .

Stage 9: Go to Step 3 now.

CHAPTER 5

RESULTS AND ANALYSIS

5.1 Results and Analysis

The proposed framework helps in better time sensitive following and subsequently has a few advantages over the current framework, like decreasing the quantity of wounds, bringing down fuel costs, and being distantly controllable, in addition to other things.

This experimental system was designed to monitor gridlock while also maintaining record of the progress of cars circulating. To keep the machine running, the structure chief employs nearby labourers.

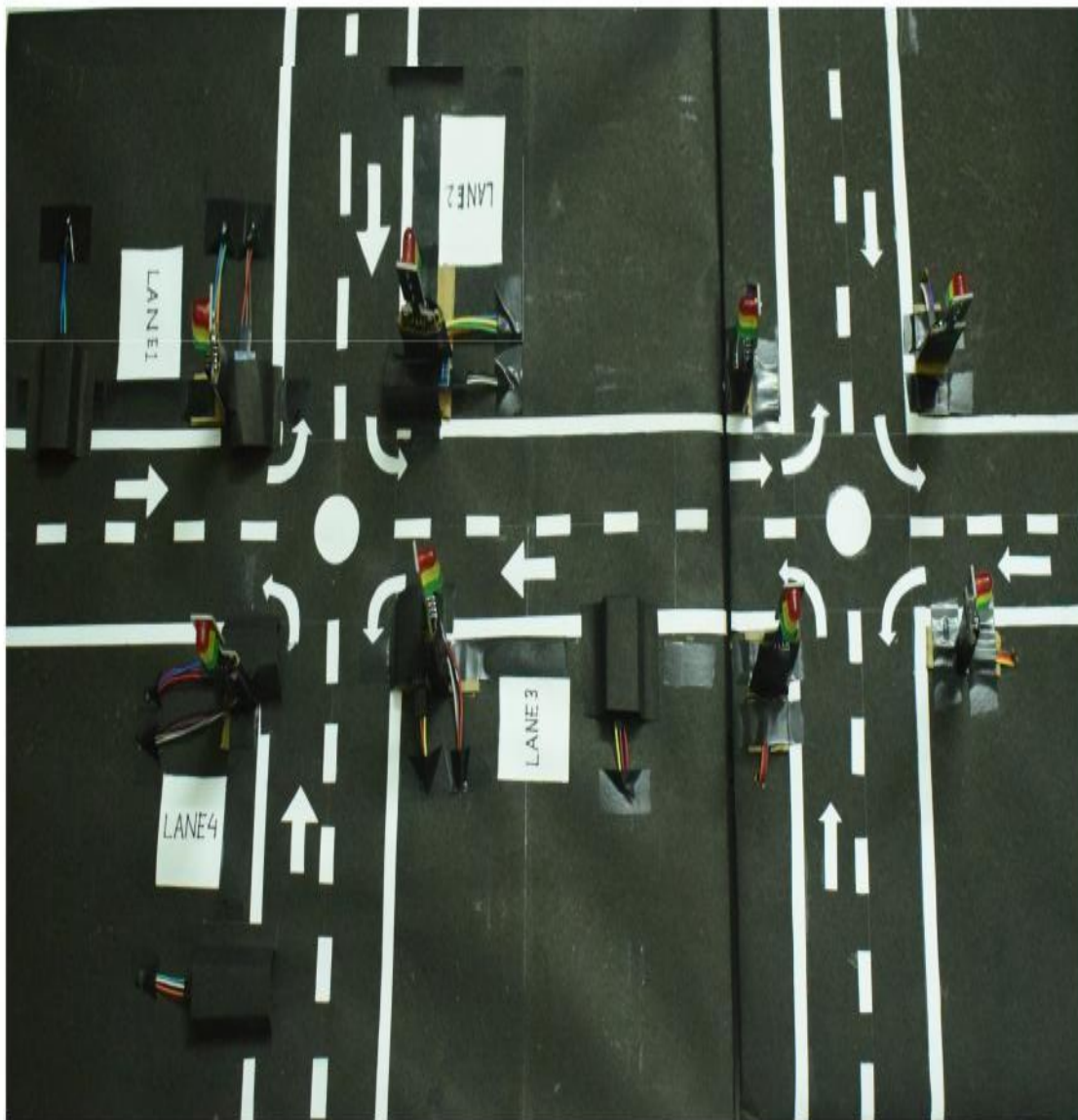

Figure 5.1 Model of the project

5.2Challenges

- 1. Budget constraints:** As graduate students, our ability to test various technology for accuracy is severely restricted.
- 2. Passage for emergency vehicles:** No system for providing passage to emergency vehicles such as ambulances has been enforced.
- 3.Time constraints:** Due to a lack of time, only one sensor-based approach has been introduced.

CHAPTER 6

CONCLUSION AND FUTURESCOPE

6.1 Conclusion

The Smart Trac Management System was made by consolidating various highlights of IoT equipment segments. Trac enhancement is refined with the assistance of an IoT network by dispensing shifting opportunity to all trac signals dependent on the quantity of vehicles out and about course. The executives System for Smart Tracs is carried out to deal with a clog and conduct re-steering at street crossing points

Research study proposes a successful solution for the rapid growth of traffic, especially in large urban areas, which is developing each day, and traditional frameworks have a few restrictions as far as viably overseeing current trac. Considering the most state-of-the-art way to deal with trac the board frameworks, To control street trac circumstances all the more proficiently and adequately, a shrewd trac the executives framework is proposed. It keenly changes signal planning dependent on trac thickness on the particular side of the road and controls trac ow more proficiently than any other time by cooperating with the neighbourhood worker. The decentralised method strengthens and assembles suitability by continuing to operate regardless of whether a region or fused libraries the mark. In addition, the system provides extensive data to higher-level specialists for road masterminding, which aids in resource smoothing out.. (2018, Sabeen Javaid).

6.2 Future Scope

Diverse need levels for various occasions and circumstances might be considered for future headings. A serious issue with IoT is that the whole system is ineffective. assurance shouldis based on rather than a specific IoT layer, device, or programme As a result, integrating the entire trac the executives system with different layer insurance for data generated from various sources is critical. Sources is another subject that could be discussed later. An warning signal for an emergency vehicle (such as a salvage vehicle) can also be used to better support them.

REFERENCES

[1.] P. R. K. S. M. R. Babu, P. R. K. S. M. R. Babu, P. R. K. S. M. R. Bab (2016). Using the snare of things and gigantic data, a steady splendid trac the chiefs system for sharp metropolitan networks is being made. The 2016 International Conference on Emerging Technological Trends will be held in New York City (ICETT).

[2.] Dr. S. Meenakshi Sundaram, Chandana K, C. D. M. N. S. N. K. Dr. S. Meenakshi Sundaram, Chandana K, C. D. M. N. S. N. K. (2013). Using the snare of things, collect a canny trac the board structure for blockage control and alerts (iot). Saudi Journal of Engineering and Technology, Volume 2, Number 2.

[three.]

[3] P. N. D. M. Dave, P. S. P. Dave, P. N. D. M. Dave, P. N. D. M. Dave, P. N. D (2018). IoT-based splendid trac the chiefs system. The twelfth issue of the International Journal of Computer Engineering and Applications is right now open.

[4.] Sabeen Javaid, Ali Suan, S. P. M. T., S. P. M. T., S. P. M. T., S. P. M. T., S. (2018). The snare of things is used to manufacture a splendid trac the leaders system. The 20th International Conference on Advanced Communication Technology is a social affair of experts in the field of bleeding edge correspondence development (ICACT).

[5.] Viswanathan, V. also, Santhanam, V. (2013). Far off sensor networks are used to screen trac signals. ICAEE'2013 is the second Advances in Electrical and Electronics Engineering is an international conference that takes place every two years.

[6.] Y. H. W. Z. Y. Z. Y. Z. Y. Z. Y. Z. Y. Z. Y. Z. Y. Z. Y. Z. Y. Z. Linbing Wang, Yucheng Huang, Y. H. W. Z. Y. Z. Yucheng Huang, Linbing Wang, Y (2018). Volume 11 is a model IoT-based distant sensor network for trac data checking.

S. Zantout [7.] (2017). Keep going report on the Trac light controller project.