

# IMPLEMENTATION OF MODULATION TECHNIQUES

Submitted in partial fulfillment of the Degree of  
Bachelor of Technology



May – 2015

Enrollment No. - 101124  
Name of Student - Dhruv Kamal Sharma  
Name of supervisor(s) - **Prof. Dr. Sunil Bhooshan**

DEPARTMENT OF ELECTRONICS AND COMMUNICATION ENGINEERING  
JAYPEE UNIVERSITY OF INFORMATION TECHNOLOGY,  
WAKNAGHAT, HIMACHAL PRADESH.

*Dedicated to my parents.*

# TABLE OF CONTENTS

<b>Chapter No.</b>	<b>Topics</b>	<b>Page No.</b>
	List of Figures	
	Certificate	
	Abstract	
Chapter 1:	Digital Modulation Techniques	8
	1.1 Digital-to-Analog Conversion	8
	1.2 Modulation	8
	1.3 Demodulation	9
	1.4 Carrier wave	9
	1.5 Advantages of Digital Modulation over Analog Modulation	10
Chapter 2:	Amplitude Shift Keying	11
	2.1 ASK Modulation	12
	2.2 Circuit Diagram of ASK Modulation and Demodulation	13
	2.3 Simulation in pspice software	14
	2.4 Advantages, Disadvantages and uses of ASK	15
	2.5 Probability of error	15
Chapter 3:	Frequency Shift Keying	18
	3.1 FSK	18
	3.2 Circuit Diagram of FSK Modulation and Demodulation	19
	3.3 Simulation in pspice software	19
	3.4 Other forms of FSK	21
	(i) Minimum Shift Keying	21
	(ii) Audio FSK	21
	3.5 Applications	22
Chapter 4:	Phase Shift Keying	23
	4.1 PSK	23
	4.2 Binary Phase Shift Keying	25
	4.3 Circuit Diagram of PSK	25
	4.4 Simulation in pspice software	26
	4.5 Implementation	27
	4.6 Probability of error (BPSK)	28
	4.7 Quadrature Phase Shift Keying (QPSK)	28
	4.8 Implementation	29

4.9 Probability of error (QPSK)	30
4.10 Offset QPSK (OQPSK)	32
4.11 $\pi/4$ – QPSK	33
4.12 High order PSK	35
4.13 Differential Phase Shift Keying	35
4.14 Demodulation	36
4.15 Demodulation of PSK	37
4.16 Applications	38
5. Hardware Implementation	39
6. Conclusion	42
7. References	43
8 Appendix: Software used.	44

## List of figures

S. no.	Title	Page no.
	Fig 1.1: Classification of Modulation	9
	Fig 1.2: Carrier wave	10
	Fig 2.1: Block diagram of ASK	11
	Fig 2.2: BASK modulated signal (lower), together with its input bit stream.	13
	Fig 2.3: Circuit diagram of ASK modulation demodulation.	14
	Fig 2.4: Carrier wave form	14
	Fig 2.5: Input waveform.	14
	Fig 2.6: Output wave form of ASK	15
	Fig 2.7: Output waveform of ASK demodulation	15
	Fig 2.8: Wave form of PHi when L=4	16
	Fig 2.9: Waveform for probability of error	16
	Fig 3.1: FSK with waveform	19
	Fig 3.2: Circuit diagram of FSK modulation and demodulation.	19
	Fig 3.3: Carrier waveform of FSK	19
	Fig 3.4: Input wave form of FSK	20
	Fig 3.5: Output waveform of FSK modulation	20
	Fig 3.6: Output waveform of FSK demodulation.	20
	Fig 4.1: Input, carrier and modulated wave and demodulated wave.	24
	Fig 4.2: Constellation diagram of BPSK	25
	Fig 4.3: Circuit diagram of BPSK	25
	Fig 4.4: Waveforms of carrier	26
	Fig 4.5: Waveforms of input message	26
	Fig 4.6: Waveforms of input message and carrier	27
	Fig 4.7: Waveforms of output	27
	Fig 4.8: Constellation diagram for QPSK with gray coding.	28
	Fig 4.9: Conceptual transmitter structure for QPSK.	30
	Fig 4.10: Block diagram of QPSK	30
	Fig 4.11: Timing diagram for QPSK	31
	Fig 4.12: Constellation diagram of Offset QPSK.	32
	Fig 4.13: Difference of the phase between QPSK and OQPSK	32
	Fig 4.14: Timing diagram for offset-QPSK.	33
	Fig 4.15: Dual constellation diagram for $\pi/4$ -QPSK	33
	Fig 4.16: Timing diagram for $\pi/4$ -QPSK.	34
	Fig 4.17: Constellation diagram for 8-PSK with Gray coding.	35
	Fig 4.18: Timing diagram for DBPSK and DQPSK.	36
	Fig 4.19: Circuit diagram modulation and demodulation.	37
	Fig 4.20: Resultant waveform after demodulation.	37



## Certificate

This is to certify that project report entitled “**IMPLEMENTATION OF MODULATION TECHNIQUES**”, submitted by *Dhruv Kamal Sharma (101124)* in partial fulfillment for the award of degree of Bachelor of Technology in Electronics and Communication Engineering to Jaypee University of Information Technology, Wanknaghat, Solan, has been carried out under my supervision.

This work has not been submitted partially or fully to any other University or Institute for the award of this or any other degree or diploma.

**Date:**

**Prof. Dr. Sunil V. Bhooshan**

**Head of Department (E.C.E)**

**JUIT, Wanknaghat, H.P.**

## **Abstract**

The world is at the apex of a communications revolution. Computers are having an extraordinary impact on the world today. A technological transformation during the last two decades has provided a potential growth in the area of digital communication and lot of newer applications and technologies are coming up everyday due to these reasons. Any information in the form of electrical signal is termed as data and there is a huge requirement of efficient data transfer techniques between two or more places through any means available. The available communication systems have been efficient so far, now, the need to develop better and more secure communication system which can handle the problems of spectral congestion and co-channel interference is necessary.

Digital communication techniques have given better results over its analog counterpart as it provides larger immunity to noise, at the price of large bandwidth requirements. The requirement of video, audio and data over the computer network or the mobile telephony network termed as the third generation (3G) mobile communication poses a serious problem for the bandwidth. So the existing modulation techniques need to be modified for the purpose where it can handle both the situations of noise and bandwidth efficiency. The major advantage of using digital modulation technique is that the use of digital signals reduces hardware noise and interference problems as compared to the analogue signal where large number of waveforms will be required resulting in a larger bandwidth for the symbol to be transmitted.

# **Chapter 1: Digital Modulation Techniques**

In the modern world, most of communication today is in analog form, however, it is now being replaced by digital communication. In the next few years most of the communication will become digital and analog communication will be playing a minor role. Digital communication employs the binary case, where the data consists of only two symbols: 1 and 0. We represent each of these two signals with a distinct waveform (pulse). The resulting sequence of these distinct pulses is transmitted over a channel using a transmitter. At the receiver's end, these pulses are detected and are converted back to binary data (1s and 0s).

The aim of digital modulation is to transfer a digital bit stream modulated over a carrier signal suited for transmission over a channel. A bit stream refers to binary bits of information (1's and 0's) transferred from one device to another. Digital modulation methods can be considered as digital to analog conversion, and the corresponding demodulation or detection as analog to digital conversion. The changes in the carrier signal are chosen from a finite number of  $M$  alternative symbols. The maximum rate of information transfer through a baseband channel is given by:

Capacity fb =  $2 W \log_2 M$  bits per second

Where  $W$  = bandwidth of modulating baseband signal

A modulator is a device that performs modulation, often referred to as a transmitter. A demodulator is a device that performs demodulation (the inverse of modulation), commonly known as receiver. A modem (from **modulator–demodulator**) can perform both operations.

## **1.1 Digital-to-Analog Conversion**

A signal is composed of 1 or more bits. Bit rate is defined as the number of bits per second. Baud rate is the number of signal units per second. Baud rate refers to the number of signal or symbol changes that occur per second. A symbol is subject to one of several voltage, frequency, or phase changes. Bit rate equals the baud rate times the number of bits represented by each signal unit and Baud rate equals the bit rate divided by the number of bits represented by each signal unit. Baud rate is less than or equal to the bit rate and determines the bandwidth required to send the signal in a channel.

## **1.2 Modulation**

Modulation is the process of varying one or more properties of a high-frequency periodic waveform, called the carrier signal, with a modulating signal, which contains data to be transmitted. Modulation of a sine waveform is used to transform a baseband message signal into a passband signal. Modulation is the transmission of a signal by using it to vary different properties of a carrier wave i.e. amplitude, frequency or phase. The transmitter is an electronic device that generates and amplifies a carrier wave used for digital modulation.



### 1.3 Demodulation

Demodulation is extraction of the original information-bearing signal from a modulated carrier wave. These terms are traditionally used in connection with radio receivers, but many other systems use many kinds of demodulators. There are several ways of demodulation depending on how parameters of the base-band signal are transmitted in the carrier signal, such as amplitude, frequency or phase. The receiver is an electronic device which extracts the original data from the carrier wave.

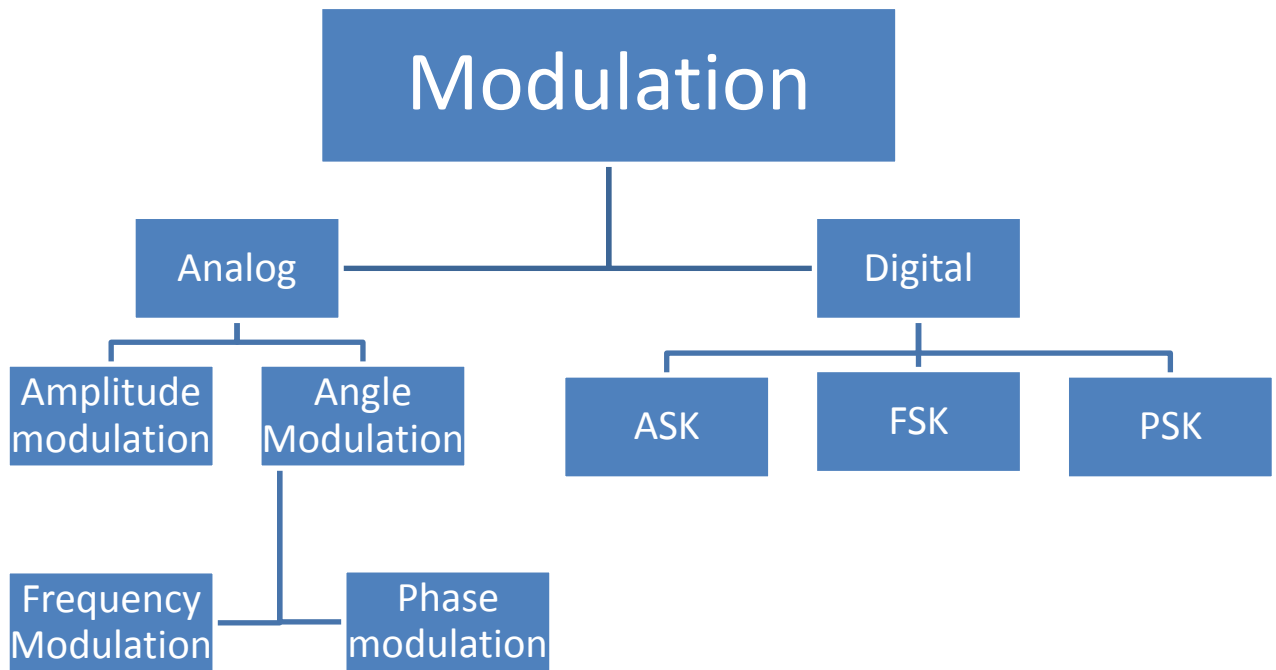

Fig 1.1: Classification of Modulation

### 1.4 Carrier Wave

Carrier wave is an electromagnetic wave that can be modulated, as in frequency, phase or amplitude to transmit information bearing data signal over a channel. In analog signal, the transmitter produces a high-frequency signal that acts as a basis for the information signal. This base signal is called the carrier wave or carrier frequency. The receiver is tuned to the frequency of the carrier wave that it expects from the Transmitter. Data in digital form is then modulated over the carrier signal by modifying one or more of its characteristics (amplitude, frequency, or phase). This kind of modification of the carrier wave is called modulation (or shift keying, and the information signal is called the modulating signal.

In telecommunications, a carrier signal, carrier wave, or just carrier, is a waveform (usually sinusoidal) that is modulated (modified) with an input signal for the purpose of conveying information. This carrier wave is usually a much higher frequency than the input signal. The purpose of the carrier is usually either to transmit the information through space as an

electromagnetic wave (as in radio communication), or to allow several carriers at different frequencies to share a common physical transmission medium by frequency division multiplexing (as, for example, a cable television system). The term is also used for an unmodulated emission in the absence of any modulating signal.

Frequency modulation (FM) and amplitude modulation (AM) are common modes of modulating the carrier. In the case of single-sideband modulation (SSB), the carrier is suppressed (and in some forms of SSB, eliminated). The carrier must be reintroduced at the receiver by a beat frequency oscillator (BFO). The frequency of a radio or television station is actually the carrier wave's centre frequency.

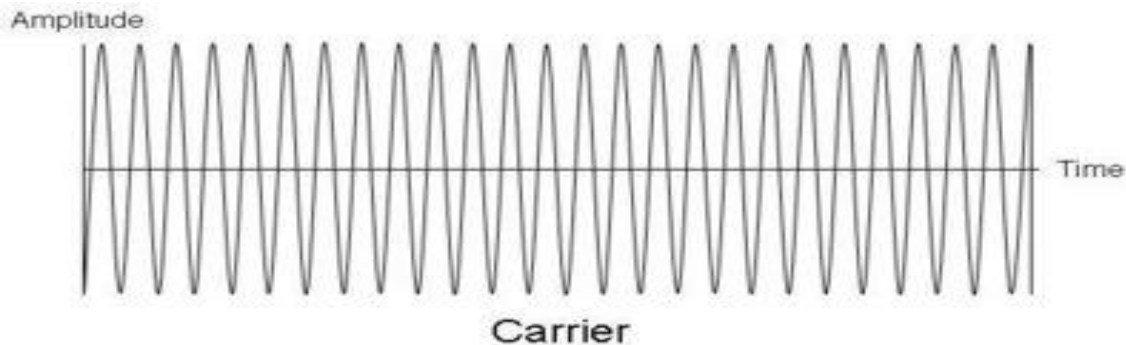

Fig 1.2: carrier wave

Source: [http://www.hill2dot0.com/wiki/index.php?title=Frequency\\_modulation](http://www.hill2dot0.com/wiki/index.php?title=Frequency_modulation)

## 1.5 Advantages of Digital Modulation over Analog Modulation

Digital modulation is more flexible than analog modulation as it gives complete freedom to multiplex digital data, voice and video information. Digital systems tend to be less susceptible to waveform distortion, such as crosstalk and noise as compared to their analog counterparts.

The main advantage of digital modulation over analog modulation is that it is less prone to noise error as all input and output is in binary form. The modulator in the transmission system, rejects anything that isn't a 1 or a 0. This filters out a lot of channel noise that analog modulation allows, which may not be related to the intended message. Digital modulation can easily detect and correct the noise. Although, analog modulation has better security as compared to digital modulation, it is a more complex by design

## Chapter 2 : Amplitude shift keying

Amplitude-shift keying (ASK) is the simplest digital modulation technique. In this, the binary information signal directly modulates the amplitude of the analog carrier wave. ASK is similar to the standard amplitude modulation except there are only two output amplitudes possible. ASK is sometimes called digital amplitude modulation (DAM).

Mathematically, amplitude shift keying is

$$V_{(ask)}(t) = [1 + v_m(t)] \left[ \frac{A}{2} \right] \cos(\omega_c t)$$

Where,  $V_{(ask)}(t)$  = Amplitude shift keying wave.

$v_m(t)$  = digital information (modulating signal in volts)

$A/2$  = carrier amplitude in volts.

$\omega_c$  = analog carrier radian frequency (radians per second,  $2\pi f_c t$ )

In above equation, the modulating signal  $[v_m(t)]$  is normalized binary waveform, where  $+1V$  = logic 1 and  $-1V$  = logic 0. Therefore, for a logic 1 input,  $[v_m(t)] = +1V$ , above equation is reduced to

$$V_{(ask)}(t) = [1 + 1] \left[ \frac{A}{2} \right] \cos(\omega_c t) = A \cos(\omega_c t)$$

And for logic 0 input,  $[v_m(t)] = -1V$ , above equation reduces to

$$V_{(ask)}(t) = [1 - 1] \left[ \frac{A}{2} \right] \cos(\omega_c t) = 0$$

Thus, the modulated wave,  $V_{(ask)}(t)$  is either  $A \cos(\omega_c t)$  or 0. Hence, the carrier wave is either “on” or “off”, which is why amplitude shift keying is sometimes referred to as on-off keying (OOK).

Amplitude shift keying is a modulation technique which uses a number of distinct signals to represent digital data. ASK uses a finite number of amplitudes, each assigned a unique pattern of binary digits. Usually, every amplitude rise or fall encodes an equal number of bits. Each pattern of bits forms the symbol that is represented by the particular amplitude. The simplest and most common form of ASK operates as a switch, using the presence of a carrier wave to indicate a binary one and its absence to indicate a binary zero. This type of modulation is called on-off keying, and is used at radio frequencies to transmit Morse code (referred to as continuous wave operation).

ASK system can be divided into three blocks as shown in fig:

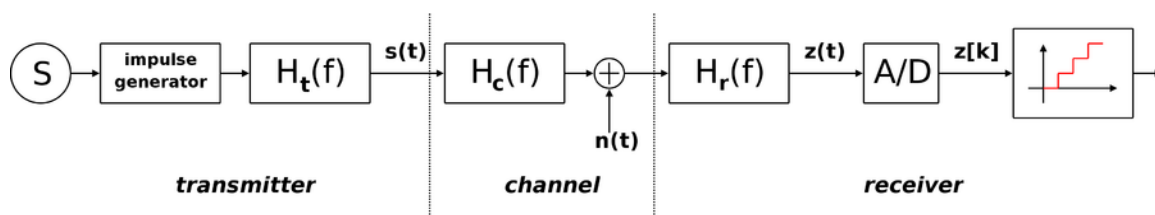

Fig 2.1: Block diagram of ASK  
Source : [en.wikipedia.org/wiki/Amplitude-shift\\_keying](http://en.wikipedia.org/wiki/Amplitude-shift_keying)

The first one represents the transmitter, the second one is a linear model of the effects of the channel, and the third one shows the structure of the receiver. The following notation is used:

$H_t(f)$  is the carrier signal for the transmission

$H_c(f)$  is the impulse response of the channel

$n(t)$  is the noise introduced by the channel

$H_r(f)$  is the filter at the receiver

$L$  is the number of levels that are used for transmission

$T_s$  is the time between the generation of two symbols

## 2.1 ASK modulation:

ASK in the context of digital communications is a modulation process, which imparts to a sinusoid two or more discrete amplitude levels. These are related to the number of levels adopted by the digital message. For a binary message sequence there are two levels, one of which is typically zero. Thus the modulated waveform consists of bursts of a sinusoid. A binary ASK (BASK) wave is obtained by multiplying the message signal with the carrier. The B-ASK signal has two levels '1' and '0' representing the presence and absence of the sinusoid respectively. This is shown in the waveform below. The message signal must be represented in NZR uni-polar format. Binary ASK system has the largest probability of bit error when compared to FSK and PSK systems. There are sharp discontinuities shown at the transition points. These result in the signal having an unnecessarily wide bandwidth. Band limiting is generally introduced before transmission, in which case these discontinuities would be 'rounded off'. The band limiting may be applied to the digital message, or the modulated signal itself.

In the modulation process, the baseband signals constitute the modulating signal and the high-frequency carrier signal is a sinusoidal waveform. Modulation also leads to the possibility of frequency multiplexing. In a frequency-multiplexed system, individual signals are transmitted over adjacent, non-overlapping frequency bands. They are therefore transmitted in parallel and simultaneously in time. If we operate at higher carrier frequencies, more bandwidth is available for frequency-multiplexing more signals.

ASK modulation signal can be expressed as

$$X_{\text{ask}}(t) = A_i \cos(\omega_c t + \phi_0); \quad 0 \leq t \leq T, i=1,2,\dots,M$$

$\omega_c$  : Cutoff frequency.

$\phi_0$  : Phase

In above equation, the values of amplitude  $A_i$  have  $M$  types of possible change, the  $\omega_c$  and  $\phi_0$  denote the cutoff frequency and phase, respectively. If we choose  $M=2$ , the  $X_{\text{ask}}(t)$  signal will transmit the binary signal, therefore, the values of  $A$  are  $A_1=0$  and  $A_2=A$ , where  $A$  is the arbitrary constant so we can obtain the binary ASK modulated signal waveform as shown in figure below, when input logic is 1, and then the signal is transmitted out. When the input logic is 0, then no signal is transmitted, so this also called on-off keying (OOK), this type of method is used in the past time.

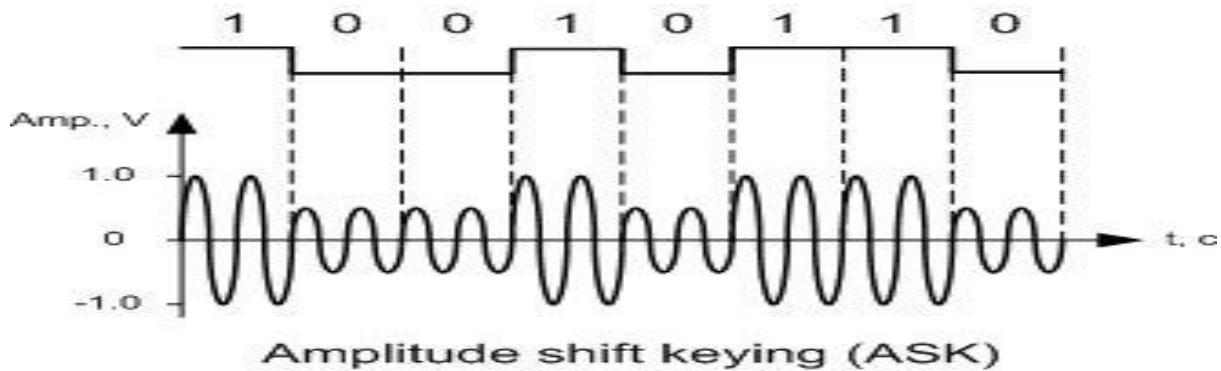

Fig 2.2: A BASK modulated signal (lower), together with its input bit stream.

Source: [www.swharden.com/blog/2013-05-19-wireless-microcontroller-pc-interface-for-3-21/](http://www.swharden.com/blog/2013-05-19-wireless-microcontroller-pc-interface-for-3-21/)

We can also express the transmitted waveforms of ASK as

$$s_1(t) = 4E_b \cos(2\pi f_c t) \quad T_b$$

$$s_2(t) = 0$$

for  $0 \leq t \leq T_b$ , where  $E_b$  is the averaged transmitted signal energy per bit and the carrier frequency which is equal to  $n_c/T$  for some fixed integer  $n_c$ . And the averaged transmitted energy is expressed as follows:

$$0.5 \int_0^{T_b} s_1(t) dt + 0.5 \int_0^{T_b} s_2(t) dt = E_b$$

The transmitted signal  $s(t)$  can be expressed as

$$s(t) = \begin{cases} s_1(t) & \text{for symbol "1"} \\ s_2(t) & \text{for symbol "0"} \end{cases} \quad \text{for } 0 \leq t \leq T_b$$

## 2.2 Circuit diagram of ASK Modulation and Demodulation

Parameters for simulation.

Input frequency =  $1/t$

$$\text{Where } t = 1\text{ms} + 1\text{ms} = 2\text{ms}$$

$$\text{Therefore } f = 1/2\text{ms} = 0.5\text{kHz}$$

Usually for carrier frequency we take 10 times the input frequency.

$$\text{Therefore } f = 7\text{KHz}$$

$$R_1 = (V_{cc} - V_{be}) / I_b$$

$$R_3 = V_{cc} / R_c$$

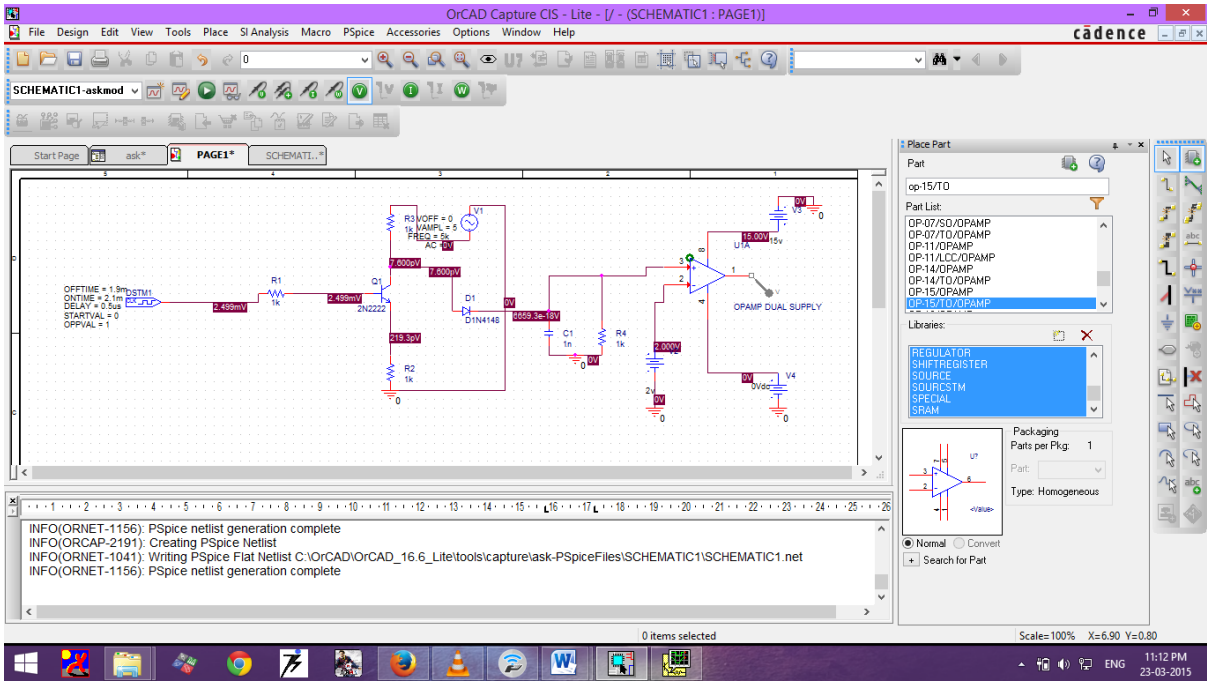

Fig 2.3: circuit diagram of ASK modulation demodulation.

## 2.3 Simulation in pspice software

Wave form of ASK in pspice.

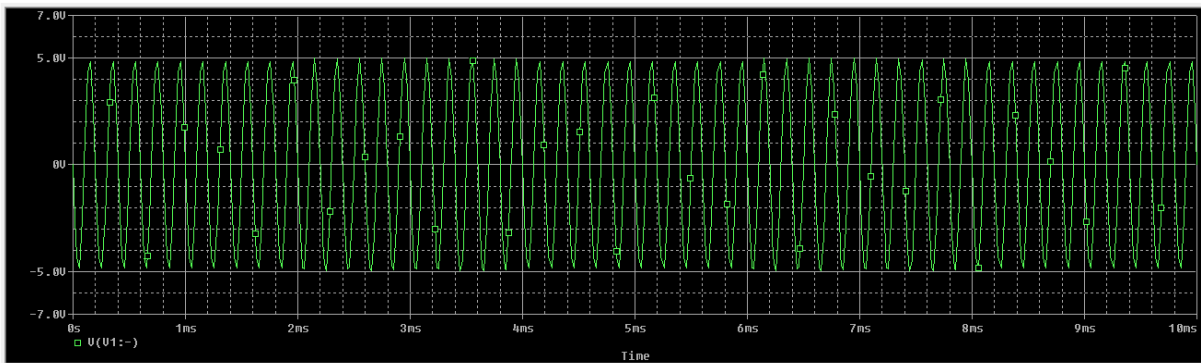

Fig 2.4: carrier wave form

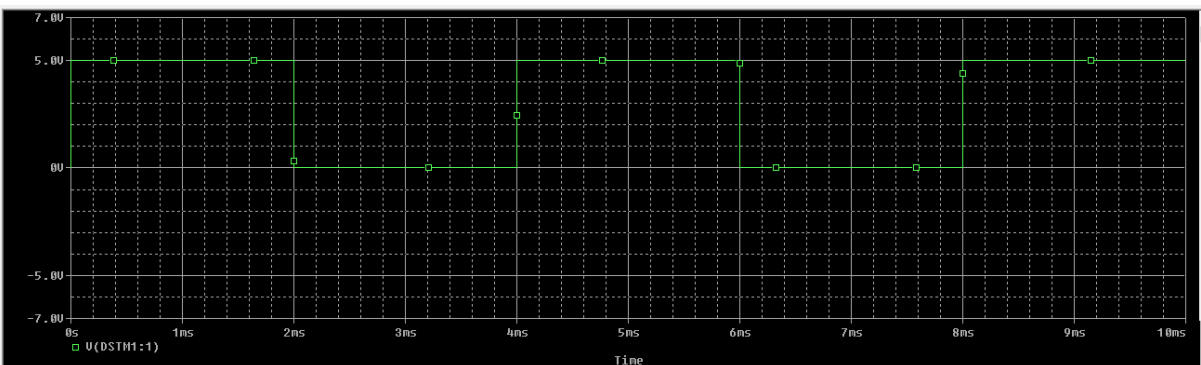

Fig 2.5: input waveform.

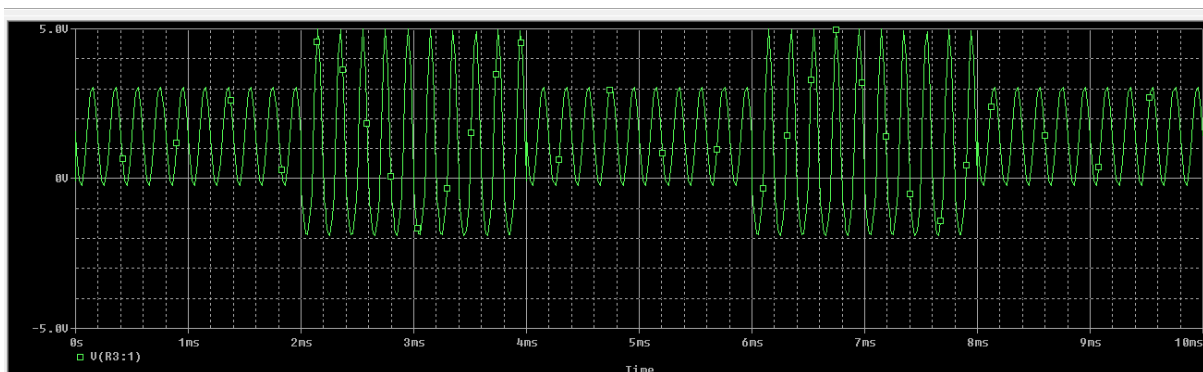

Fig 2.6: output wave form of ASK

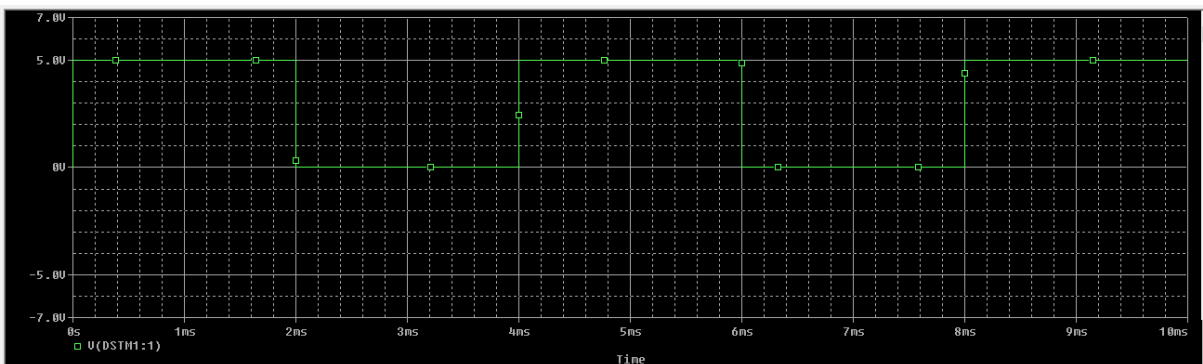

Fig 2.7: Output waveform of ASK demodulation.

## 2.4 Advantage, disadvantage and uses of ASK:

ASK is also linear and is susceptible to noise interference. Noise refers to unintentional voltages introduced onto a line by various phenomena such as heat or electromagnetic induction created by other sources. Both ASK modulation and demodulation processes are relatively inexpensive. One of the disadvantages of ASK, compared with FSK and PSK, for example, is that it does not have a constant envelope. This makes its processing (eg, power amplification) more difficult, since linearity becomes an important factor. However, it does make for ease of demodulation with an envelope detector.

## 2.5 Probability of error:

The probability density function of having an error of a given size can be modeled by a Gaussian function, the mean value will be the relative sent value, and its variance will be given by:

$$\sigma_N^2 = \int_{-\infty}^{+\infty} \Phi_N(f) \cdot |H_r(f)|^2 df$$

[1]

Where  $\Phi_N(f)$  is the spectral density of the noise within the band and  $Hr(f)$  is the continuous Fourier transform of the impulse response of the filter  $hr(f)$ .

The probability of making an error is given by:

$$P_e = P_{e|H_0} \cdot P_{H_0} + P_{e|H_1} \cdot P_{H_1} + \dots + P_{e|H_{L-1}} \cdot P_{H_{L-1}} \quad [1]$$

Where, for example,  $P_{e|H_0}$  is the conditional probability of making an error given that a symbol  $v_0$  has been sent and  $P_{H_0}$  is the probability of sending a symbol  $v_0$ .

If the probability of sending any symbol is the same, then:

$$P_{H_i} = \frac{1}{L} \quad [1]$$

If we represent all the probability density functions on the same plot against the possible value of the voltage to be transmitted, we get a picture like figure below (the particular case of  $L = 4$  is shown):

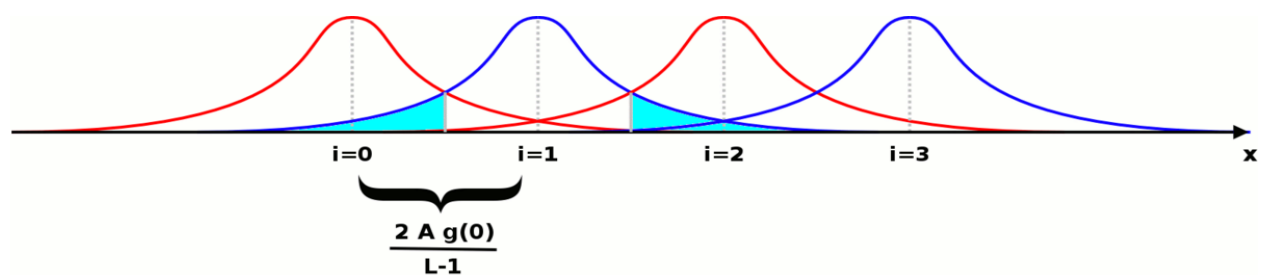

Fig 2.8: wave form of  $P_{H_i}$  when  $L=4$

Source : [en.wikipedia.org/wiki/Amplitude-shift\\_keying](https://en.wikipedia.org/wiki/Amplitude-shift_keying)

The probability of making an error after a single symbol has been sent is the area of the Gaussian function falling under the functions for the other symbols. It is shown in cyan for just one of them. If we call  $P^+$  the area under one side of the Gaussian, the sum of all the areas will be:  $2 L P^+ - 2 P^+$ . The total probability of making an error can be expressed in the form:

$$P_e = 2 \left(1 - \frac{1}{L}\right) P^+$$

We have now to calculate the value of  $P^+$ . In order to do that, we can move the origin of the reference wherever we want and the area below the function will not change. We are in a situation like the one shown in the following figure below,

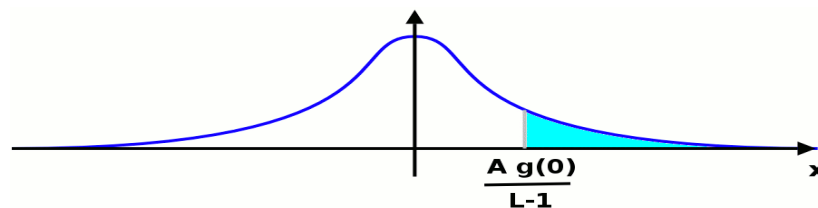

Fig 2.9: waveform for probability of error

Source : [en.wikipedia.org/wiki/Amplitude-shift\\_keying](https://en.wikipedia.org/wiki/Amplitude-shift_keying)



It does not matter which Gaussian function we are considering, the area we want to calculate will be the same. The value we are looking for will be given by the following integral:

$$P^+ = \int_{\frac{Ag(0)}{L-1}}^{\infty} \frac{1}{\sqrt{2\pi}\sigma_N} e^{-\frac{x^2}{2\sigma_N^2}} dx = \frac{1}{2} \operatorname{erfc} \left( \frac{Ag(0)}{\sqrt{2}(L-1)\sigma_N} \right)$$

[1]

Where  $\operatorname{erfc}$  is the complementary error function. Putting all these results together, the probability to make an error is:

$$P_e = \left( 1 - \frac{1}{L} \right) \operatorname{erfc} \left( \frac{Ag(0)}{\sqrt{2}(L-1)\sigma_N} \right)$$

[1]

from this formula we can easily understand that the probability to make an error decreases if the maximum amplitude of the transmitted signal or the amplification of the system becomes greater; on the other hand, it increases if the number of levels or the power of noise becomes greater.

## Chapter 3: Frequency Shift Keying

### 3.1 FSK

Frequency shift keying (FSK) is another relatively simple, low performance type of digital modulation scheme. FSK is a form of constant amplitude angle modulation similar to standard frequency modulation except the modulating signal is a binary signal that varies between two discrete voltage levels rather than a continuously changing analog waveform. FSK is sometimes also called binary FSK (BFSK). The general expression for FSK is

$$V_{(fsk)}(t) = v_c \cos[2\pi[f_c + v_m(t)\Delta f]t]$$

Where,  $V_{(fsk)}(t)$  = frequency shift keying wave

$v_c$  = peak analog carrier amplitude (volts)

$f_c$  = analog carrier center frequency (hertz)

$\Delta f$  = peak change (shift) in analog carrier frequency (hertz)

$v_m(t)$  = binary input (modulating signal) (volts)

The modulating signal is a normalized binary waveform where a logic 1 = +1V and a Logic 0 = -1 V. Thus, for a logic 1 input,  $v_m(t) = +1$ , and the above equation becomes

$$V_{(fsk)}(t) = v_c \cos[2\pi(f_c + \Delta f)t]$$

For logic 0 input,  $v_m(t) = -1$ , and the above equation becomes

$$V_{(fsk)}(t) = v_c \cos[2\pi(f_c - \Delta f)t]$$

With binary FSK, the carrier center frequency ( $f_c$ ) is shifted (deviated) up and down in the frequency domain by the input signal. As the binary input signal changes from logic 0 to logic 1 and vice versa, the output frequency shifts between two frequencies: a mark, or logic 1 frequency ( $f_m$ ) and a space, or logic 0 frequency ( $f_s$ ). The mark and space frequencies are separated from the carrier frequency by the peak deviation ( $\Delta f$ ) and from each other by  $2\Delta f$ .

With FSK, frequency deviation is defined as the difference between either mark or space frequencies and the center frequency, or half the difference between the mark and space frequencies, frequency deviation is expressed as

$$\Delta f = \frac{|f_m - f_s|}{2}$$

Where,  $\Delta f$  = frequency deviation (hertz)

$|f_m - f_s|$  = absolute difference between mark and space frequencies (hertz).

Frequency-shift keying (FSK) is a frequency modulation scheme in which digital data is transmitted through specific frequency modulation of a carrier wave. The simplest form of FSK is binary FSK (BFSK).

BFSK uses a pair of discrete frequencies to transmit binary logic (0s and 1s) information. In this process, the "1" is called the mark frequency and the "0" is called the space frequency. The time domain of an FSK modulated carrier is illustrated in the figures to the right.

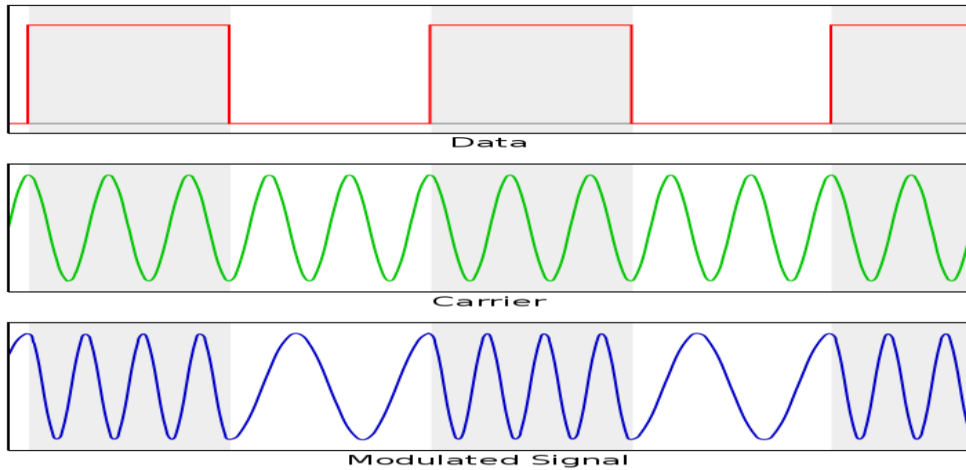

Fig 3.1: FSK waveforms

Source : [en.wikipedia.org/wiki/Frequency-shift\\_keying](https://en.wikipedia.org/wiki/Frequency-shift_keying)

### 3.2 Circuit diagram of FSK modulation and demodulation

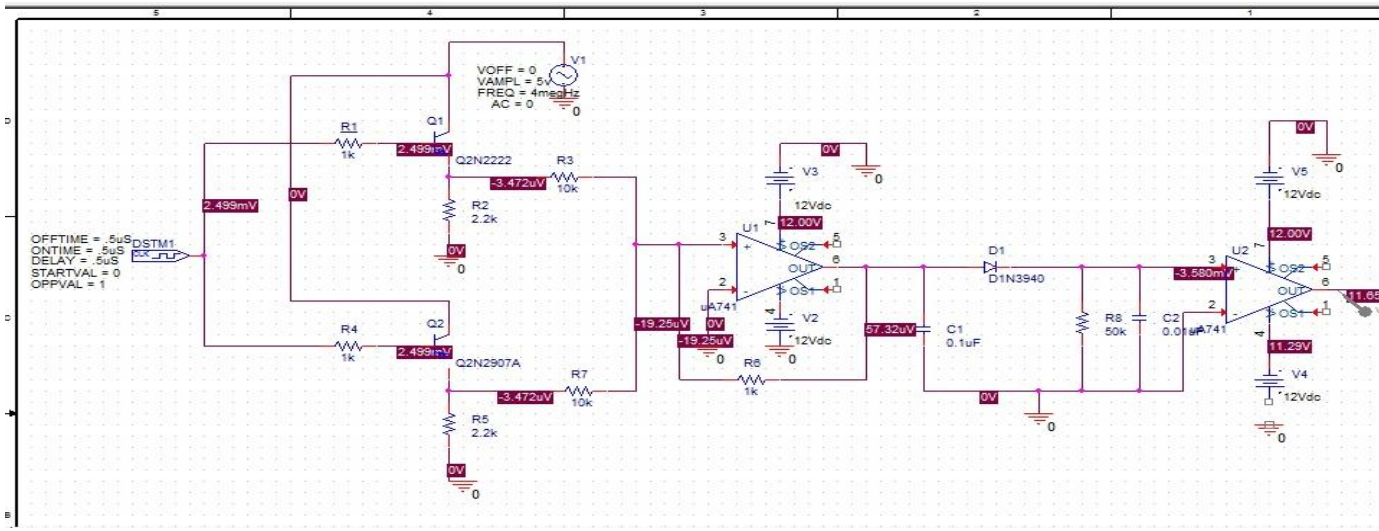

Fig 3.2: circuit diagram of FSK modulation and demodulation.

### 3.3 Simulation in Pspice software

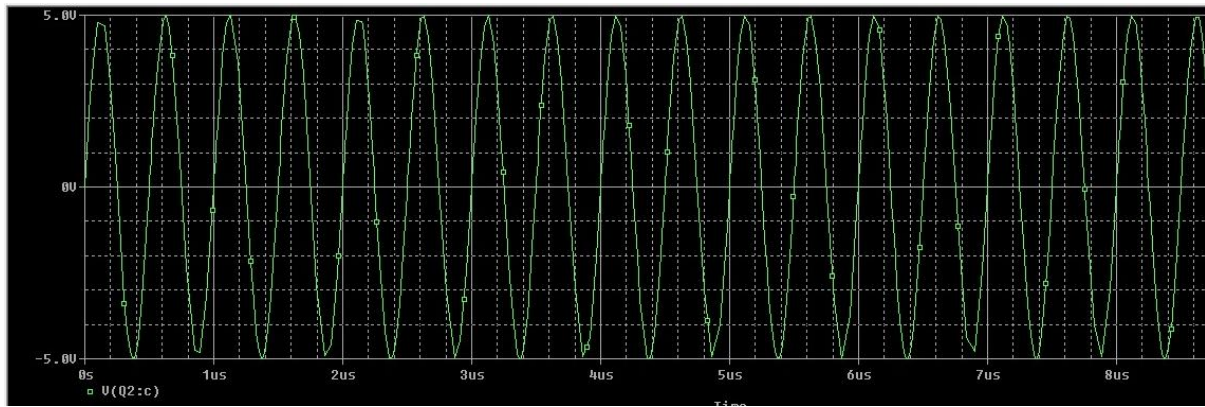

Fig 3.3: carrier wave form of FSK

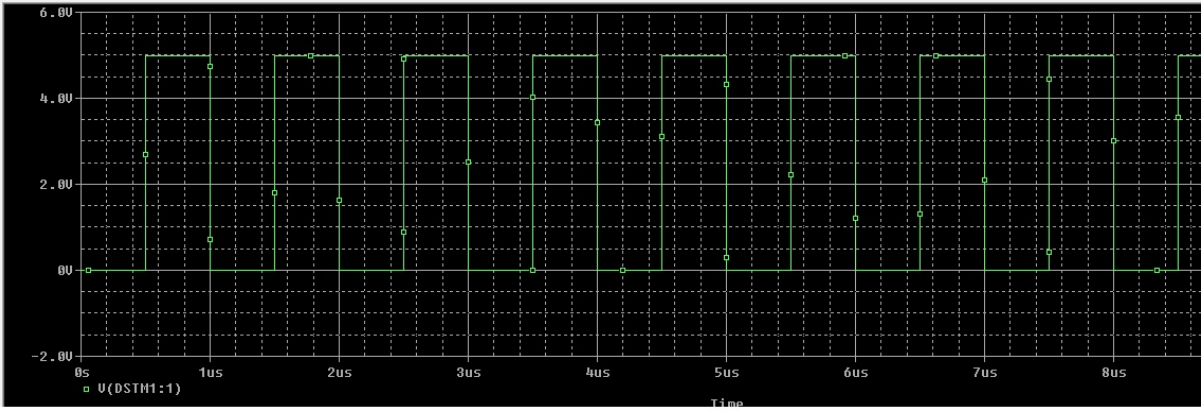

Fig 3.4: input wave form of FSK

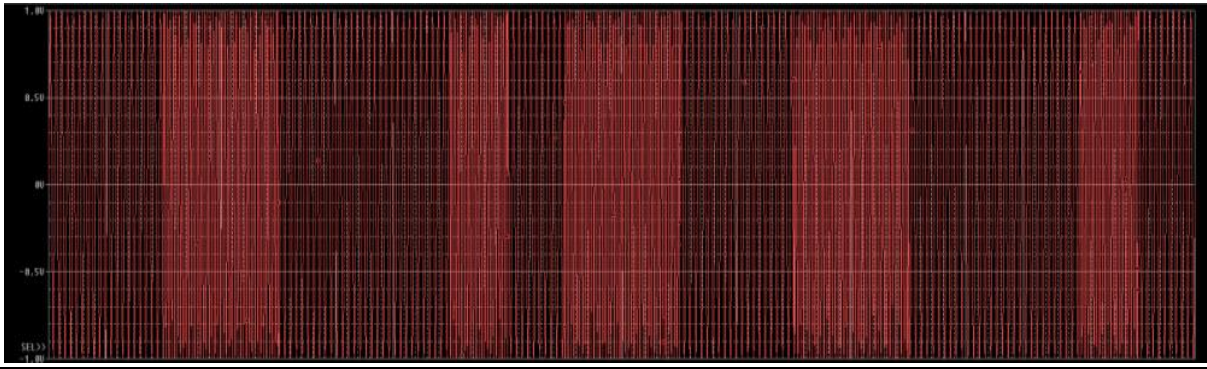

Fig 3.5: output waveform of FSK modulation.

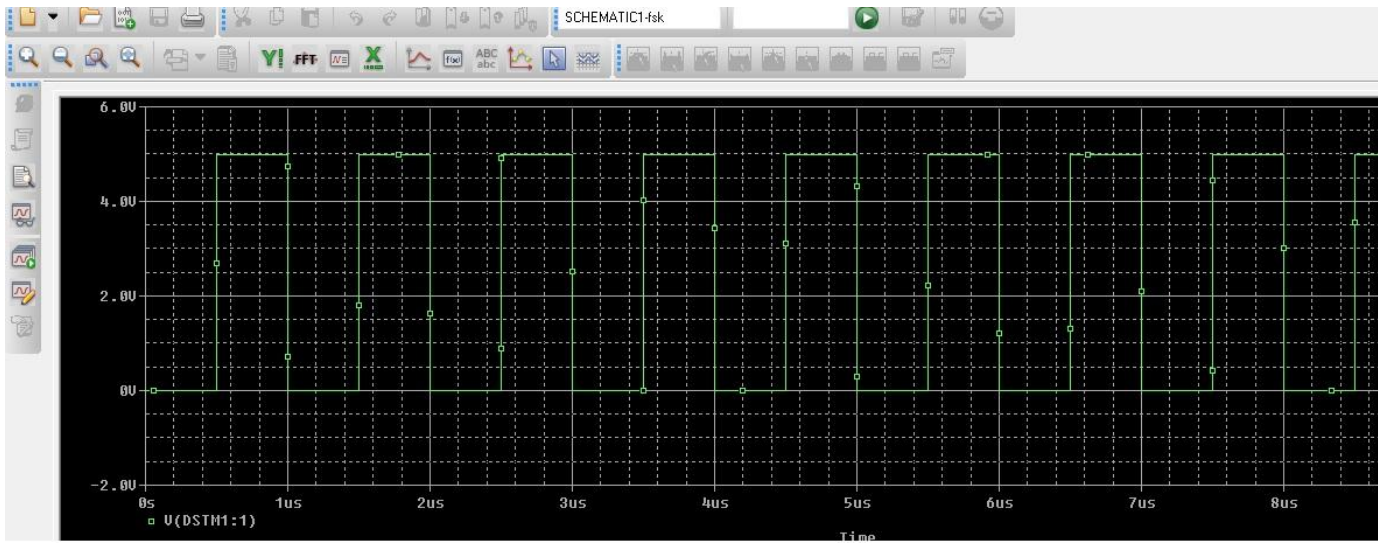

Fig 3.6 output waveform of FSK demodulation.

## 3.4 Other forms of FSK

### i. Minimum-shift keying

Minimum shift keying (MSK) is a spectrally efficient form of coherent FSK. In MSK, the difference between the higher and lower frequency is identical to half the bit rate. Hence, the waveforms that represent logic 0 and logic 1 bit differ by exactly half a carrier period. The maximum frequency deviation is  $\delta = 0.25 f_m$ , where  $f_m$  is the maximum modulating frequency. As a result, the modulation index  $m$  is 0.5. This is the smallest FSK modulation index that can be chosen such that the waveforms for 0 and 1 are orthogonal. A variant of MSK called GMSK is used in the GSM mobile phone standard.

### ii. Audio FSK

Audio frequency-shift keying (AFSK) is a modulation technique by which digital data is represented by changes in the frequency (pitch) of an audio tone, yielding an encoded signal suitable for transmission via radio or telephone. Normally, the transmitted audio alternates between two tones: one, the "mark", represents a binary one; the other, the "space", represents a binary zero.

AFSK differs from regular frequency-shift keying in performing the modulation at baseband frequencies. In radio applications, the AFSK-modulated signal normally is being used to modulate an RF carrier (using a conventional technique, such as AM or FM) for transmission.

AFSK is not always used for high-speed data communications, since it is far less efficient in both power and bandwidth than most other modulation modes. In addition to its simplicity, however, AFSK has the advantage that encoded signals will pass through AC-coupled links, including most equipment originally designed to carry music or speech.

AFSK is used in the U.S. based Emergency Alert System to notify stations of the type of emergency, locations affected, and the time of issue without actually hearing the text of the alert.

## 3.5 Applications

In 1910, a two-tone method of transmitting Morse code was invented by Reginald Fessenden. Dots and dashes were different tones of equal length. The intent was to minimize transmission time and error in transmission.

Early CW transmitters employed an arc converter that could not be conveniently keyed. Instead of turning the arc on and off, the key slightly changed the transmitter frequency in a technique known as the compensation-wave method. The compensation-wave was not used at the receiver. The method consumed a lot of bandwidth and caused interference, so it was discouraged by 1921.

Most early telephone-line modems used audio frequency-shift keying (AFSK) to send and receive data at rates up to about 1200 bits per second. The common Bell 103 and Bell 202 modems used this technique. Even today, North American caller ID uses 1200 baud AFSK in the form of the Bell 202 standard. Some early microcomputers used a specific form of AFSK modulation, the Kansas City standard, to store data on audio cassettes [citation needed]. AFSK is still widely used in amateur radio, as it allows data transmission through unmodified voiceband equipment. Radio control gear uses FSK, but calls it FM and PPM instead.

AFSK is also used in the United States' Emergency Alert System to transmit warning information [citation needed]. It is used at higher bitrates for Weather copy used on Weatheradio by NOAA in the U.S.

## Chapter 4: Phase Shift Keying

### 4.1 PSK

Digital modulation is a process in which one of the characteristics of the carrier signal is varied according to the data to be transmitted so that it is compatible with characteristics of the channel. The BPSK modulation technique is simplest and most robust of all PSK modulation techniques since it takes the highest level of noise or distortion to make the demodulator reach an incorrect decision. It is however, only able to modulate at 1bit/symbol and so, it is unsuitable for high data rate applications. BPSK is a modulation technique in which the phase of the carrier signal is varied according to the modulating input signal. BPSK modulation uses the data stream's logic 1 and logic 0 to switch the carrier between two phases.

Phase shift keying is a digital communication scheme that conveys data by changing, or modulating, the phase of a reference signal (the carrier wave).

Any digital modulation scheme uses a finite number of distinct signals to represent digital data. PSK uses a finite number of phases, each assigned a unique pattern of binary digits. Usually, each phase encodes an equal number of bits. Each pattern of bits is represented by the particular phase. The demodulator, which is designed specifically for the symbol-set used by the modulator, determines the phase of the received signal and maps it back to the symbol it represents, thus recovering the original data. This requires the receiver to be able to compare the phase of the received signal to a reference signal — such a system is termed coherent (and referred to as CPSK). Alternatively, instead of operating with respect to a constant reference wave, the broadcast can operate with respect to itself. Changes in phase of a single broadcast waveform can be considered the significant items.

In this system, the demodulator determines the changes in the phase of the received signal rather than the phase (relative to a reference wave) itself. Since this scheme depends on the difference between successive phases, it is termed **differential phase-shift keying (DPSK)**. DPSK can be significantly simpler to implement than ordinary PSK since there is no need for the demodulator to have a copy of the reference signal to determine the exact phase of the received signal (it is a non-coherent scheme). In exchange, it produces more erroneous demodulation.

Enter The Input data Sequence : [1 0 1 0 1 1 0 0]

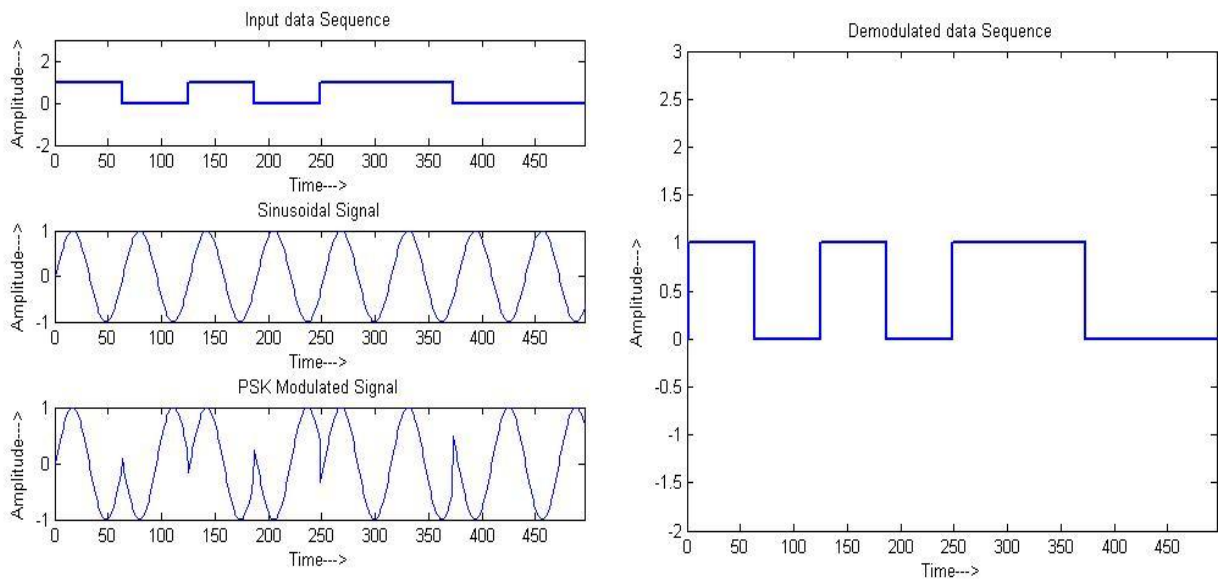

Fig 4.1: Input, carrier and modulated wave and demodulated wave.

Source : [www.technologyuk.net](http://www.technologyuk.net)

All convey data by changing some aspect of a base signal, the carrier wave (usually a sinusoid), in response to a data signal. In the case of PSK, the phase is changed to represent the data signal. There are two fundamental ways of utilizing the phase of a signal in this way:

- By viewing the phase itself as conveying the information, in which case the demodulator must have a reference signal to compare the received signal's phase against; or
- By viewing the *change* in the phase as conveying information — *differential* schemes, some of which do not need a reference carrier (to a certain extent).

A convenient way to represent PSK schemes is on a constellation diagram. This shows the points in the complex plane where, in this context, the real and imaginary axis are termed the in-phase and quadrature axes respectively due to their  $90^\circ$  separation. Such a representation on perpendicular axes lends itself to straightforward implementation. The amplitude of each point along the in-phase axis is used to modulate a cosine (or sine) wave and the amplitude along the quadrature axis to modulate a sine (or cosine) wave.

In PSK, the constellation points chosen are usually positioned with uniform angular spacing around a circle. This gives maximum phase-separation between adjacent points and thus the best immunity to corruption. They are positioned on a circle so that they can all be transmitted with the same energy. In this way, the moduli of the complex numbers they represent will be the same and thus so will the amplitudes needed for the cosine and sine waves. Two common examples are "binary phase-shift keying" (BPSK) which uses two phases, and "quadrature phase-shift keying" (QPSK) which uses four phases, although any number of phases may be used. Since the data to be conveyed are usually binary, the PSK scheme is usually designed with the number of constellation points being a power of 2.



## 4.2 Binary phase –shift keying (BPSK)

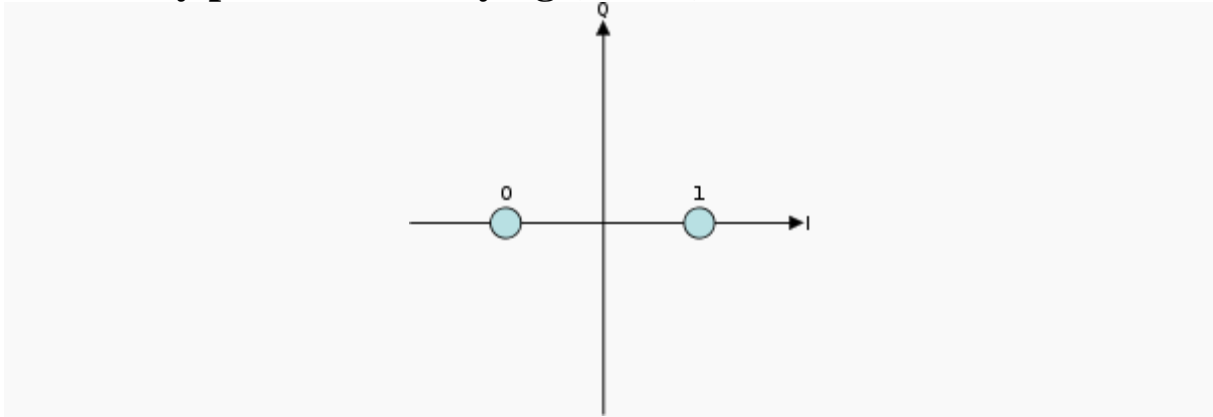

Fig 4.2: Constellation diagram of BPSK

Source : [en.wikipedia.org/wiki/Phase-shift\\_keying](https://en.wikipedia.org/wiki/Phase-shift_keying)

BPSK (also sometimes called PRK, phase reversal keying, or 2PSK) is the simplest form of phase shift keying (PSK). It uses two phases which are separated by  $180^\circ$  and so can also be termed 2-PSK. It does not particularly matter exactly where the constellation points are positioned, and in this figure they are shown on the real axis, at  $0^\circ$  and  $180^\circ$ . This modulation is the most robust of all the PSKs since it takes the highest level of noise or distortion to make the demodulator reach an incorrect decision. It is, however, only able to modulate at 1 bit/symbol (as seen in the figure) and so is unsuitable for high data-rate applications.

In the presence of an arbitrary phase-shift introduced by the communications channel, the demodulator is unable to tell which constellation point is which. As a result, the data is often differentially encoded prior to modulation.

BPSK is functionally equivalent to 2-QAM modulation

## 4.3 Circuit diagram of PSK

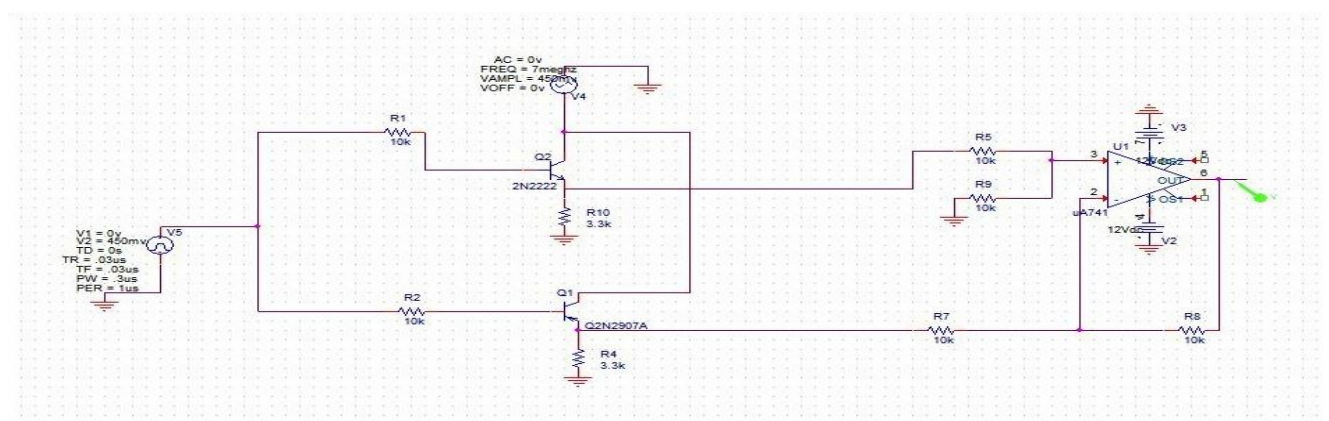

Fig 4.3: Circuit diagram of BPSK

A sine wave of amplitude 5V and 7MHz is fed to the collector of the pnp and npn transistors as carrier and the message signal, a square wave of amplitude 5V and 3MHz is fed to the base of the transistors. The transistors are switched on alternatively and their outputs are summed using an op-amp. The BPSK wave is observed at pin 6 of the op-amp IC 741.

#### 4.4 Simulation in Pspice software

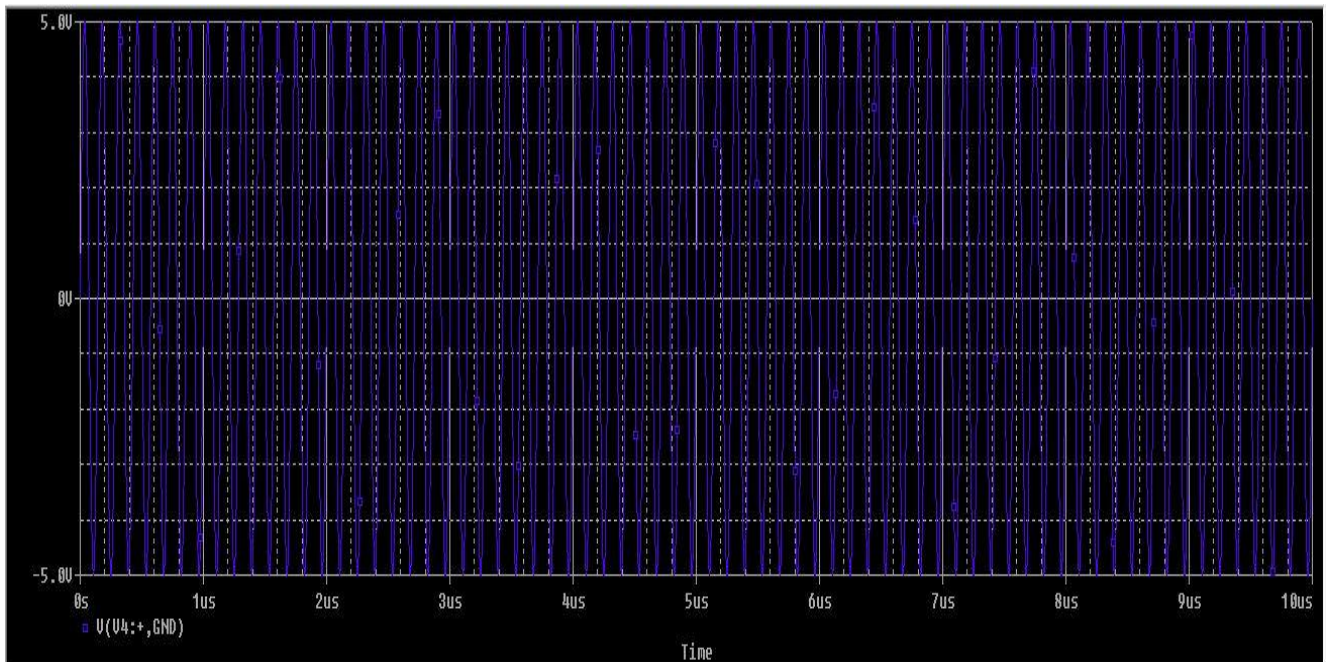

Fig 4.4: Waveforms of carrier

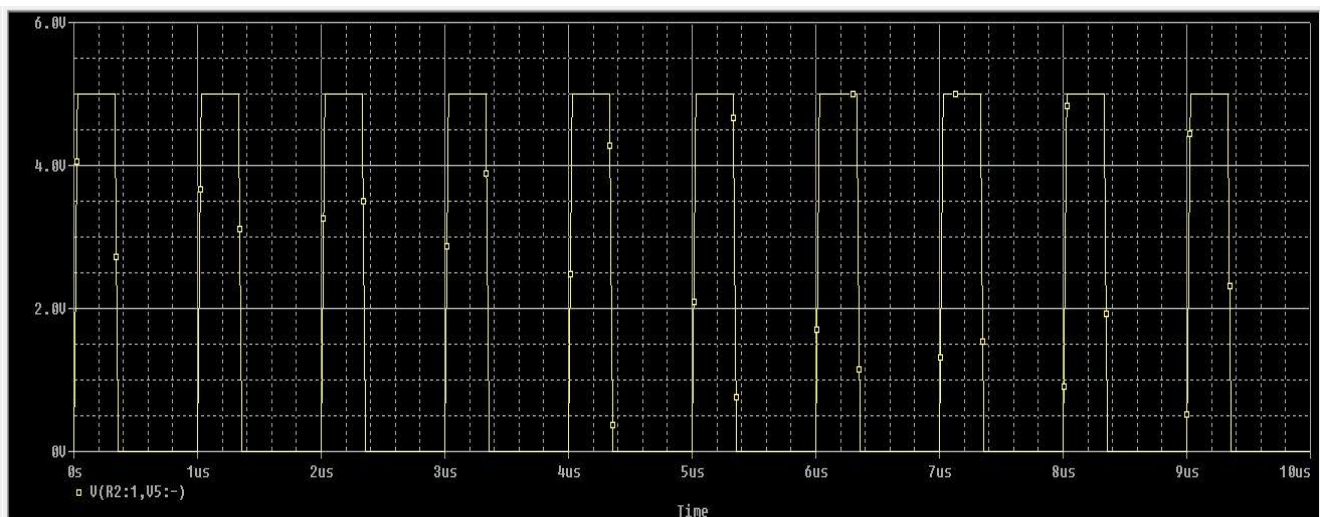

Fig 4.5: Waveforms of input message

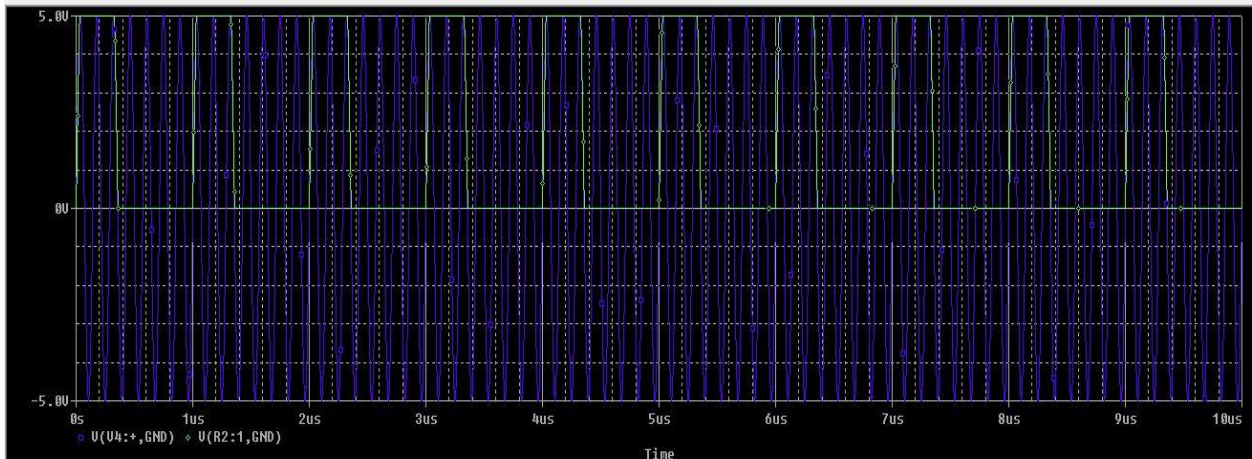

Fig 4.6: Waveforms of input message and carrier

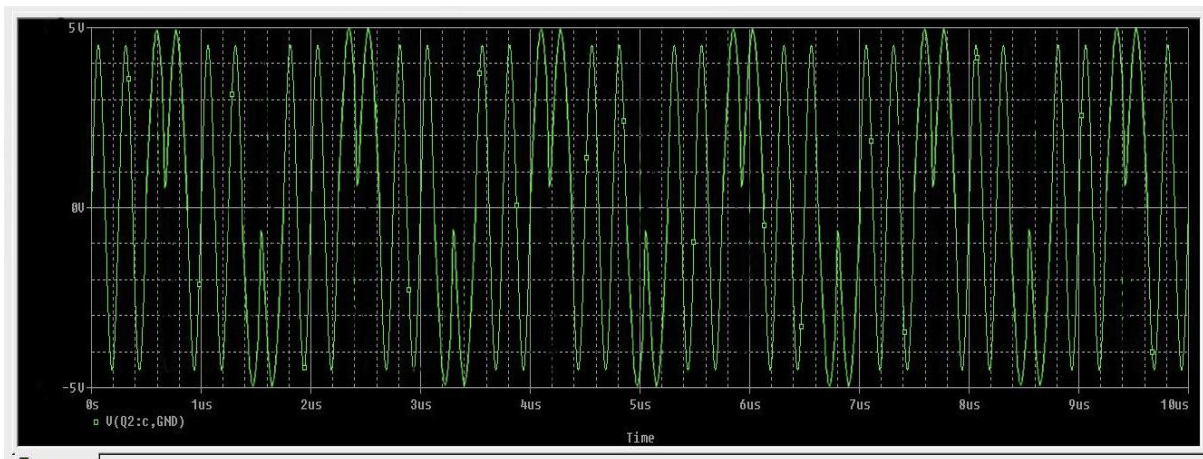

Fig 4.7 : Waveforms of output

## 4.5 Implementation

The general form for BPSK follows the equation:

$$s_n(t) = \sqrt{\frac{2E_b}{T_b}} \cos(2\pi f_c t + \pi(1 - n)), n = 0, 1. \quad [2]$$

This yields two phases, 0 and  $\pi$ . In the specific form, binary data is often conveyed with the following signals:

$$s_0(t) = \sqrt{\frac{2E_b}{T_b}} \cos(2\pi f_c t + \pi) = -\sqrt{\frac{2E_b}{T_b}} \cos(2\pi f_c t) \quad \text{for binary "0" [2]}$$

$$s_1(t) = \sqrt{\frac{2E_b}{T_b}} \cos(2\pi f_c t) \quad \text{for binary "1" [2]}$$

where  $f_c$  is the frequency of the carrier-wave.

Hence, the signal-space can be represented by the single basis function

$$\phi(t) = \sqrt{\frac{2}{T_b}} \cos(2\pi f_c t) \quad [2]$$

where 1 is represented by  $\sqrt{E_b}\phi(t)$  and 0 is represented by  $-\sqrt{E_b}\phi(t)$ . This assignment is, of course, arbitrary.

This use of this basis function is shown at the end of the next section in a signal timing diagram. The topmost signal is a BPSK-modulated cosine wave that the BPSK modulator would produce. The bit-stream that causes this output is shown above the signal (the other parts of this figure are relevant only to QPSK).

## 4.6 Probability of error (BPSK)

The bit error rate (BER) of BPSK in AWGN can be calculated as:

$$P_b = Q\left(\sqrt{\frac{2E_b}{N_0}}\right) \text{ or } P_b = \frac{1}{2} \operatorname{erfc}\left(\sqrt{\frac{E_b}{N_0}}\right) \quad [2]$$

Since there is only one bit per symbol, this is also the symbol error rate.

## 4.7 Quadrature phase shift keying (QPSK)

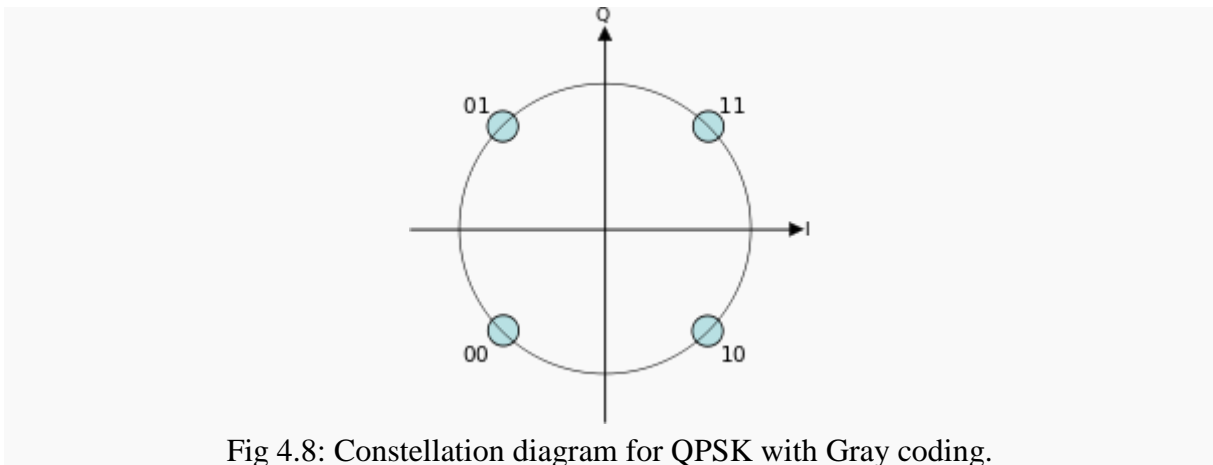

Fig 4.8: Constellation diagram for QPSK with Gray coding.

Source : [en.wikipedia.org/wiki/Phase-shift\\_keying](https://en.wikipedia.org/wiki/Phase-shift_keying)

Each adjacent symbol only differs by one bit.

Sometimes this is known as *quaternary PSK*, *quadriphase PSK*, 4-PSK, or 4-QAM. (Although the root concepts of QPSK and 4-QAM are different, the resulting modulated radio waves are exactly the same.) QPSK uses four points on the constellation diagram, equispaced around a circle. With four phases, QPSK can encode two bits per symbol, shown in the diagram with gray coding to minimize the bit error rate (BER) — sometimes misperceived as twice the BER of BPSK.



The mathematical analysis shows that QPSK can be used either to double the data rate compared with a BPSK system while maintaining the *same* bandwidth of the signal, or to *maintain the data-rate of BPSK* but halving the bandwidth needed. In this latter case, the BER of QPSK is *exactly the same* as the BER of BPSK - and deciding differently is a common confusion when considering or describing QPSK.

Given that radio communication channels are allocated by agencies such as the Federal Communication Commission giving a prescribed (maximum) bandwidth, the advantage of QPSK over BPSK becomes evident: QPSK transmits twice the data rate in a given bandwidth compared to BPSK - at the same BER. The engineering penalty that is paid is that QPSK transmitters and receivers are more complicated than the ones for BPSK. However, with modern electronics technology, the penalty in cost is very moderate.

As with BPSK, there are phase ambiguity problems at the receiving end, and differentially encoded QPSK is often used in practice.

## 4.8 Implementation

The implementation of QPSK is more general than that of BPSK and also indicates the implementation of higher-order PSK. Writing the symbols in the constellation diagram in terms of the sine and cosine waves used to transmit them:

$$s_n(t) = \sqrt{\frac{2E_s}{T_s}} \cos\left(2\pi f_c t + (2n - 1)\frac{\pi}{4}\right), \quad n = 1, 2, 3, 4. \quad [2]$$

This yields the four phases  $\pi/4$ ,  $3\pi/4$ ,  $5\pi/4$  and  $7\pi/4$  as needed.

This results in a two-dimensional signal space with unit basis functions

$$\phi_1(t) = \sqrt{\frac{2}{T_s}} \cos(2\pi f_c t) \quad [2]$$

$$\phi_2(t) = \sqrt{\frac{2}{T_s}} \sin(2\pi f_c t) \quad [2]$$

The first basis function is used as the in-phase component of the signal and the second as the quadrature component of the signal.

Hence, the signal constellation consists of the signal-space 4 points

$$\left(\pm\sqrt{E_s/2}, \pm\sqrt{E_s/2}\right). \quad [2]$$

The factors of 1/2 indicate that the total power is split equally between the two carriers.

Comparing these basis functions with that for BPSK shows clearly how QPSK can be viewed as two independent BPSK signals. Note that the signal-space points for BPSK do not need to split the symbol (bit) energy over the two carriers in the scheme shown in the BPSK constellation diagram.

QPSK systems can be implemented in a number of ways. An illustration of the major components of the transmitter and receiver structure is shown below.

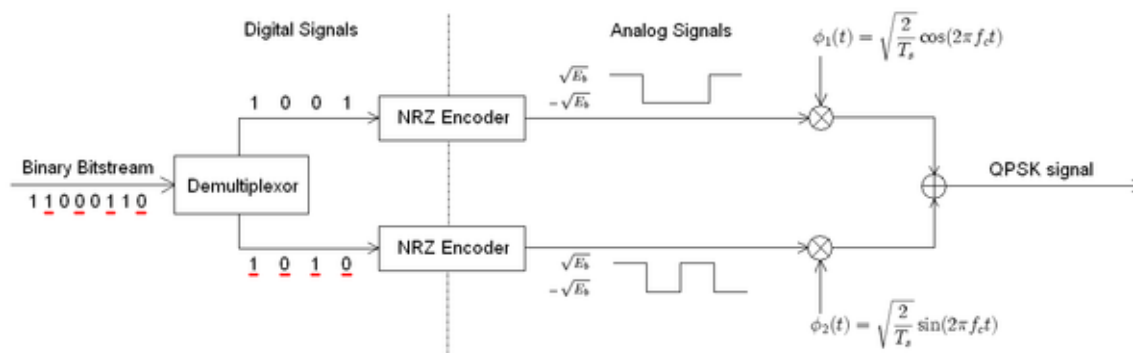

Fig 4.9: Conceptual transmitter structure for QPSK.

Source: [en.wikipedia.org/wiki/Phase-shift\\_keying](https://en.wikipedia.org/wiki/Phase-shift_keying)

The binary data stream is split into the in-phase and quadrature-phase components. These are then separately modulated onto two orthogonal basis functions. In this implementation, two sinusoids are used. Afterwards, the two signals are superimposed, and the resulting signal is the QPSK signal. Note the use of polar non-return-to-zero encoding. These encoders can be placed before for binary data source, but have been placed after to illustrate the conceptual difference between digital and analog signals involved with digital modulation.

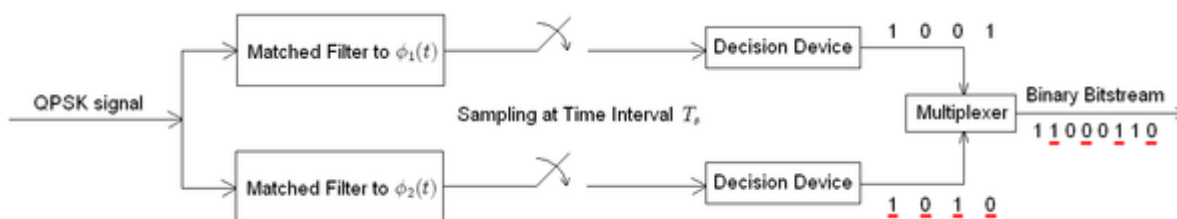

Fig 4.10: Block diagram of QPSK

Source : [en.wikipedia.org/wiki/Phase-shift\\_keying](https://en.wikipedia.org/wiki/Phase-shift_keying)

Receiver structure for QPSK. The matched filters can be replaced with correlators. Each detection device uses a reference threshold value to determine whether a 1 or 0 is detected.

## 4.9 Probability of error (QPSK)

Although QPSK can be viewed as a quaternary modulation, it is easier to see it as two independently modulated quadrature carriers. With this interpretation, the even (or odd) bits are used to modulate the in-phase component of the carrier, while the odd (or even) bits are used to modulate the quadrature-phase component of the carrier. BPSK is used on both carriers and they can be independently demodulated.

As a result, the probability of bit-error for QPSK is the same as for BPSK:

$$P_b = Q\left(\sqrt{\frac{2E_b}{N_0}}\right) \quad [2]$$

However, in order to achieve the same bit-error probability as BPSK, QPSK uses twice the power (since two bits are transmitted simultaneously).

The symbol error rate is given by:

$$P_s = 1 - (1 - P_b)^2$$

$$= 2Q\left(\sqrt{\frac{E_s}{N_0}}\right) - \left[Q\left(\sqrt{\frac{E_s}{N_0}}\right)\right]^2 \quad [2]$$

If the signal-to-noise ratio is high (as is necessary for practical QPSK systems) the probability of symbol error may be approximated:

$$P_s \approx 2Q\left(\sqrt{\frac{E_s}{N_0}}\right) \quad [2]$$

The modulated signal is shown below for a short segment of a random binary data-stream. The two carrier waves are a cosine wave and a sine wave, as indicated by the signal-space analysis above. Here, the odd-numbered bits have been assigned to the in-phase component and the even-numbered bits to the quadrature component (taking the first bit as number 1). The total signal — the sum of the two components — is shown at the bottom. Jumps in phase can be seen as the PSK changes the phase on each component at the start of each bit-period. The topmost waveform alone matches the description given for BPSK above.

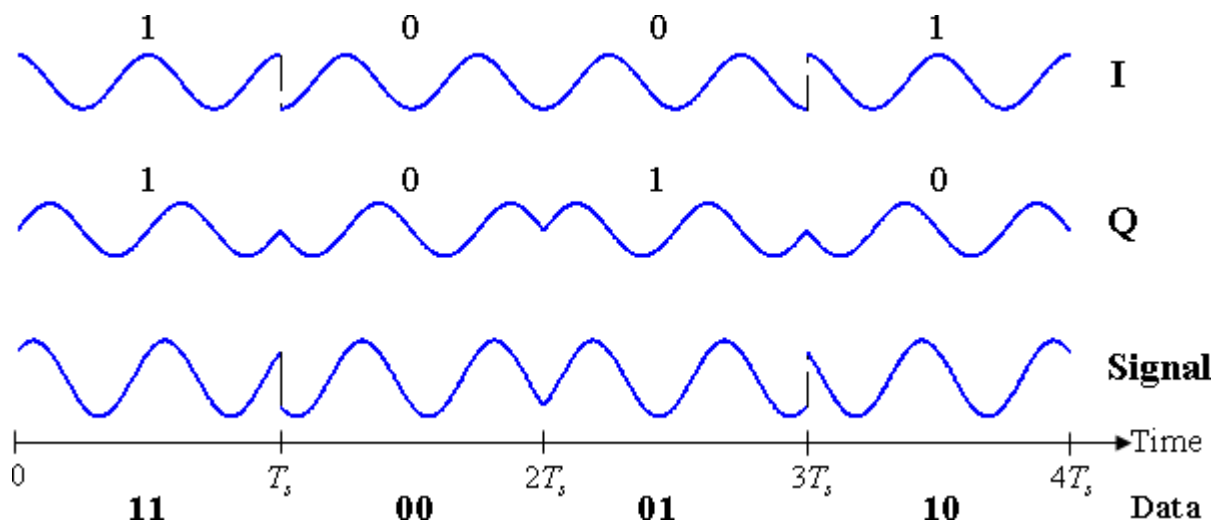

Fig 4.11: Timing diagram for QPSK

Source : [en.wikipedia.org/wiki/Phase-shift\\_keying](https://en.wikipedia.org/wiki/Phase-shift_keying)

The binary data stream is shown beneath the time axis. The two signal components with their bit assignments are shown the top and the total, combined signal at the bottom. Note the abrupt changes in phase at some of the bit-period boundaries.

The binary data that is conveyed by this waveform is: 1 1 0 0 0 1 1 0.

The odd bits, highlighted here, contribute to the in-phase component: **1 1 0 0 0 1 1 0**

The even bits, highlighted here, contribute to the quadrature-phase component: **1 1 0 0 0 1 1 0**

## 4.10 Offset QPSK (OQPSK)

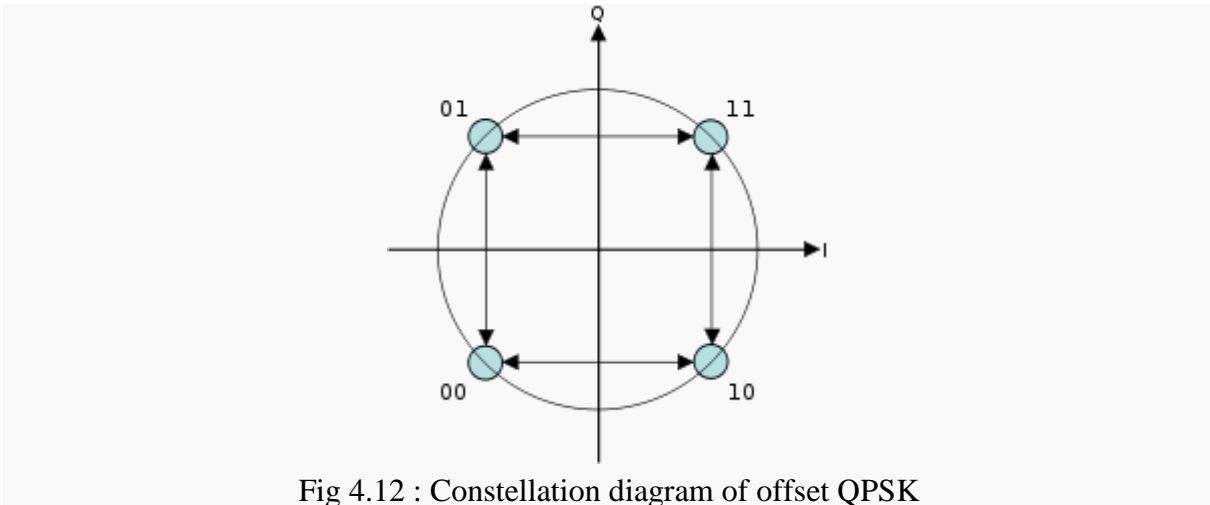

Fig 4.12 : Constellation diagram of offset QPSK

Source : [en.wikipedia.org/wiki/Phase-shift\\_keying](http://en.wikipedia.org/wiki/Phase-shift_keying)

Signal doesn't cross zero, because only one bit of the symbol is changed at a time

*Offset quadrature phase-shift keying (OQPSK)* is a variant of phase-shift keying modulation using 4 different values of the phase to transmit. It is sometimes called *Staggered quadrature phase-shift keying (SQPSK)*.

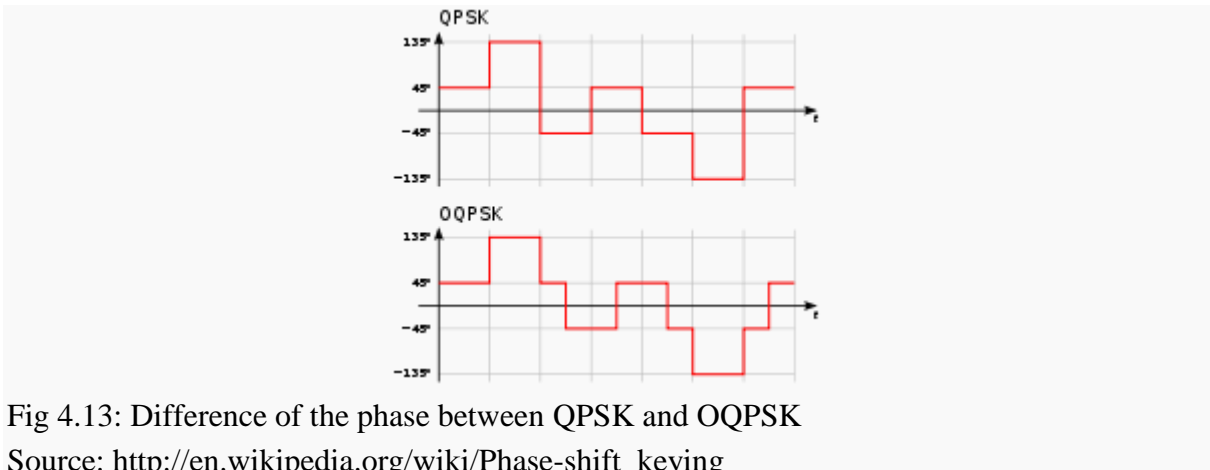

Fig 4.13: Difference of the phase between QPSK and OQPSK

Source: [http://en.wikipedia.org/wiki/Phase-shift\\_keying](http://en.wikipedia.org/wiki/Phase-shift_keying)

Taking four values of the phase (two bits) at a time to construct a QPSK symbol can allow the phase of the signal to jump by as much as  $180^\circ$  at a time. When the signal is passed through a lowpass filter (as is typical in a transmitter), these phase-shifts result in large amplitude fluctuations. These fluctuations affect the quality of the received signal. By offsetting the timing of the odd and even bits by one bit-period, or half a symbol-period, the in-phase and quadrature components will never change at the same time. In the constellation diagram shown on the right, it can be seen that this will limit the phase-shift to no more than  $90^\circ$  at a time. This yields much lower amplitude fluctuations than non-offset QPSK and is sometimes preferred in practice.

The picture on the right shows the difference in the behavior of the phase between ordinary QPSK and OQPSK. It can be seen that in the first plot the phase can change by  $180^\circ$  at once, while in OQPSK the changes are never greater than  $90^\circ$ .



The modulated signal is shown below for a short segment of a random binary data-stream. Note the half symbol-period offset between the two component waves. The sudden phase-shifts occur about twice as often as for QPSK (since the signals no longer change together), but they are less severe. In other words, the magnitude of jumps is smaller in OQPSK when compared to QPSK.

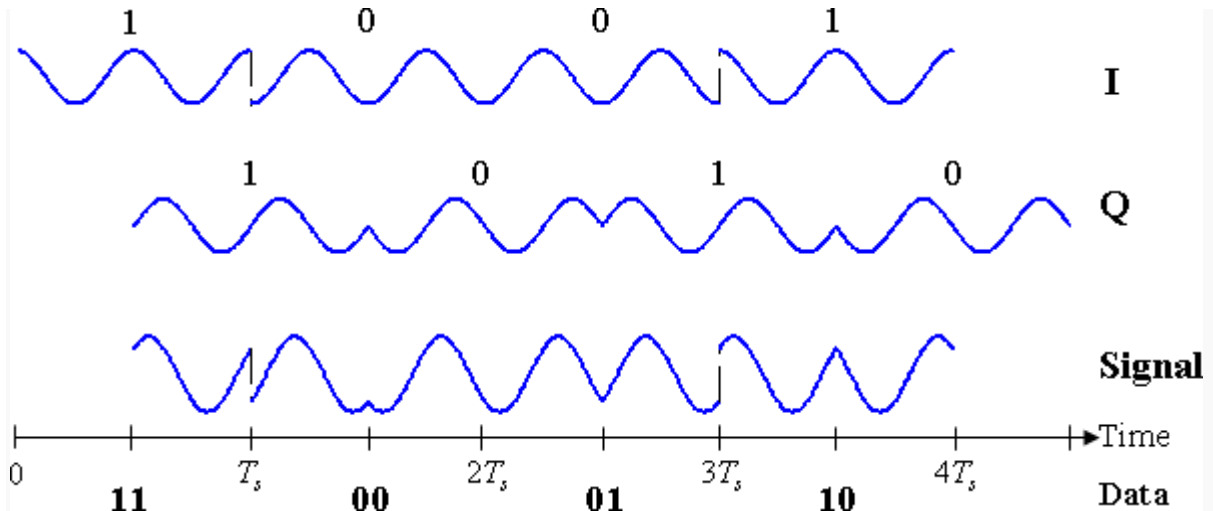

Fig 4.14: Timing diagram for offset-QPSK.

Source: [en.wikipedia.org/wiki/Phase-shift\\_keying](https://en.wikipedia.org/wiki/Phase-shift_keying)

The binary data stream is shown beneath the time axis. The two signal components with their bit assignments are shown the top and the total, combined signal at the bottom. Note the half-period offset between the two signal components.

### 4.11 $\pi/4$ -QPSK

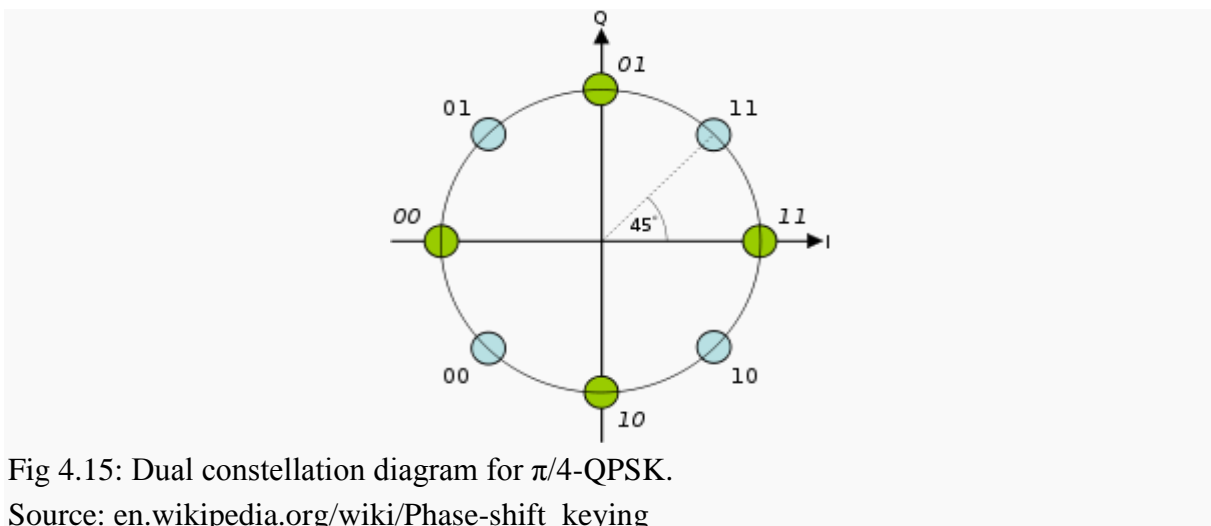

Fig 4.15: Dual constellation diagram for  $\pi/4$ -QPSK.

Source: [en.wikipedia.org/wiki/Phase-shift\\_keying](https://en.wikipedia.org/wiki/Phase-shift_keying)

This shows the two separate constellations with identical gray coding but rotated by  $45^\circ$  with respect to each other.

This variant of QPSK uses two identical constellations which are rotated by  $45^\circ$  ( $\pi/4$  radians, hence the name) with respect to one another. Usually, either the even or odd symbols

are used to select points from one of the constellations or the other symbols select points from the other constellation. This also reduces the phase-shifts from a maximum of  $180^\circ$ , but only to a maximum of  $135^\circ$  and so the amplitude fluctuations of  $\pi/4$ -QPSK are between OQPSK and non-offset QPSK.

One property this modulation scheme possesses is that if the modulated signal is represented in the complex domain, it does not have any paths through the origin. In other words, the signal does not pass through the origin. This lowers the dynamical range of fluctuations in the signal, which is desirable when engineering communications signals.

On the other hand,  $\pi/4$ -QPSK lends itself to easy demodulation and has been adopted for use in, for example, TDMA cellular telephone systems.

The modulated signal is shown below for a short segment of a random binary data-stream. The construction is the same as above for ordinary QPSK. Successive symbols are taken from the two constellations shown in the diagram. Thus, the first symbol (1 1) is taken from the 'blue' constellation and the second symbol (0 0) is taken from the 'green' constellation. Note that magnitudes of the two component waves change as they switch between constellations, but the total signal's magnitude remains constant (constant envelope). The phase-shifts are between those of the two previous timing-diagrams.

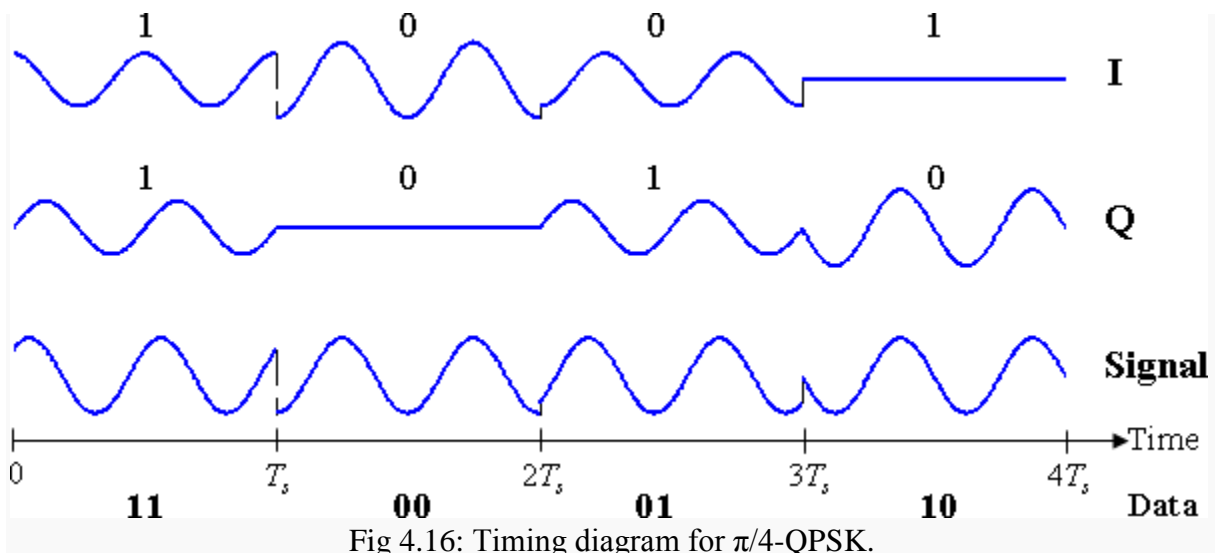

Fig 4.16: Timing diagram for  $\pi/4$ -QPSK.

Source: [en.wikipedia.org/wiki/Phase-shift\\_keying](https://en.wikipedia.org/wiki/Phase-shift_keying)

The binary data stream is shown beneath the time axis. The two signal components with their bit assignments are shown the top and the total, combined signal at the bottom. Note that successive symbols are taken alternately from the two constellations, starting with the 'blue' one.

## 4.12 High order PSK

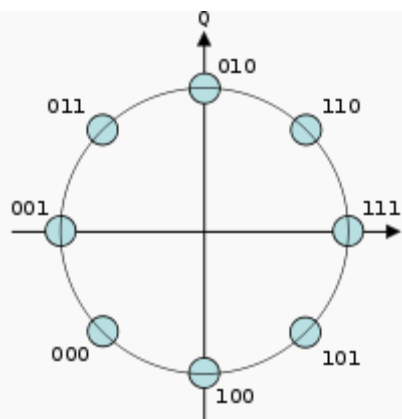

Fig 4.17: Constellation diagram for 8-PSK with Gray coding.

Source: [en.wikipedia.org/wiki/Phase-shift\\_keying](https://en.wikipedia.org/wiki/Phase-shift_keying)

Any number of phases may be used to construct a PSK constellation but 8-PSK is usually the highest order PSK constellation deployed. With more than 8 phases, the error-rate becomes too high and there are better, though more complex, modulations available such as quadrature amplitude modulation (QAM). Although any number of phases may be used, the fact that the constellation must usually deal with binary data means that the number of symbols is usually a power of 2 — this allows an equal number of bits-per-symbol.

## 4.13 Differential phase shift keying (DPSK)

Differential phase shift keying (DPSK) is a common form of phase modulation that conveys data by changing the phase of the carrier wave. As mentioned for BPSK and QPSK there is an ambiguity of phase if the constellation is rotated by some effect in the communications channel through which the signal passes. This problem can be overcome by using the data to *change* rather than *set* the phase.

For example, in differentially encoded BPSK a binary '1' may be transmitted by adding  $180^\circ$  to the current phase and a binary '0' by adding  $0^\circ$  to the current phase. Another variant of DPSK is Symmetric Differential Phase Shift keying, SDPSK, where encoding would be  $+90^\circ$  for a '1' and  $-90^\circ$  for a '0'.

In differentially encoded QPSK (DQPSK), the phase-shifts are  $0^\circ$ ,  $90^\circ$ ,  $180^\circ$ ,  $-90^\circ$  corresponding to data '00', '01', '11', '10'. This kind of encoding may be demodulated in the same way as for non-differential PSK but the phase ambiguities can be ignored. Thus, each received symbol is demodulated to one of the M points in the constellation and a comparator then computes the difference in phase between this received signal and the preceding one. The difference encodes the data as described above. Symmetric Differential Quadrature Phase Shift Keying (SDQPSK) is like DQPSK, but encoding is symmetric, using phase shift values of  $-135^\circ$ ,  $-45^\circ$ ,  $+45^\circ$  and  $+135^\circ$ .

The modulated signal is shown below for both DBPSK and DQPSK as described above. In the figure, it is assumed that the *signal starts with zero phases*, and so there is a phase shift in both signals at  $t = 0$ .

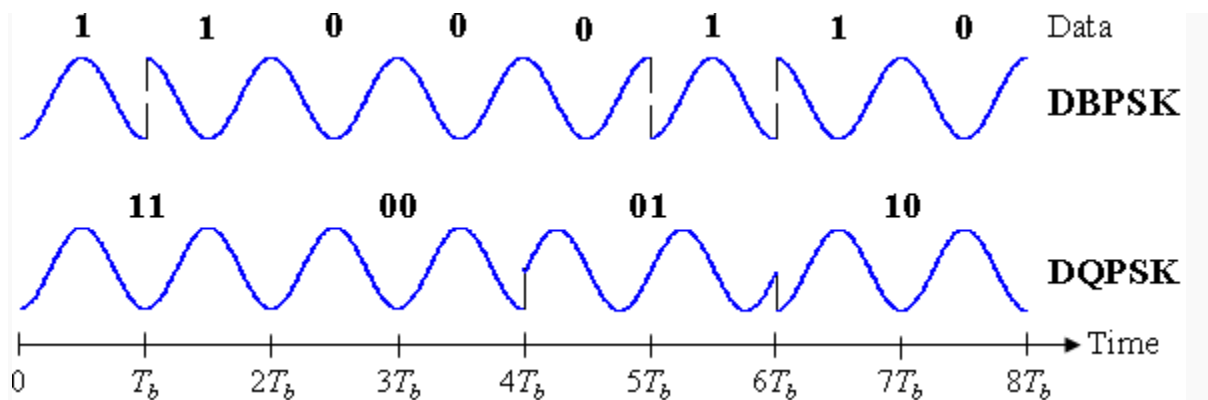

Fig 4.18: Timing diagram for DBPSK and DQPSK.

Source : [en.wikipedia.org/wiki/Phase-shift\\_keying](https://en.wikipedia.org/wiki/Phase-shift_keying)

The binary data stream is above the DBPSK signal. The individual bits of the DBPSK signal are grouped into pairs for the DQPSK signal, which only changes every  $T_s = 2T_b$ .

Analysis shows that differential encoding approximately doubles the error rate compared to ordinary  $M$ -PSK but this may be overcome by only a small increase in  $E_b/N_0$ . Furthermore, this analysis (and the graphical results below) are based on a system in which the only corruption is additive white Gaussian noise (AWGN). However, there will also be a physical channel between the transmitter and receiver in the communication system. This channel will, in general, introduce an unknown phase-shift to the PSK signal.

## 4.14 Demodulation

Demodulation is the act of extracting the original information-bearing signal from a modulated carrier wave. A demodulator is an electronic circuit (or computer program in a software-defined radio) that is used to recover the information content from the modulated carrier wave. The demodulator takes the digital data and, using the staircase maker and the delay unit, creates the analog signal. The created analog signal, however, needs to pass through a low-pass filter for smoothing.

These terms are traditionally used in connection with radio receivers, but many other systems use many kinds of demodulators. Another common one is in a modem, which is a contraction of the terms modulator/demodulator.

There are several ways of demodulation depending on how parameters of the base-band signal are transmitted in the carrier signal, such as amplitude, frequency or phase. For example, for a signal modulated with a linear modulation, like AM (amplitude modulation), we can use a synchronous detector. On the other hand, for a signal modulated with an angular modulation, we must use an FM (frequency modulation) demodulator or a PM (phase modulation) demodulator. Different kinds of circuits perform these functions.

Many techniques, such as carrier recovery, clock recovery, bit slip, frame synchronization, rake receiver, pulse compression, Received Signal Strength Indication, error detection and

correction, etc., are only performed by demodulators, although any specific demodulator may perform only some or none of these techniques.

Many things can act as a demodulator, if they pass the radio waves on nonlinearly: for example, near a powerful radio station, it has been known for the metal sides of a van to demodulate the radio signal as sound.

### 4.15 Demodulation of Phase Shift Keying

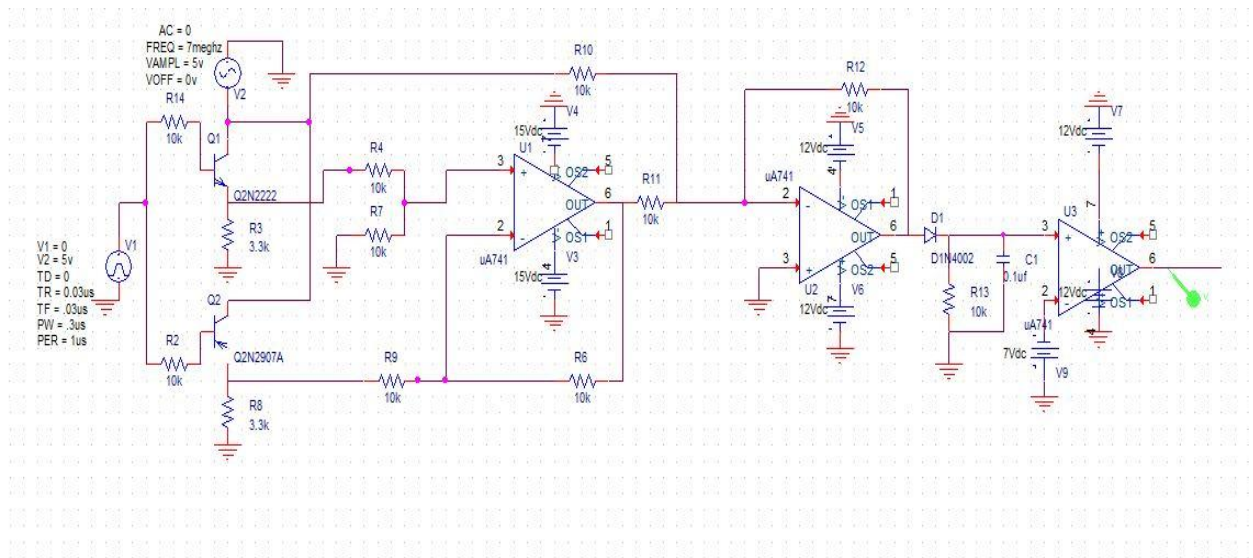

Fig 4.19: Circuit diagram modulation and demodulation

The modulated wave and carrier is summed up and inverted firstly. Then the diode clips 0 part and allow only 1 part. Then it's filtered by low pass filter, which is made by RC circuit. And finally comparator compares the output with reference voltage 7V and gives output. The output we get is same signal that we have fed in input but little change in magnitude.

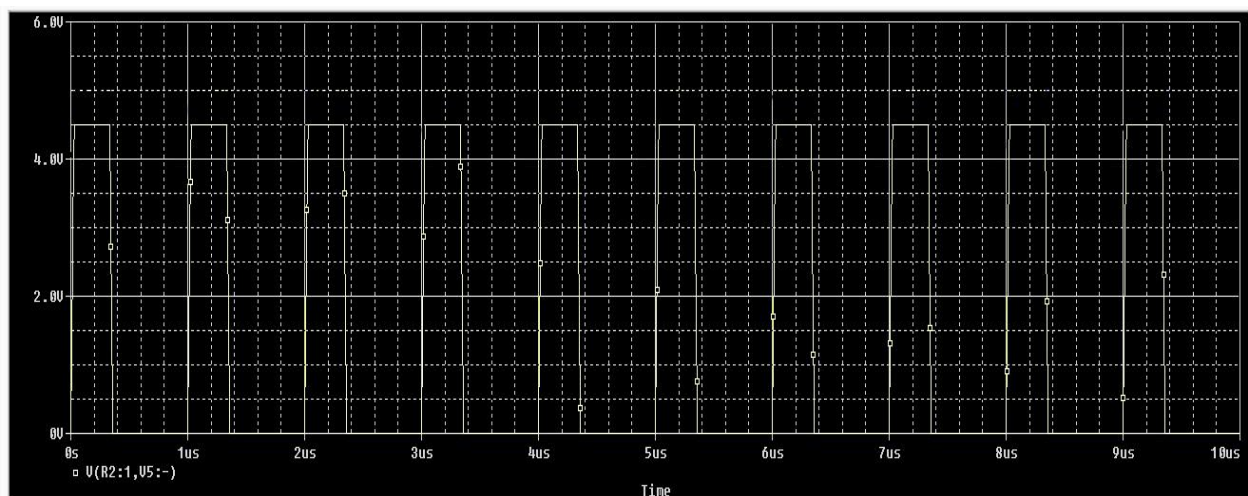

Fig 4.20: Resultant waveform after demodulation

## 4.16 Applications

PSK is simple to design, particularly when compared with its competitor quadrature amplitude modulation, it is widely used in existing technologies.

The wireless LAN standard, IEEE 802.11b-1999, uses a variety of different PSKs depending on the bitrate required. At the basic-rate of 1 Mbit/s, it uses DBPSK (differential BPSK). To provide the extended-rate of 2 Mbit/s, DQPSK is used. In reaching 5.5 Mbit/s and the full-rate of 11 Mbit/s, QPSK is employed, but has to be coupled with complementary code keying. The higher-speed wireless LAN standard, IEEE 802.11g-2003 has eight data rates: 6, 9, 12, 18, 24, 36, 48 and 54 Mbit/s. The 6 and 9 Mbit/s modes uses OFDM modulation where each sub-carrier is BPSK modulated. The 12 and 18 Mbit/s modes use OFDM with QPSK. The fastest four modes use OFDM with forms of quadrature amplitude modulation.

As BPSK is easy to implement, it is appropriate for low-cost passive transmitters, and is used in RFID standards such as ISO/IEC 14443 which has been adopted for biometric passports, credit cards such as American Express's express pay, and many other applications.

Bluetooth 2 will use  $\pi/4$ -DQPSK at its lower rate (2 Mbit/s) and 8-DPSK at its higher rate (3 Mbit/s) when the link between the two devices is sufficiently robust. Bluetooth 1 modulates with Gaussian minimum-shift keying, a binary scheme, so either modulation choice in version 2 will yield a higher data-rate. A similar technology, IEEE 802.15.4 also relies on PSK. IEEE 802.15.4 allows the use of two frequency bands: 868–915 MHz using BPSK and at 2.4 GHz using OQPSK.

Notably absent from these various schemes is 8-PSK. This is because its error-rate performance is close to that of 16-QAM — it is only about 0.5 dB better but its data rate is only three-quarters that of 16-QAM. Thus 8-PSK is often omitted from standards and, as seen above, schemes tend to 'jump' from QPSK to 16-QAM (8-QAM is possible but difficult to implement).

Included among the exceptions is Hughes Net satellite ISP. For example, the model HN7000S modem (on KU-band satcom) uses 8-PSK modulations.



# Hardware Implementation

Implemented circuit for ASK, FSK, PSK

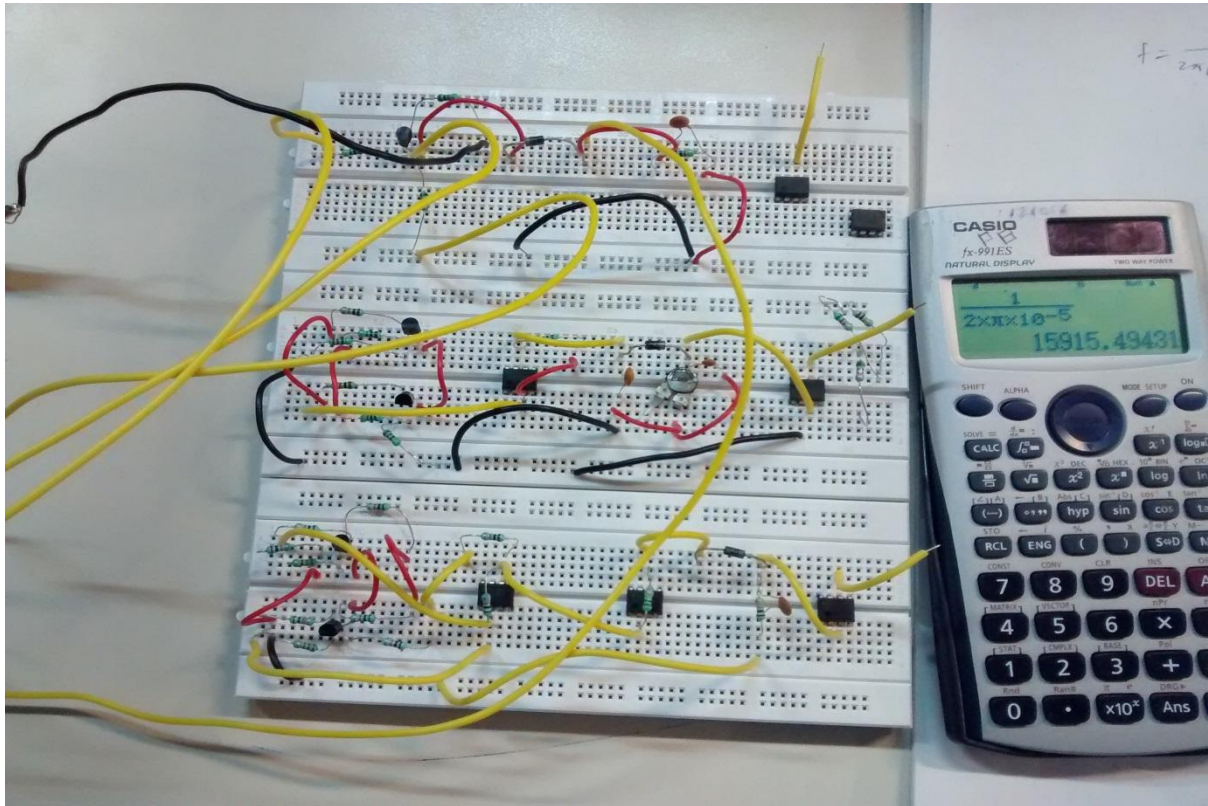

Input saw tooth waveform.

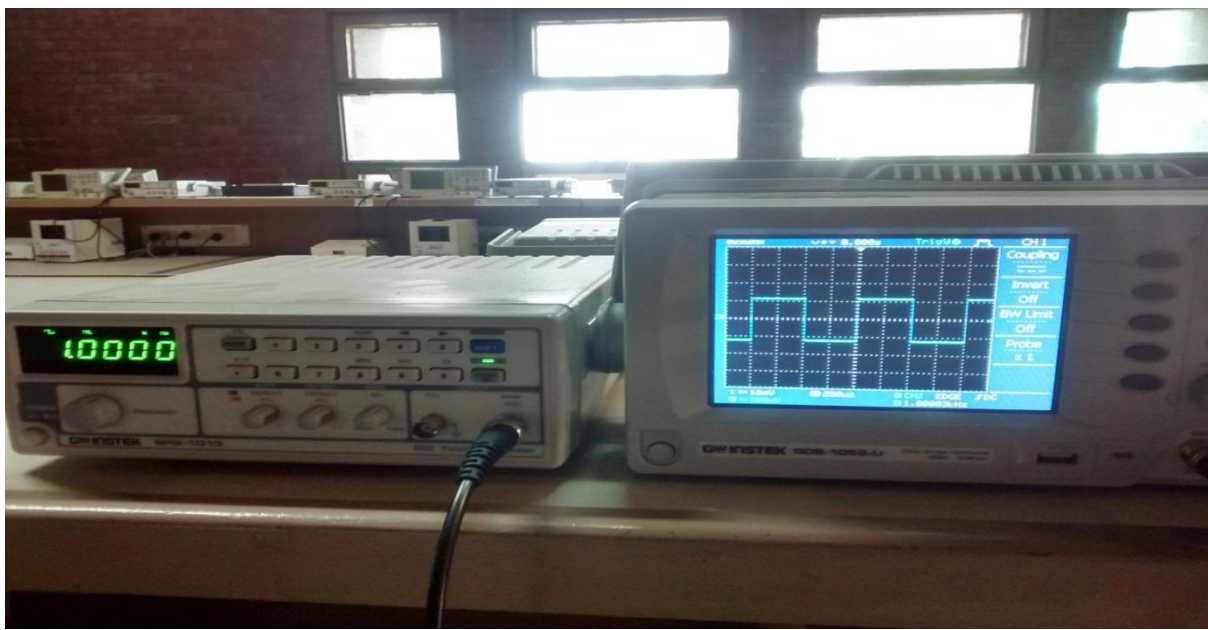

ASK Modulation.

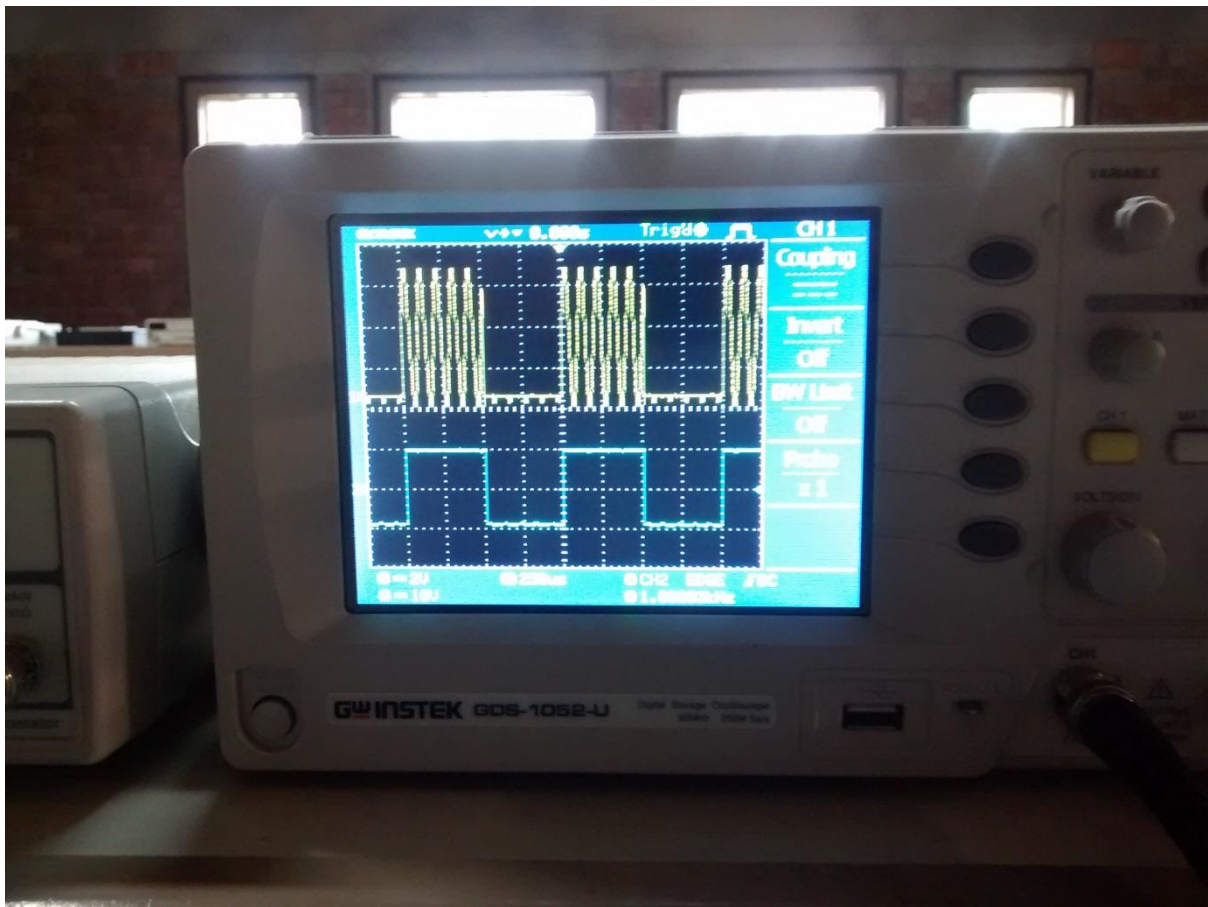

ASK Demodulation

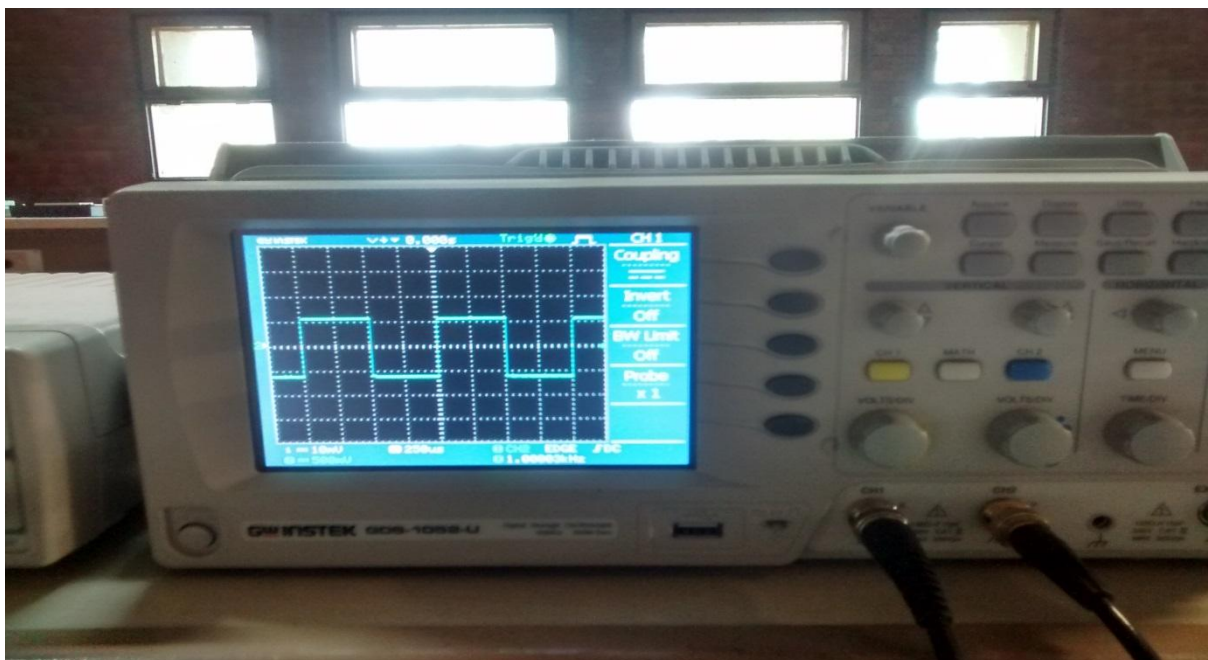



FSK waveform

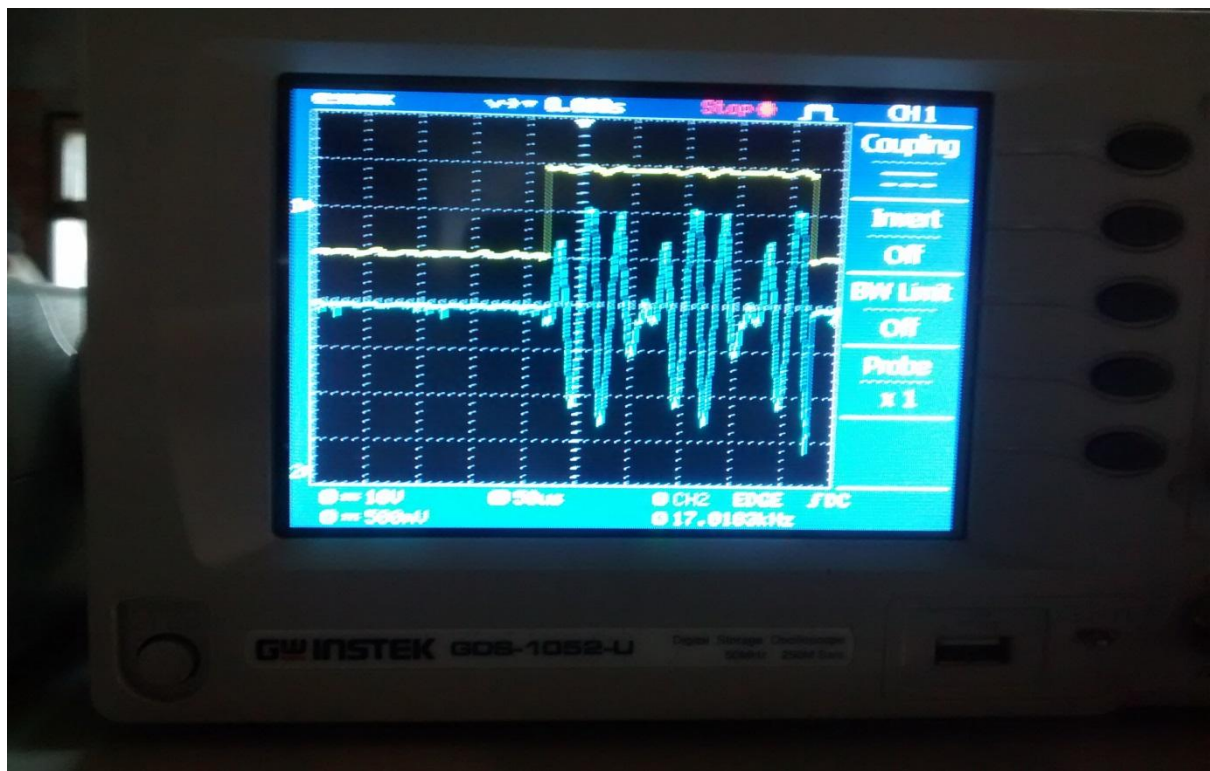

PSK waveform

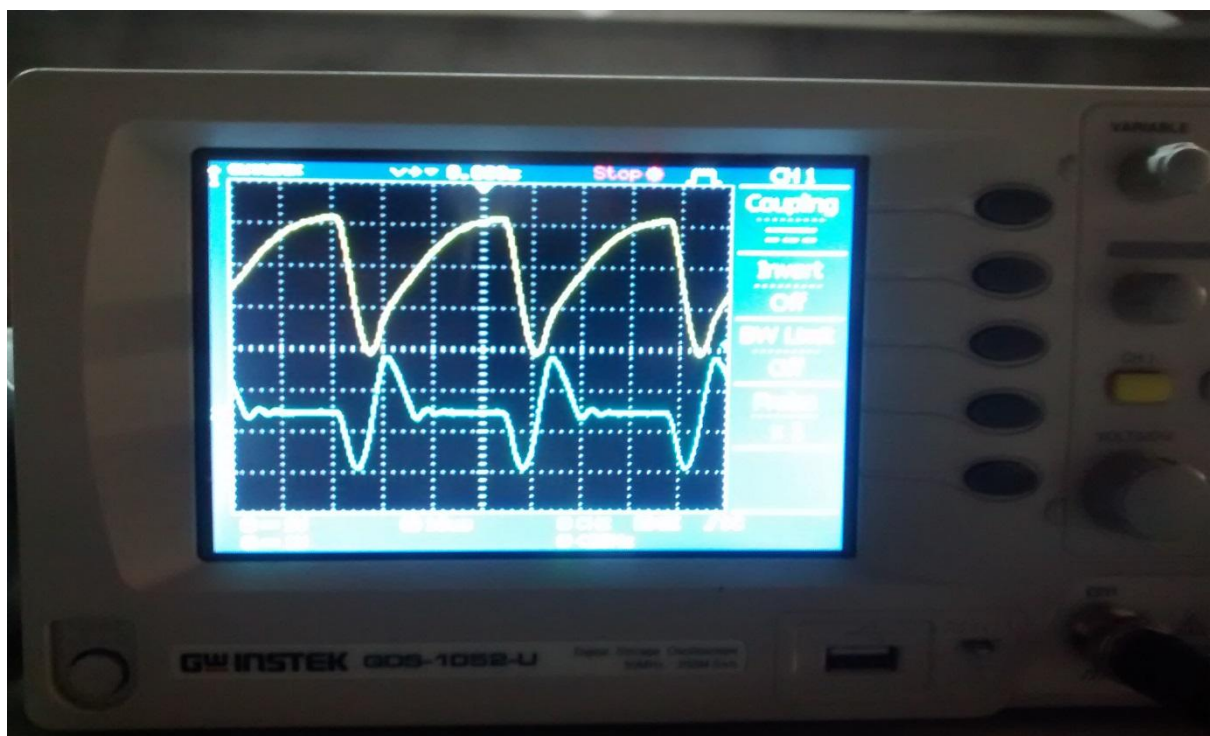

## **Conclusion**

Working on this project taught me to adopt a methodical approach to problem solving. From the outset of the project the aim was to design and simulate a complete modulation and demodulation of the Digital Modulation Techniques.

Knowledge of analogue design of circuits greatly helped in the design of the project. DC formulae and circuits configurations studied in the process of three years of Electronics gave good background knowledge of the type of circuits to be implemented in modulation of PSK. Another aspect that helped was the previous use of the Pspice simulation package. Now having spent the duration of the project working with Pspice, we would have to say that our knowledge of the package has been greatly enhanced, as too is our understanding of digital modulation and other circuits in general.

## References

- A.Bruce Carlson -communication system.
- D.C Kulshreshtha-Electronics Engineering.
- B.P Lathi.Modern Digital and Analog communication systems

[1]: [en.wikipedia.org/wiki/Amplitude-shift keying](http://en.wikipedia.org/wiki/Amplitude-shift_keying)

[2]: [http://en.wikipedia.org/wiki/Phase-shift\\_keying](http://en.wikipedia.org/wiki/Phase-shift_keying)

## **Appendix: software used**

- i. OrCAD Capture CSI lite 16.6- By Cadence Design System, Inc.
- ii. Microsoft Office Word 2007
- iii. Microsoft Windows 7 (Build 7600)
- iv. LTspice IV (64-Bit)