

CELL PHONE CONTROLLED SURVEILLANCE ROBOT

Submitted in partial fulfillment of the Degree of
Bachelor of Technology



May – 2015

Students : Gaurank Srivastava (111017)
Akriti Saini (111098)
Anchit Bhardwaj (111138)

Supervisor : Davinder Singh Saini
Associate Professor

DEPARTMENT OF ELECTRONICS AND COMMUNICATION ENGINEERING

JAYPEE UNIVERSITY OF INFORMATION TECHNOLOGY,

WAKNAGHAT

TALBLE OF CONTENTS

Chapter No.	Topics	Page No.
	CERTIFICATE	I
	ABSTRACT	II
	ACKNOWLEDGEMENT	III
	List of Figures	IV
	List of Tables	V
Chapter-1	Introduction	1
Chapter-2	Technical Details	4
	2.1 Component Description	4
	2.1.1 DTMF Decoder - MT8870	5
	2.1.2 Microcontroller - ATmega16	7
	2.1.3 Motor Driver - L293D	11
	2.1.4 Power Supply	13
	2.1.5 Other Components	17
	2.2 Block Diagram	21
	2.3 Circuit Diagram	21
Chapter-3	Software and Coding	22
	3.1 Atmel Studio	22
	3.2 AVRDUDE	26
	3.3 PCB Wizard	28
	3.4 Programming	31
Chapter-4	Methodology	34
	4.1 Testing	34
	4.2 Circuit Designing	35
	4.3 Printing & Etching	38
	4.4 Soldering	39
	4.5 Assembling	41
	4.6 Working	42
	Results	45
	Applications	45
	Future Work	45
	Challenges	45
	Conclusion	46
	References	46

CERTIFICATE

This is to certify that project report entitled “**Cell Phone Controlled Surveillance Robot**”, submitted by **Gaurank Srivastava (111017)**, **Akriti Saini (111098)** and **Anchit Bhardwaj (111138)** in partial fulfillment for the award of degree of Bachelor of Technology in Electronics & Communication Engineering to Jaypee University of Information Technology, Waknaghat, Solan has been carried out under my supervision.

This work has not been submitted partially or fully to any other University or Institute for the award of this or any other degree or diploma.

Date: 25-5-15

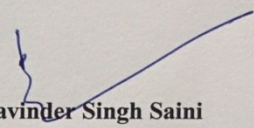
Davinder Singh Saini
Associate Professor
Department of ECE

ABSTRACT

The project is designed to develop a robotic vehicle controlled by the cell phone using DTMF technology. An ATmega16 series of microcontroller is used for the desired operation.

At the transmitting end using the dial pad of the cell phone, commands are sent to the receiver to control the movement of the robot either to move forward, backward and left or right etc. At the receiving end two motors are interfaced to the microcontroller where they are used for the movement of the vehicle. The cell phone acts as a remote control, while the receiver decodes the received DTMF tones before feeding it to the microcontroller to drive DC motors via motor driver IC for necessary work.

Further the project is enhanced by using Skype Video calling technique to control the movement of the robot remotely by watching it on a screen.

Gaurank

Signature of Student

Name GAURANK SRIVASTAVA

Date 25-5-15

[Signature]

Signature of Supervisor

Name DAVINDER SINGH SAINI

Date 25-5-15

Akriti

Signature of Student

Name AKRITI SAINI

Date 25-5-15

Anchit

Signature of Student

Name ANCHIT BHARDWAJ

Date 25-5-15

ACKNOWLEDGEMENT

First and foremost, our sincere thanks to **Prof. Dr. Sunil Bhooshan**, Professor and Head of the department of Electronics and Communication Engineering, Jaypee University of Information Technology, Waknaghat, Solan for providing this opportunity to carry out the present project work and for her encouragement and advice during the course of this work.

We indebted to our internal project guide **Davinder Singh Saini**, Associate Professor of Electronics and Communication Engineering, for his excellent guidance, constant inspiration and encouragement in the completion of this dissertation.

We would like to express our thanks to all the Faculty members, Staff of Department of Electronics & Communication Engineering, who have rendered valuable help in making this project a successful one.

Date:

Gaurank Srivatava
Akriti Saini
Anchit Bhardwaj

List of Figures

S.No.	Title	Page No.
1.	<i>Figure 1 : CM8870 Pin Description</i>	5
2.	<i>Figure 2 : ATmega16 Pin Description</i>	8
3.	<i>Figure 3 : L293D Pin Description</i>	11
4.	<i>Figure 4 : Transformer</i>	13
5.	<i>Figure 5 : Rectification Operation</i>	14
6.	<i>Figure 6 : Output Smoothing of Rectifier</i>	15
7.	<i>Figure 7 : Regulator</i>	15
8.	<i>Figure 8 : Power Supply Circuit Diagram</i>	16
9.	<i>Figure 9 : Robot Block Diagram</i>	20
10.	<i>Figure 10 : Robot Circuit Diagram</i>	20
11.	<i>Figure 11 : Atmel Studio</i>	21
12.	<i>Figure 12 : AVRDUDE</i>	25
13.	<i>Figure 13 : PCB Wizard</i>	27
14.	<i>Figure 14 : Circuit Testing on Breadboard</i>	34
15.	<i>Figure 15 : PCB Etching</i>	38
16.	<i>Figure 16 : PCB Soldering</i>	39
17.	<i>Figure 14 : PCBs Assembling</i>	40

List of Tables

S.No.	Title	Page No.
1.	<i>Table 1 : DTMF</i>	3
2.	<i>Table 2 : CM8870 Pin Functions</i>	6
3.	<i>Table 3 : L293D Pin Description</i>	12

CHAPTER 1

Introduction

Conventionally, Wireless-controlled robots use RF circuits, which have the drawbacks of limited working range, limited frequency range and the limited control. Use of a mobile phone for robotic control can overcome these limitations. It provides the advantage of robust control, working range as large as the coverage area of the service provider, no interference with other controllers and up to twelve controllers.

Although the appearance and the capabilities of robots vary vastly, all robots share the feature of a mechanical, movable structure under some form of control. The Control of robot involves three distinct phases: perception, processing and action. Generally, the preceptors are sensors mounted on the robot, processing is done by the on-board microcontroller or processor, and the task is performed using motors or with some other actuators.

In this project the robot, is controlled by a mobile phone that makes call to the mobile phone attached to the robot in the course of the call, if any button is pressed control corresponding to the button pressed is heard at the other end of the call. The tone is called DTMF(Dual Tone Multi Frequency). The received tone is processed by the atmega16 microcontroller with the help of DTMF decoder MT8870 the decoder decodes the DTMF tone in to its equivalent binary digit and is send to the microcontroller. Output from port pins of microcontroller ATMEGA16 are fed as input to motor driver L293d to drive geared motors.

The important components of this robot are DTMF decoder, Microcontroller and motor driver. A CM8870 series DTMF decoder is used here. All types of the CM8870 series use digital counting techniques to detect and decode all the sixteen DTMF tone pairs in to a four bit code output. The built-in dial tone rejection circuit eliminated the need for pre-filtering.

In this project the robot, is controlled by a mobile phone that makes call to the mobile phone attached to the robot in the course of the call, if any button is pressed control corresponding to the button pressed is heard at the other end of the call. This tone is called dual tone multi frequency tone(DTMF), the robot receives this DTMF tone with the help of phone stacked in the robot.

The received tone is processed by the ATMEGA16 microcontroller with the help of DTMF decoder CM8870. The decoder decodes the DTMF tone in to its equivalent binary digit and this binary number is sent to the microcontroller, the microcontroller is pre-programmed to take a decision for any given input and output's its decision to motor drivers in order to drive the motors for forward or backward motion or a turn.

The mobile that makes a call to the mobile phone stacked in the robot acts as a remote. So this simple robotic project does not require the construction of receiver and transmitter units.

DTMF signaling is used for telephone signaling over the line in the voice frequency band to the call switching center. The version of DTMF used for telephone dialing is known as touch tone.

DTMF assigns a specific frequency (consisting of two separate tones) to each key's that it can easily be identified by the electronic circuit. The signal generated by the DTMF encoder is the direct algebraic submission, in real time of the amplitudes of two sine(or cosine) waves of different frequencies, i.e. ,pressing 5 will send a tone made by adding 1336hz and 770hz to the other end of the mobile. The tones and assignments in a DTMF system shown below:

Frequencies	1209 Hz	1336 Hz	1477 Hz	1633 Hz
697 Hz	1	2	3	A
770 Hz	4	5	6	B
852 Hz	7	8	9	C
941 Hz	*	0	#	D

Table 1 : DTMF

When the input signal given at pin2 (IN-) single ended input configuration is recognized to be effective, the correct four bit decode signal of the DTMF tone is transferred to Q1 (pin11) through Q4(pin14) outputs to microcontroller unit.

The resulting architecture is more code efficient. Outputs from port pins PD0 through PD3 and PD7 of the microcontroller are fed to inputs IN1 through IN4 and enable pins (EN1 and EN2) of motor driver L293D respectively, to drive geared motors.

In order to control the robot, you have to make a call to the cell phone attached to the robot from any phone. Now the phone is picked by the phone on the robot through auto answer mode (which is in the phone, just enable it).

Now when you press 2 the robot will move forward, when you press 4 the robot will move left, when you press 8 the robot will move backwards, when you press 6 the robot will move right, when you press 5 the robot will stop.

CHAPTER 2

Technical Details

2.1 Component Description

The components used in circuit are listed below :

CM8870 DTMF DECODER	1
ATMEGA16 Microcontroller	1
L293D Motor Driver IC	1
7805 Voltage Regulator	2
100K resistances	2
10K resistances	5
330K resistances	1
0.1uF capacitors	2
22pF capacitors	4
3.57MHz crystal	1
12MHz crystal	1
Push to on switch	1
2 geared motors (6v, 50 rpm)	2 (4 for four wheel drive)
Battery 9V	3
Wheels	4
LEDs	5
Cell phone	2 (On board and one as remote)
Headphone jack	1 (for the phone on the rover)

2.1.1 DTMF Decoder - MT8870 / CM8870

The CM8870/MT8870D/MT8870D-1 is an 18 pin IC which is a complete DTMF receiver integrating both the band split filter and digital decoder functions. The filter section uses switched capacitor techniques for high and low group filters; the decoder uses digital counting techniques to detect and decode all 16 DTMF tone-pairs into a 4-bit code.

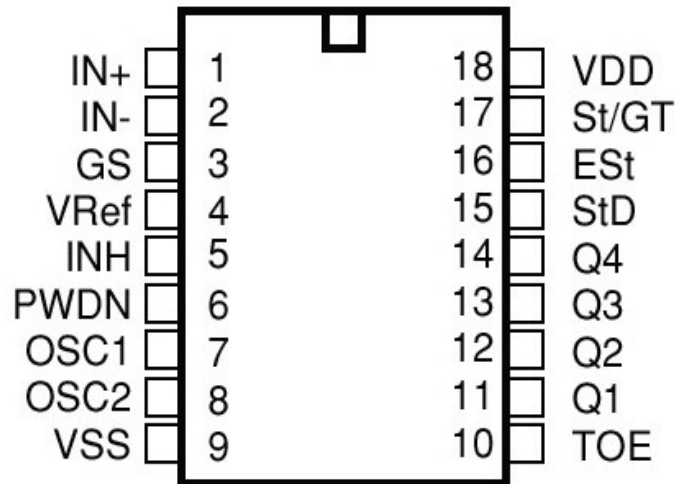

Figure 1 : CM8870 Pin Description

The CM8870/MT8870D/MT8870D-1 monolithic DTMF receiver offers small size, low power consumption and high performance. Its architecture consists of a band split filter section, which separates the high and low group tones, followed by a digital counting section which verifies the frequency and duration of the received tones before passing the corresponding code to the output bus.

Features:

- Complete DTMF Receiver
- Low power consumption
- Internal gain setting amplifier

- Adjustable guard time
- Central office quality
- Power-down mode
- Inhibit mode
- Backward compatible with CM8870/MT8870C/MT8870C-1

Table 2 : CM8870 Pin Functions

Pin Function		
Name	Function	Discription
IN+	Non-inverting input	Connection to the front-end differential amplifier
IN-	Inverting input	Connection to the front-end differential amplifier
GS	Gain select	Gives access to output of front-end differential amplifier for connection of feedback resistor.
V _{REF}	Reference output Voltage (nominally V _{DD} /2)	May be used to bias the inputs at mid-rail.
INH	Inhibits detection of tones	Represents keys A, B, C, and D
OSC3	Digital buffered oscillator output	
PD	Power down	Logic high powers down the device and inhibits the oscillator.
OSC1	Clock input	3.579545MHz crystal connected between these pins completes internal oscillator
OSC2	Clock output	3.579545MHz crystal connected between these pins completes internal oscillator
V _{SS}	Negative power supply	Normally connected to 0V
TOE	Three-state output enable (Input)	Logic high enables the outputs Q1-Q4. Internal pull-up.
Q1 Q2 Q3 Q4	Three-state outputs	When enabled by TOE, provides the code corresponding to the last valid tone pair received. (See Figure 2).
StD	Delayed Steering output	Presents a logic high when a received tone pair has been registered and the output latch is updated. Returns to logic low shen the voltage on St/GT falls below V _{TSt} .
Est	Early steering output	Presents logic high immediately when the digital algorithm detects a recognizable tone pair (signal condition). Any momentary loss of signal condition will cause Est to return to a logic low.
St/Gt	Steering input/guard time output (bidirectional)	A voltage greater than V _{TSt} detected at St causes the device to register the dectected tone pair. The GT output acts to reset the external steering time constraint, and its state is a function of Est and the voltage on St. (See Figure 2).
V _{DD}	Positive power supply	

2.1.2 Microcontroller - ATmega16

Advanced RISC Architecture

- 131 Powerful Instructions - Most Single Clock Cycle Execution
- 32 x 8 General Purpose Working Registers
- Up to 6 MIPS Throughput at 16MHz
- Fully Static Operation
- On-chip 2-cycle Multiplier

Non-volatile Program and Data Memories

- 16k Bytes of In-System Self-Programmable Flash
- Optional Boot Code Section with Independent Lock Bits
- 512K Bytes EEPROM
- Programming Lock for Software Security

Peripheral Features

- On-chip Analog Comparator
- Master/Slave SPI Serial Interface
- Two 8-bit Timer/Counters; One 16-bit Timer/Counter
- Real Time Counter with Separate Oscillator
- Four PWM Channels
- 8-channel, 10-bit ADC
- Byte-oriented Two-wire Serial Interface
- Programmable Serial USART

Special Microcontroller Features

- Power-on Reset and Programmable Brown-out Detection
- Internal Calibrated RC Oscillator
- External and Internal Interrupt Sources
- Six Sleep Modes: Idle, ADC Noise Reduction, Power-save, Power-Down, Standby, and Extended Standby

I/O and Packages

- 32 Programmable I/O Lines
- 40-pin PDIP, 44-lead TQFP, and 44-pad MLF

Operating Voltages

- 4.5-5.5V for ATmega16

Speed Grades

- 0-16 MHz for ATmega16

Power Consumption at 4 MHz, 3V, 35 °C

- Active: 1.1mA; Idle Mode: 0.35mA; Power-down Mode: < 1µA

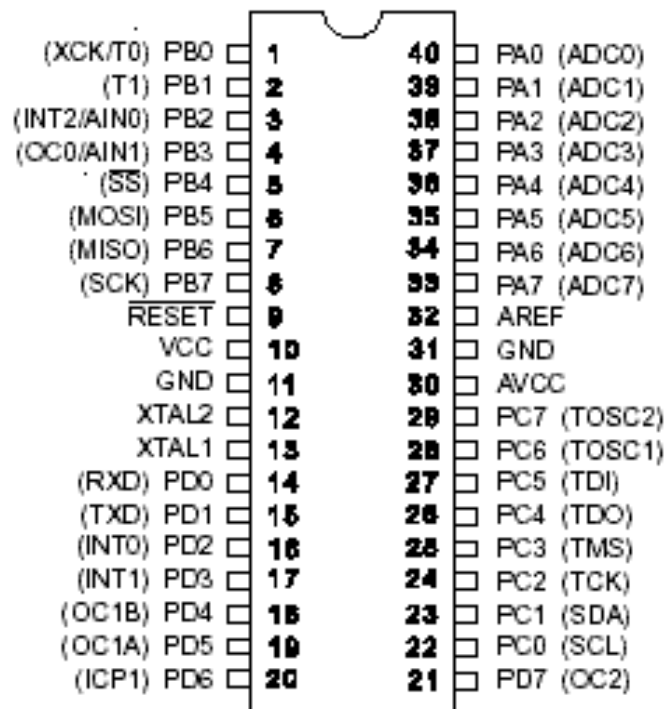

Figure 2 : ATmega16 Pin Description

Pin Description

- **VCC**
Digital supply voltage. (+5V)
- **GND:**
Ground. (0 V) Note there are 2 ground Pins.
- **Port A (PA7 - PA0)**
Port A serves as the analog inputs to the A/D Converter. Port A also serves as an 8-bit bi-directional I/O port, if the A/D Converter is not used. When pins PA0 to PA7 are used as inputs and are externally pulled low, they will source current if the internal pull-up resistors are activated. The Port A pins are tri-stated when a reset condition becomes active, even if the clock is not running.
- **Port B (PB7 - PB0)**
Port B is an 8-bit bi-directional I/O port with internal pull-up resistors (selected for each bit). Port B also serves the functions of various special features of the ATmega16 which are presently of no use in this project.
- **Port C (PC7 - PC0)**
Port C is an 8-bit bi-directional I/O port with internal pull-up resistors (selected for each bit). Port C also serves the functions of the JTAG interface and other special features of the ATmega16 which are currently not used in this project.
- **Port D (PD7 - PD0)**
Port D is an 8-bit bi-directional I/O port with internal pull-up resistors (selected for each bit). Port D also serves the functions of various special features of the ATmega16 as listed on page 63 of datasheet which are currently not being used in this project.

- **RESET**

Reset Input. A low level on this pin for longer than the minimum pulse length will generate a reset, even if the clock is not running.

- **XTAL1**

External oscillator pin 1

- **XTAL2**

External oscillator pin 2

- **AVCC**

AVCC is the supply voltage pin for PortA and the A/D Converter. It should be externally connected to VCC, even if the ADC is not used. If the ADC is used, it should be connected to VCC through a low-pass filter.

- **AREF**

AREF is the analog reference pin for the A/D Converter.

- **I/O Ports**

Input Output functions are set by three Registers for each PORT.

DDRX ----> Sets whether a pin is Input or Output of PORTX.

PORTX ---> Sets the Output Value of PORTX.

PINX -----> Reads the Value of PORTX.

- **REGISTERS**

All the configurations in microcontroller is set through 8 bit (1 byte) locations in RAM (RAM is a bank of memory bytes) of the microcontroller called as Registers. All the functions are mapped to its locations in RAM and the value we set at that location that is at that Register configures the functioning of microcontroller. There are total 32 x 8bit registers in Atmega-16. As Register size of this microcontroller is 8 bit, it called as 8 bit microcontroller.

2.1.3 Motor Driver - L293D

The L293D is a 16 pin motor driver IC. The L293 and L293D are quadruple high-current half-H drivers. The L293 is designed to provide bidirectional drive currents of up to 1 A at voltages from 4.5 V to 36 V. The L293D is designed to provide bidirectional drive currents of up to 600-mA at voltages from 4.5 V to 36 V. Both devices are designed to drive inductive loads such as relays, solenoids, dc and bipolar stepping motors, as well as other high-current/high-voltage loads in positive-supply applications.

All the inputs are TTL compatible. Each output is a complete totem-pole drive circuit, with a Darlington transistor sink and a pseudo-Darlington source. Drivers are enabled in pairs, with drivers 1 and 2 enabled by 1,2EN and drivers 3 and 4 enabled by 3,4EN. When an enable input is high, the associated drivers are enabled and their outputs are active and in phase with their inputs. When the enable input is low, those drivers are disabled and their outputs are off and in the high-impedance state.

With the proper data inputs, each pair of drivers forms a full-H (or bridge) reversible drive suitable for solenoid or motor applications. On the L293, external high-speed output clamp diodes should be used for inductive transient suppression. A VCC1 terminal, separate from VCC2, is provided for the logic inputs to minimize device power dissipation. The L293 and L293D are characterized for operation from 0°C to 70°C.

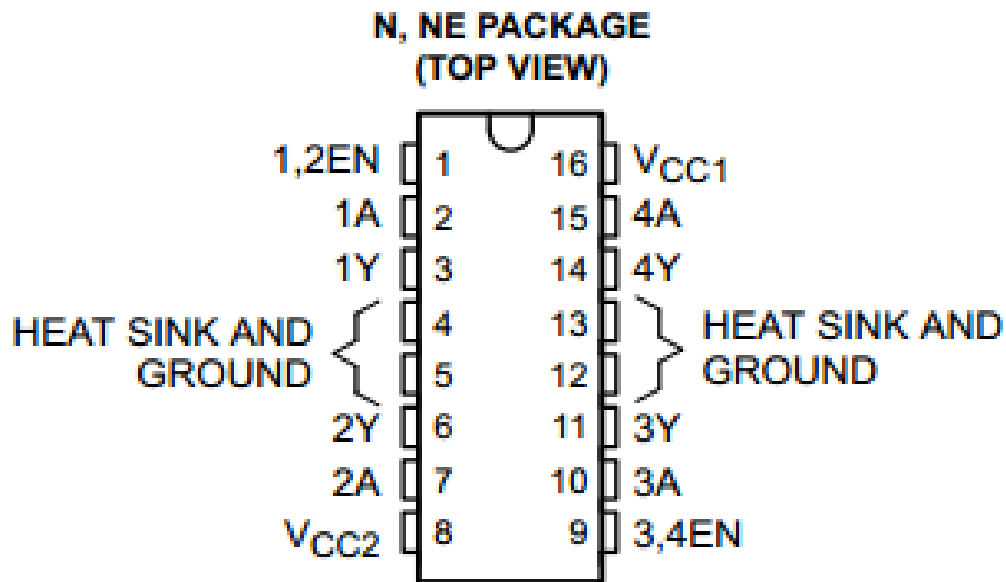

Figure 3 : L293D Pin Description

Table 3 : L293D Pin Functions

Pin No	Function	Name
1	Enable pin for Motor 1; active high	Enable 1,2
2	Input 1 for Motor 1	Input 1
3	Output 1 for Motor 1	Output 1
4	Ground (0V)	Ground
5	Ground (0V)	Ground
6	Output 2 for Motor 1	Output 2
7	Input 2 for Motor 1	Input 2
8	Supply voltage for Motors; 9-12V (up to 36V)	Vcc 2
9	Enable pin for Motor 2; active high	Enable 3,4
10	Input 1 for Motor 2	Input 3
11	Output 1 for Motor 2	Output 3
12	Ground (0V)	Ground
13	Ground (0V)	Ground
14	Output 2 for Motor 2	Output 4
15	Input 2 for Motor 2	Input 4
16	Supply voltage; 5V (up to 36V)	Vcc 1

2.1.4 Power Supply

Power supply is a reference to a source of electrical power. A device or system that supplies electrical or other types of energy to an output load or group of loads is called a power supply unit or PSU. The term is most commonly applied to electrical energy supplies, less often to mechanical ones, and rarely to others. Here in our application we need a 5v DC power supply for all electronics involved in the project. This requires step down transformer, rectifier, voltage regulator and filter circuit for generation of 5v DC power. Here a brief description of all the components are given as follows:

Transformer

Transformer is a device that transfers electrical energy from one circuit to another through inductively coupled conductors— the transformer's coils or "windings". A varying current in the first or "primary" winding creates a varying magnetic field in the core (or cores) of the transformer. This varying magnetic field induces a varying electromotive force (EMF) or "voltage" in the "secondary" winding. This effect is called mutual induction.



Figure 4 : Transformer

If a load is connected to the secondary circuit, electric charge will flow in the secondary winding of the transformer and transfer energy from the primary circuit to the load connected in the secondary circuit. The secondary induced voltage V_s , of an

ideal transformer, is scaled from the primary V_p by a factor equal to the ratio of the number of turns of wire in the respective windings:

$$\frac{V_S}{V_P} = \frac{N_S}{N_P}$$

By appropriate selection of the number of turns, a transformer thus allows an alternating voltage to be stepped up - by making N_s more than N_p or stepped down, by making N_s less than N_p .

Bridge Rectifier

A bridge rectifier makes use of four diodes in a bridge arrangement to achieve full - wave rectification. This is a widely used configuration, both with individual diodes wired as shown and with single component bridges where the diode bridge is wired internally.

Basic Operation

In the diagrams below, when the input connected to the left corner of the diamond is positive, and the input connected to the right corner is negative, current flows from the upper supply terminal to the right along the red (positive) path to the output, and returns to the lower supply terminal via the blue (negative) path.

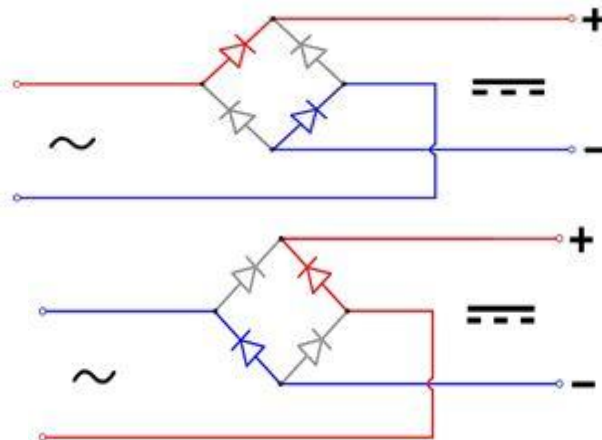

Figure 5 : Rectification Operation

When the input connected to the left corner is negative, and the input connected to the right corner is positive, current flows from the lower supply terminal to the right along the path to the output, and returns to the upper supply terminal via the blue path.

In each case, the upper right output remains positive and lower right output negative. Since this is true whether the input is AC or DC, this circuit not only produces a DC output from an AC input, it can also provide what is sometimes called "reverse polarity protection". That is, it permits normal functioning of DC - powered equipment when batteries have been installed backwards, or when the leads (wires) from a DC power source have been reversed, and protects the equipment from potential damage caused by reverse polarity.

Output Smoothing

For many applications, especially with single phase AC where the full - wave bridge serves to convert an AC input into a DC output, the addition of a capacitor may be desired because the bridge alone supplies an output of fixed polarity but continuously varying or "pulsating" magnitude. The function of this capacitor, known as a reservoir capacitor (or smoothing capacitor) is to lessen the variation in (or 'smooth') the rectified AC output voltage waveform from the bridge.

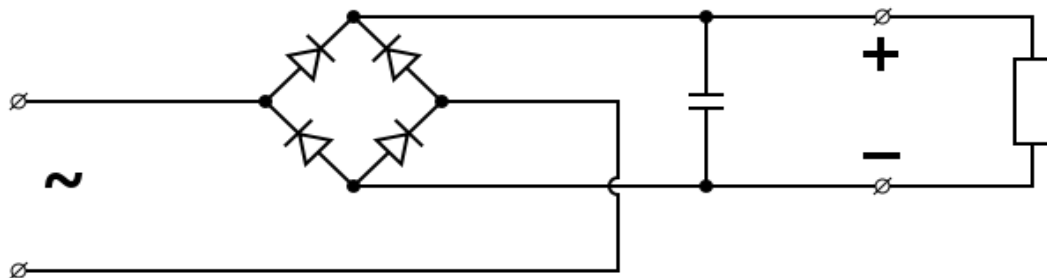

Figure 6 : Output Smoothing of Rectifier

One explanation of smoothing is that the capacitor provides a low impedance path to the AC component of the output, reducing the AC voltage across, and AC current through, the resistive load. In less technical terms, any drop in the output voltage and current of the bridge tends to be canceled by loss of charge in the capacitor. This charge flows out as additional current through the load. Thus the change of load current and voltage is reduced relative to what would occur without the capacitor. Increases of voltage correspondingly store excess charge in the capacitor, thus moderating the change in output voltage / current.

Regulator IC (78xx)

It is a three pin IC used as a voltage regulator. It converts unregulated DC current into regulated DC current. Normally we get fixed output by connecting the voltage regulator at the output of the filtered DC. It can also be used in circuits to get a low DC voltage from a high DC voltage (for example we use 7805 to get 5V from 12V). It is a fixed (78xx,79xx) and positive voltage regulator. 7805 gives fixed 5V DC voltage if input voltage is in (7.5V, 20V).

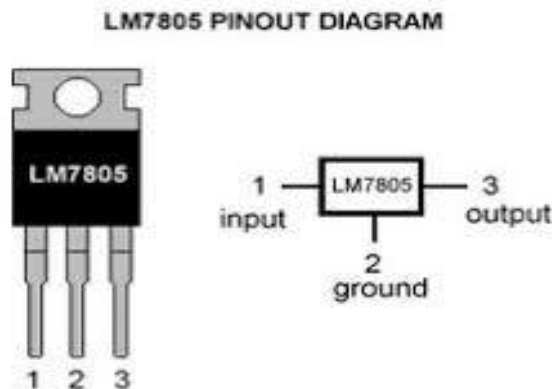

Figure 7 : Regulator

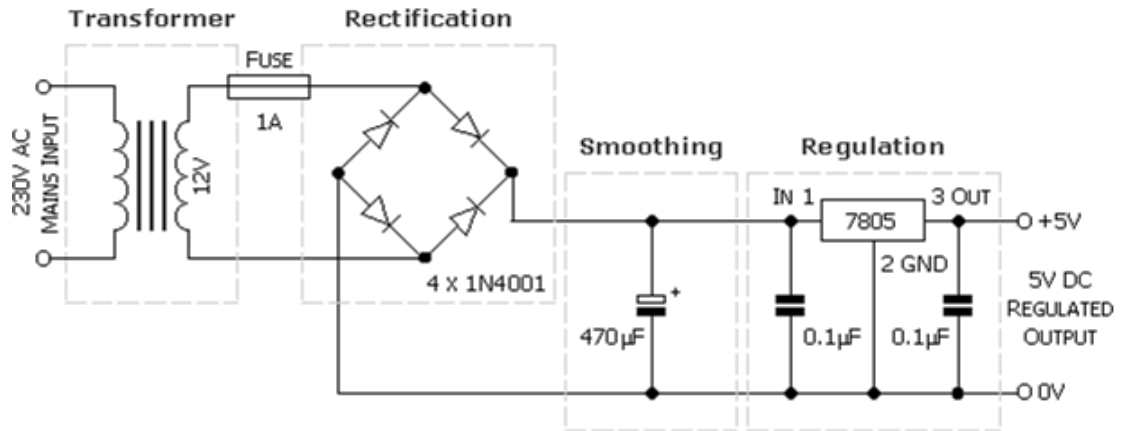

Figure 8 : Power Supply Circuit Diagram

2.1.5 Other Components

- **Capacitors**

Electrolytic Capacitors

An electrolytic capacitor is a capacitor that uses an electrolyte (an ionic conducting liquid) as one of its plates to achieve a larger capacitance per unit volume than other types, but with performance disadvantages. All capacitors conduct alternating current (AC) and block direct current (DC) and can be used, to couple circuit blocks allowing AC signals to be transferred while blocking DC power, to store energy, and to filter signals according to their frequency.

Ceramic Capacitors

A ceramic capacitor is a fixed value capacitor in which ceramic material acts as the dielectric. It is constructed of two or more alternating layers of ceramic and a metal layer acting as the electrodes. The composition of the ceramic material defines the electrical behavior and therefore applications.

- **Resistors**

A resistor is a passive two-terminal electrical component that implements electrical resistance as a circuit element. The current through a resistor is in direct proportion to the voltage across the resistor's terminals. This relationship is represented by Ohm's law:

$$I = \frac{V}{R}$$

where I is the current through the conductor in units of amperes, V is the potential difference measured across the conductor in units of volts, and R is the resistance of the conductor in units of ohms.

- **Crystal Oscillator**

A crystal oscillator is an electronic oscillator circuit that uses the mechanical resonance of a vibrating crystal of piezoelectric material to create an electrical signal with a very precise frequency. This frequency is commonly used to keep track of time, to provide a stable clock signal for digital integrated circuits, and to stabilize frequencies for radio transmitters and receivers. The most common type of piezoelectric resonator used is the quartz crystal, so oscillator circuits incorporating them became known as crystal oscillators, but other piezoelectric materials including polycrystalline ceramics are used in similar circuits.

- **Regulator**

A voltage regulator is designed to automatically maintain a constant voltage level. A voltage regulator may be a simple "feed-forward" design or may include negative feedback control loops. It may use an electromechanical mechanism, or electronic components. Depending on the design, it may be used to regulate one or more AC or DC voltages.

Electronic voltage regulators are found in devices such as computer power supplies where they stabilize the DC voltages used by the processor and other elements. In automobile alternators and central power station generator plants, voltage regulators control the output of the plant. In an electric power distribution system, voltage regulators may be installed at a substation or along distribution lines so that all customers receive steady voltage independent of how much power is drawn from the line.

- **Geared Motor**

"Gear motor" refers to a combination of a motor plus a reduction gear train. These are often conveniently packaged together in one unit. The gear reduction (gear train) reduces the speed of the motor, with a corresponding increase in torque. Gear ratios range from just a few (e.g. 3) to huge (e.g. 500). A small ratio can be accomplished with a single gear pair, while a large ratio requires a series of gear reduction steps and thus more gears. There are a lot of different kinds of gear reduction.

- **LED**

A light-emitting diode (LED) is a two-lead semiconductor light source. It is a pn-junction diode, which emits light when activated. When a suitable voltage is applied to the leads, electrons are able to recombine with electron holes within the device, releasing energy in the form of photons. This effect is called electroluminescence, and the color of the light (corresponding to the energy of the photon) is determined by the energy band gap of the semiconductor.

- **Battery 9V**

The nine-volt battery in its most common form was introduced for the early transistor radios. It has a rectangular prism shape with rounded edges and a polarized snap connector at the top. This type is commonly used in pocket radios, paintball guns, and small electronic devices. They are also used as backup power to keep the time in certain electronic clocks. This format is commonly available in primary carbon-zinc and alkaline chemistry, in primary lithium iron disulfide, and in rechargeable form in nickel-cadmium, nickel-metal hydride and lithium-ion. Mercury oxide batteries in this form have not been manufactured in many years due to their mercury content.

- **Headphone Jack**

A small round connector for accepting the pin-shaped plug from a standard pair of music headphones. Older phones used a smaller 2.5mm jack for phone headsets. Either size can support stereo sound and/or a microphone, depending on the number of separate connector rings on the plug or jack. 3.5mm refers to the approximate diameter of the connector. 2.5 and 3.5 mm connectors look very similar, differing only in size.

2.2 Block Diagram

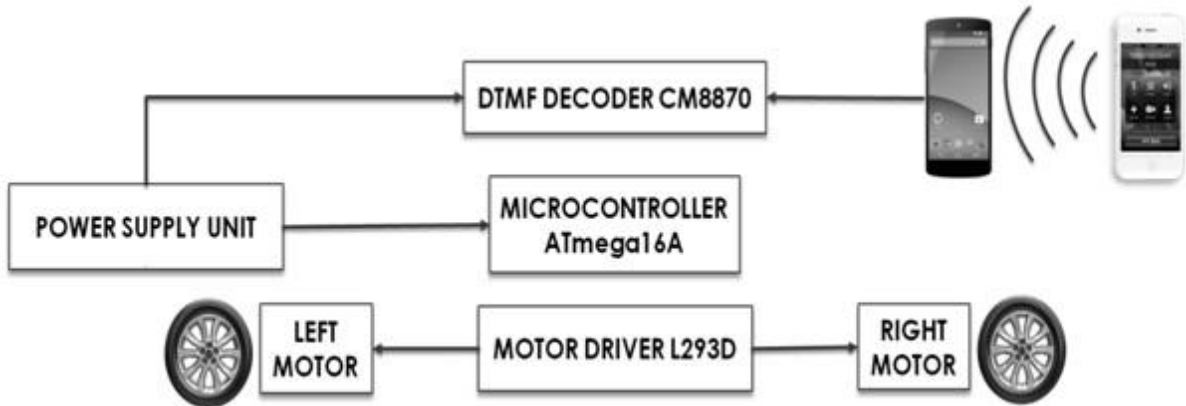

Figure 9 : Robot Block Diagram

2.3 Circuit Diagram

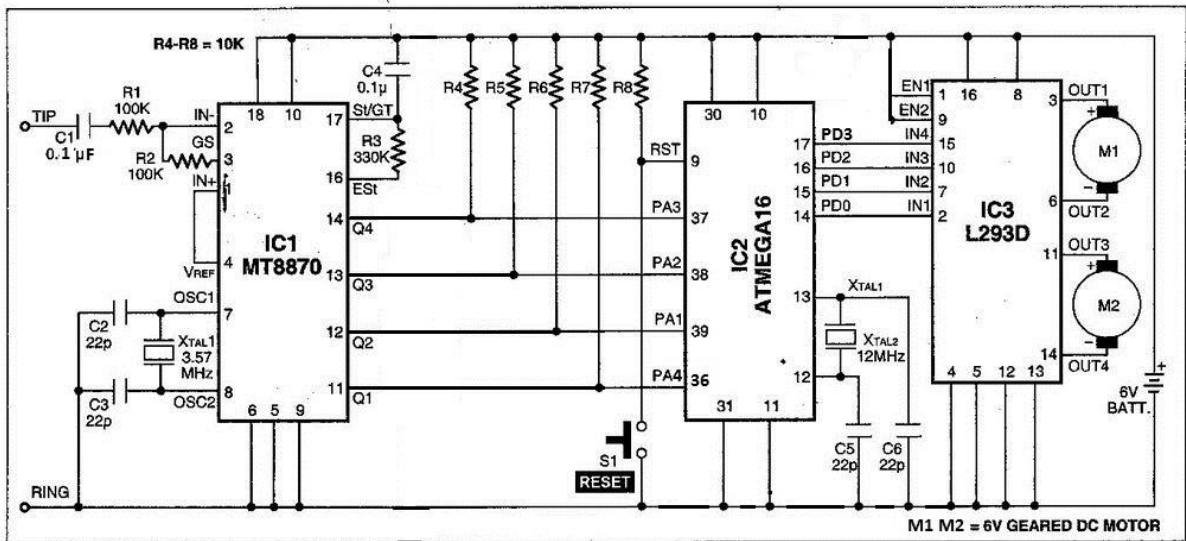

Figure 10 : Robot Circuit Diagram

CHAPTER 3

Software and Coding

3.1 Atmel Studio

Atmel Studio 6 is the integrated development platform (IDP) for developing and debugging Atmel ARM Cortex-M and Atmel AVR microcontroller (MCU) based applications. The Atmel Studio 6 IDP gives you a seamless and easy-to-use environment to write, build and debug your applications written in C/C++ or assembly code.

Atmel Studio 6 is free of charge and is integrated with the Atmel Software Framework (ASF) - a large library of free source code with 1,600 ARM and AVR project examples. ASF strengthens the IDP by providing, in the same environment, access to ready-to-use code that minimizes much of the low-level design required for projects. Use the IDP for our wide variety of AVR and ARM Cortex-M processor-based MCUs, including our broadened portfolio of Atmel SAM3 ARM Cortex-M3 and M4 Flash devices.



Figure 11 : Atmel Studio

Creating Atmel Studio Project

1. Creating a new project.

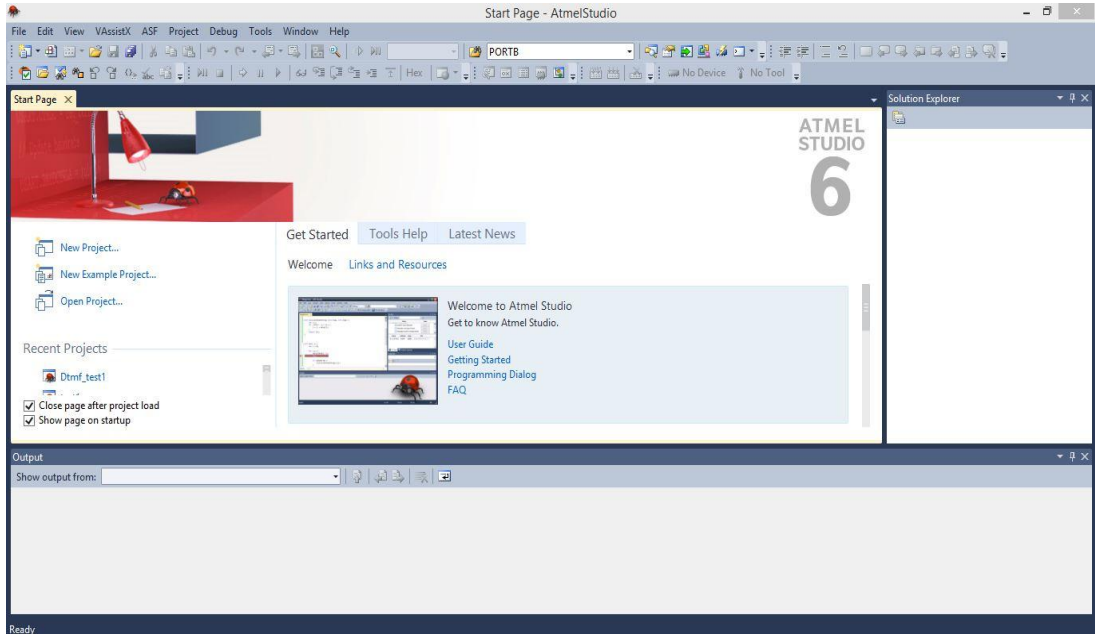

2. Choose GCC C Executable Project.

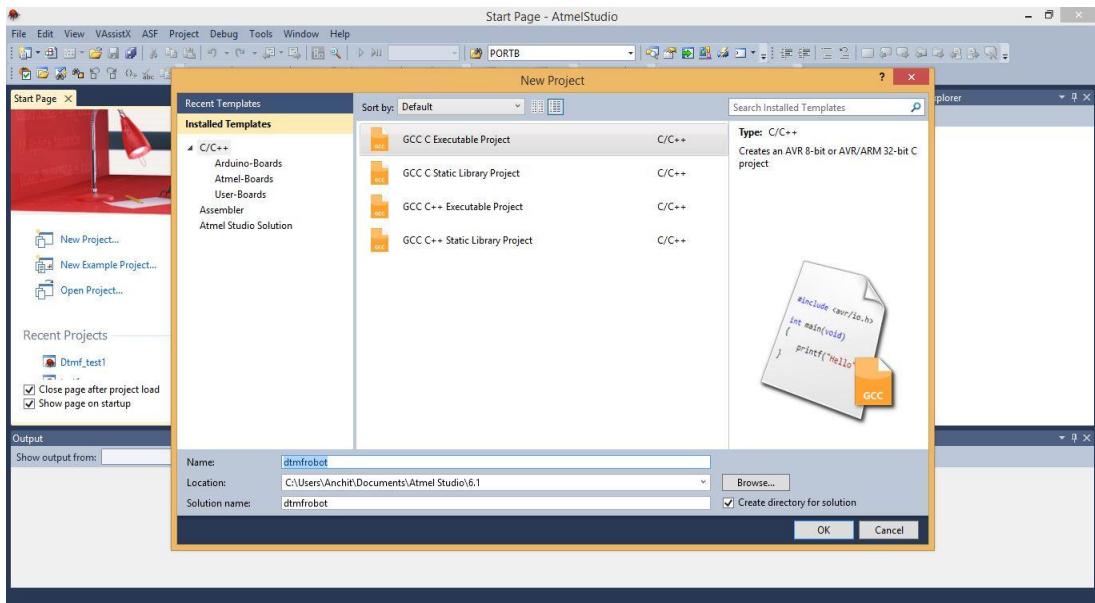

3. Choosing ATmega16 from the device selection dialog box.

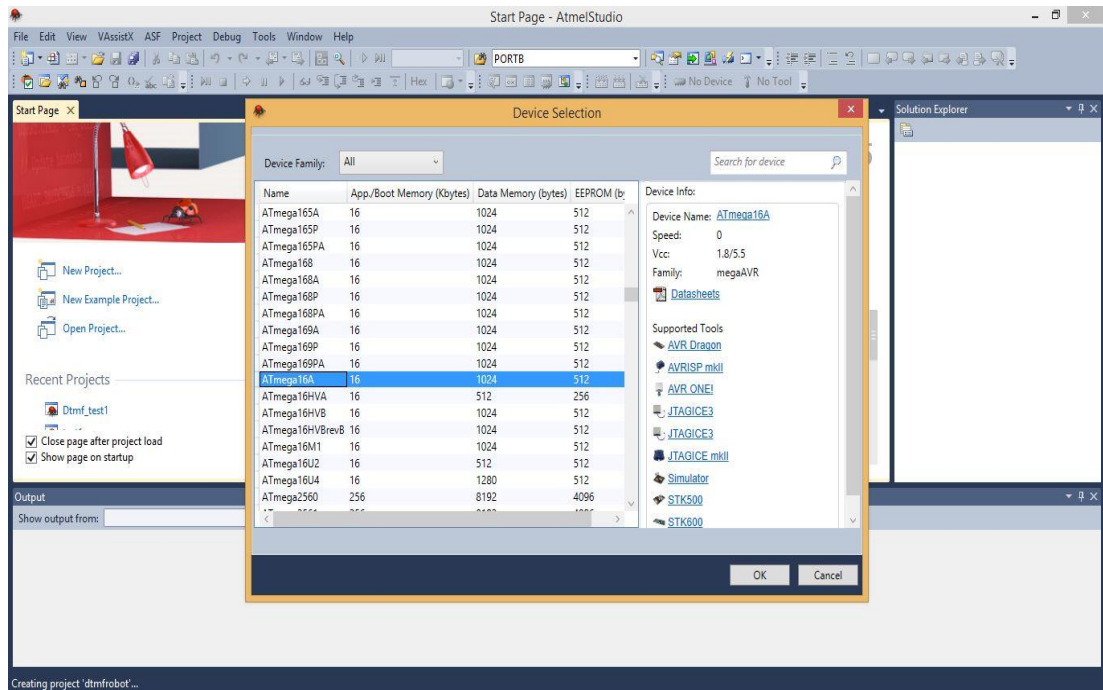

4. Writing the code

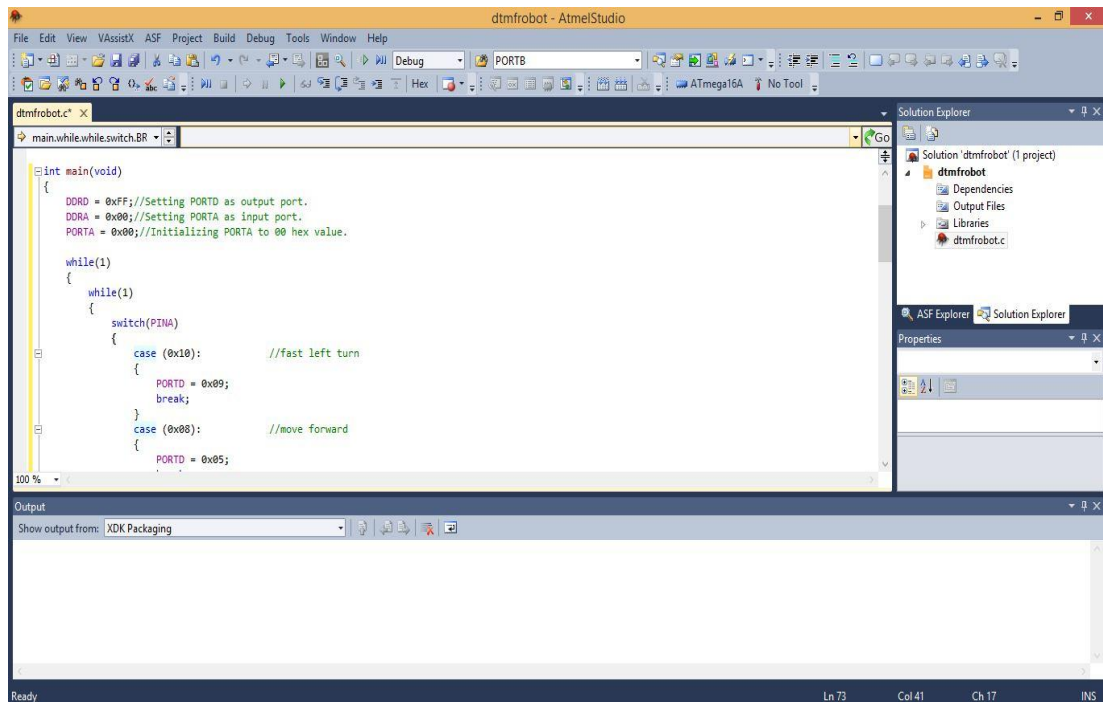

5. Compiling and building the code

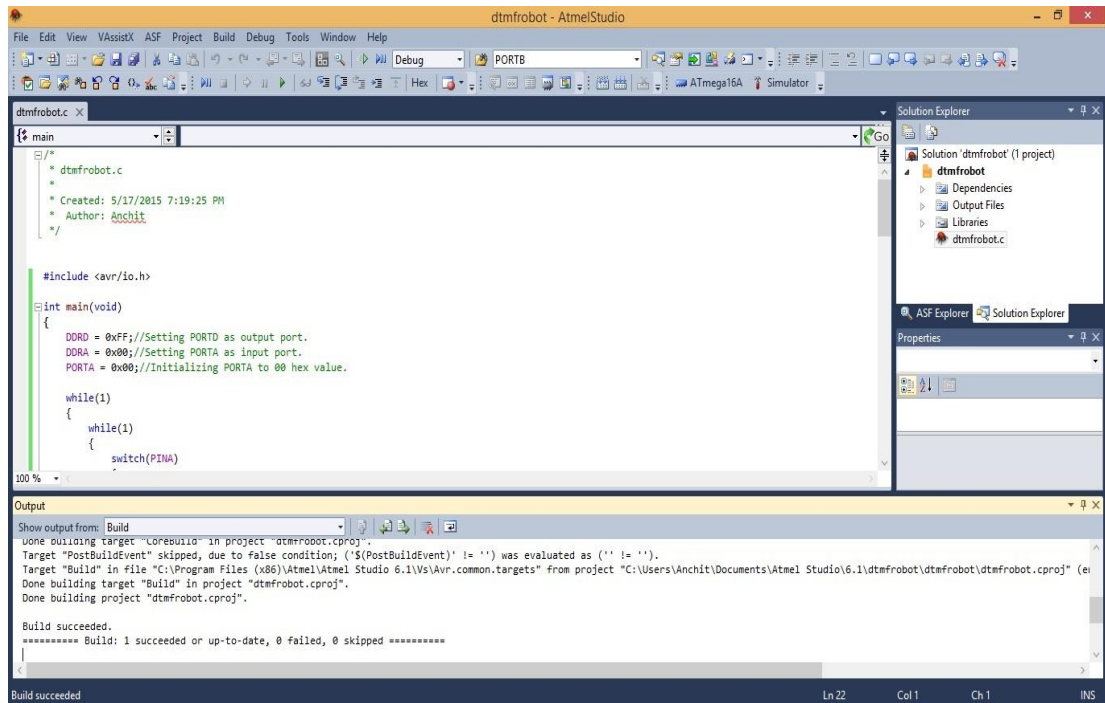

6. Generating .hex file.

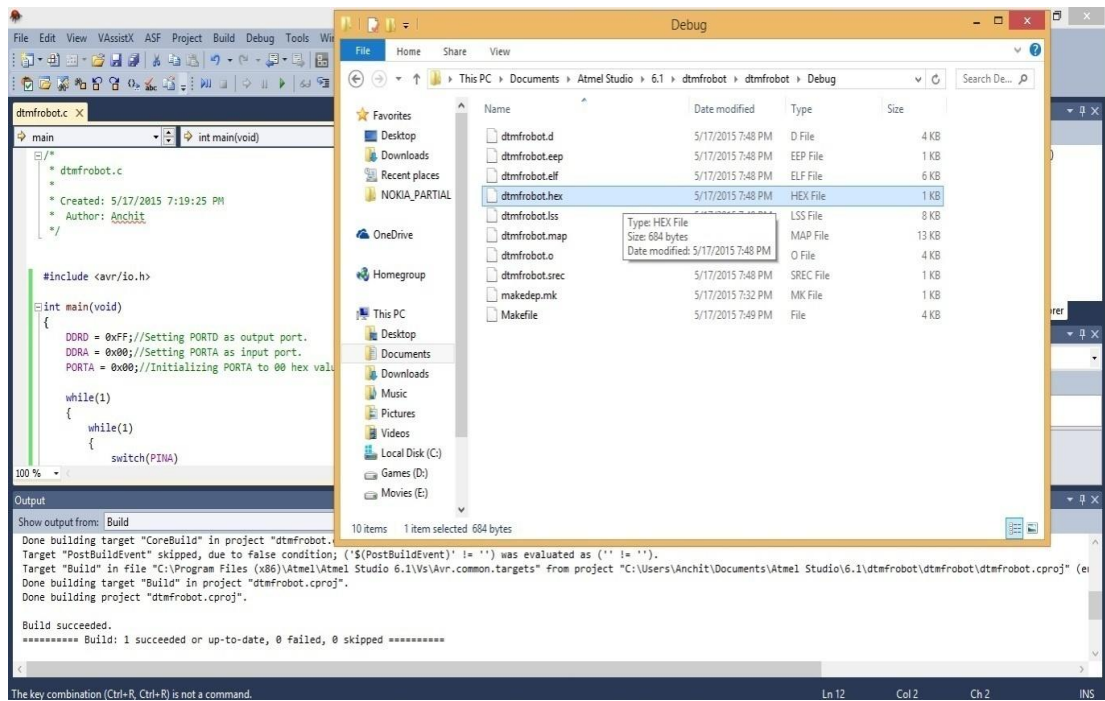

3.2 AVRDUDE

AVRDUDE is an utility to download/upload/manipulate the ROM and EEPROM contents of AVR microcontrollers using the in-system programming technique (ISP).

1. Open command word.

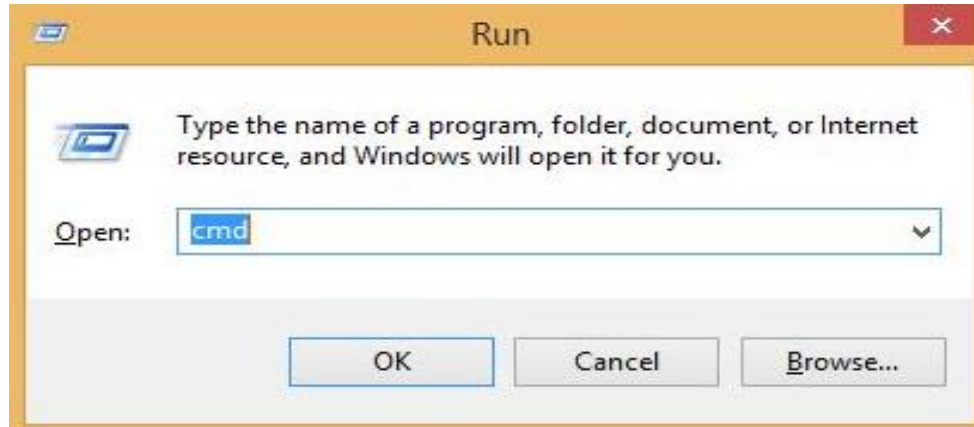

2. Write avrdude in the terminal to get all the available options.

```
C:\Windows\system32\cmd.exe
Microsoft Windows [Version 6.3.9600]
(c) 2013 Microsoft Corporation. All rights reserved.

C:\Users\Anchit>avrdude
Usage: avrdude [options]
Options:
  -p <partno>           Required. Specify AVR device.
  -b <baudrate>         Override RS-232 baud rate.
  -B <bitclock>         Specify JTAG/SPI/500v2 bit clock period <us>.
  -C <config-file>     Specify location of configuration file.
  -c <programmer>      Specify programmer type.
  -D                   Disable auto erase for flash memory
  -i <delay>           ISP Clock Delay [in microseconds]
  -P <port>            Specify connection port.
  -F                   Override invalid signature check.
  -e                   Perform a chip erase.
  -O                   Perform RC oscillator calibration (see AVR053).
  -U <memtype>:r|w|v:<filename>[:format]
                       Memory operation specification.
                       Multiple -U options are allowed, each request
                       is performed in the order specified.
  -n                   Do not write anything to the device.
  -U                   Do not verify.
  -u                   Disable safemode, default when running from a scrip
t.
  -s                   Silent safemode operation, will not ask you if
                       fuses should be changed back.
  -t                   Enter terminal mode.
  -E <exitspec>[L,<exitspec>] List programmer exit specifications.
  -x <extended_param>  Pass <extended_param> to programmer.
  -y                   Count # erase cycles in EEPROM.
  -Y <number>          Initialize erase cycle # in EEPROM.
  -v                   Verbose output. -v -v for more.
  -q                   Quell progress output. -q -q for less.
  -?                   Display this usage.

avrdude version 5.10, URL: <http://savannah.nongnu.org/projects/avrdude/>
C:\Users\Anchit>
```

Figure 12 : AVRDUDE

3. Write `avrdude -c avrisp` to get the list of programmers and select USBtiny

```
avr911 = Atmel AppNote AVR911 AVROSP [C:\WinAVR-20100110\bin\avrdude.conf:441]
avr109 = Atmel AppNote AVR109 Boot Loader [C:\WinAVR-20100110\bin\avrdude.conf:435]
butterfly = Atmel Butterfly Development Board [C:\WinAVR-20100110\bin\avrdude.conf:429]
usbtiny = USBtiny simple USB programmer, http://www.ladyada.net/make/usbtinyisp/ [C:\WinAVR-20100110\bin\avrdude.conf:423]
usbasp = USBasp, http://www.fischl.de/usbasp/ [C:\WinAVR-20100110\bin\avrdude.conf:417]
avr910 = Atmel Low Cost Serial Programmer [C:\WinAVR-20100110\bin\avrdude.conf:411]
```

4. Write `avrdude -c asdf` to get the list of microcontrollers and select m16 for ATmega16

```
m1284p = ATMEGA1284P [C:\WinAVR-20100110\bin\avrdude.conf:4446]
m644p = ATMEGA644P [C:\WinAVR-20100110\bin\avrdude.conf:4254]
m644 = ATMEGA644 [C:\WinAVR-20100110\bin\avrdude.conf:4064]
m324p = ATMEGA324P [C:\WinAVR-20100110\bin\avrdude.conf:3873]
m164p = ATMEGA164P [C:\WinAVR-20100110\bin\avrdude.conf:3692]
m16 = ATMEGA16 [C:\WinAVR-20100110\bin\avrdude.conf:3504]
c32 = AT90CAN32 [C:\WinAVR-20100110\bin\avrdude.conf:3313]
c64 = AT90CAN64 [C:\WinAVR-20100110\bin\avrdude.conf:3123]
c128 = AT90CAN128 [C:\WinAVR-20100110\bin\avrdude.conf:2933]
m128 = ATMEGA128 [C:\WinAVR-20100110\bin\avrdude.conf:2755]
m64 = ATMEGA64 [C:\WinAVR-20100110\bin\avrdude.conf:2574]
```

5. Finally, write `avrdude -c usbtiny -p attiny2313 -U flash:w:test_leds.hex` to write the code in the ATmega16.

```
avrdude: 260 bytes of flash written
avrdude: verifying flash memory against test_leds.hex:
avrdude: load data flash data from input file test_leds.hex:
avrdude: input file test_leds.hex auto detected as Intel Hex
avrdude: input file test_leds.hex contains 260 bytes
avrdude: reading on-chip flash data:

Reading : ##### | 100% 0.50s

avrdude: verifying ...
avrdude: 260 bytes of flash verified

avrdude: safemode: Fuses OK

avrdude done. Thank you.

C:\>_
```

3.3 PCB Wizard

PCB Wizard is a powerful package for designing single-sided and double-sided printed circuit boards (PCBs). It provides a comprehensive range of tools covering all the traditional steps in PCB production, including schematic drawing, schematic capture, component placement, automatic routing, Bill of Materials reporting and file generation for manufacturing. In addition, PCB Wizard offers a wealth of clever new features that do away with the steep learning curve normally associated with PCB packages.

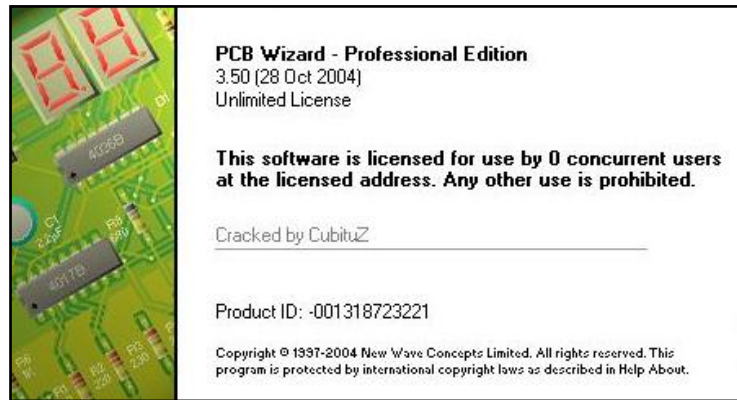
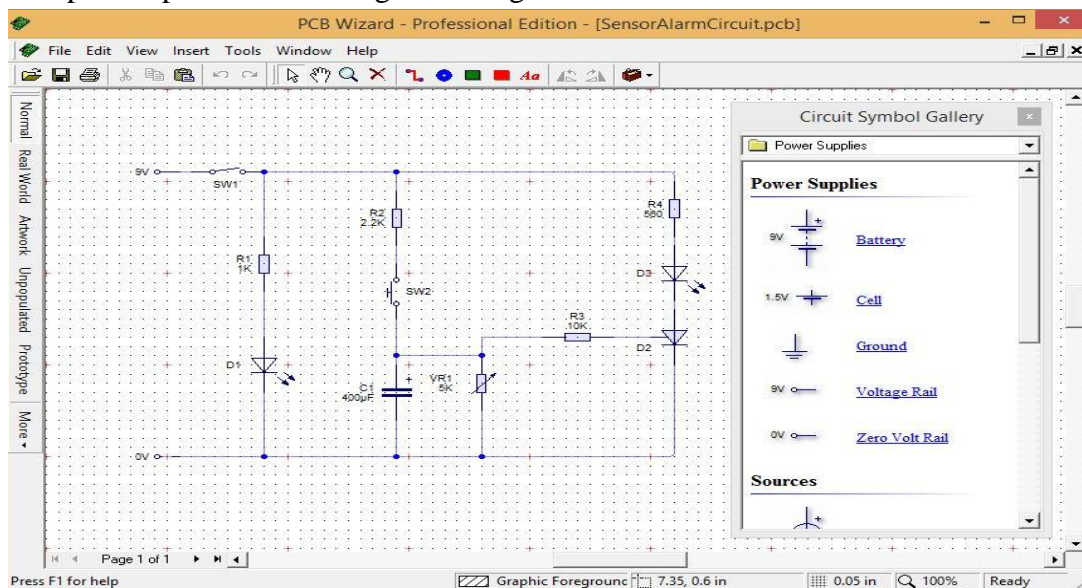

Figure 13 : PCB Wizard

Designing a circuit

1. Component placed and wiring according to the circuit.



2. Converting the circuit to schematic.

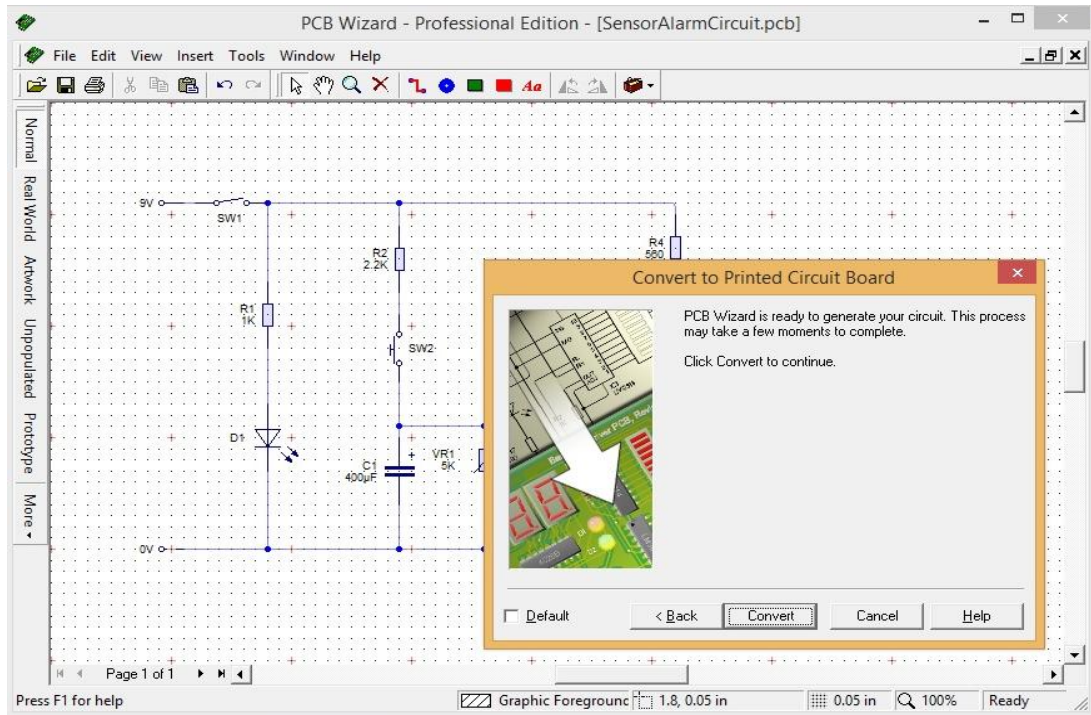

3. Components replaced to reduce complexity in schematic.

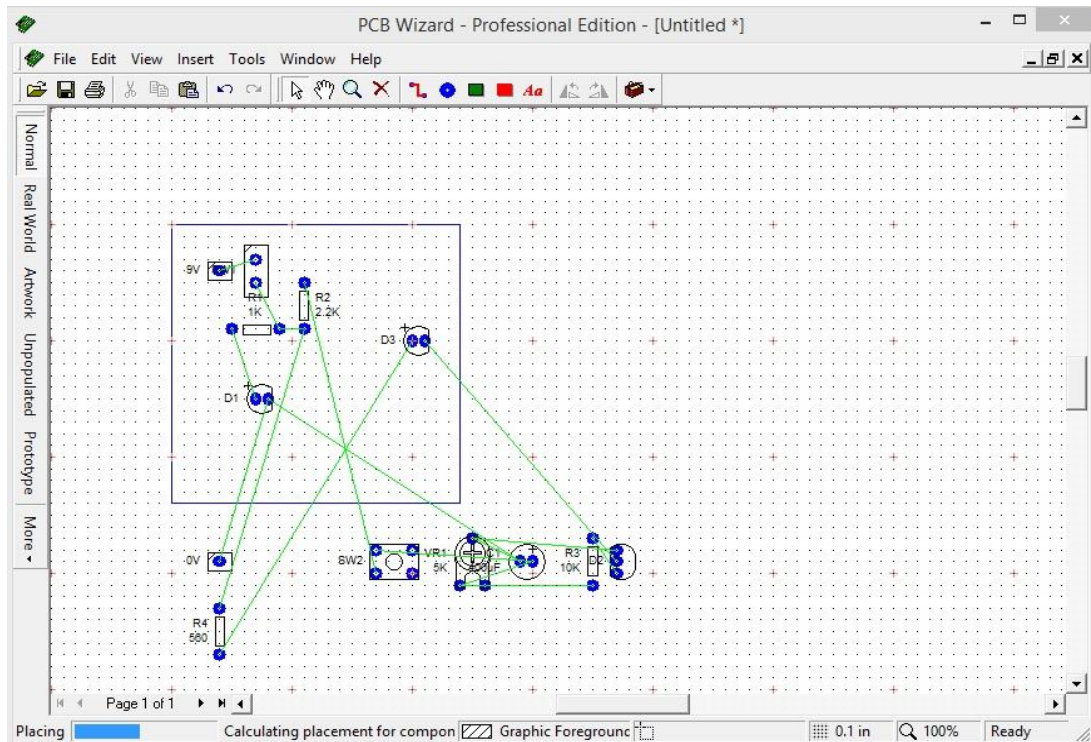

4. Real world PCB for the circuit.

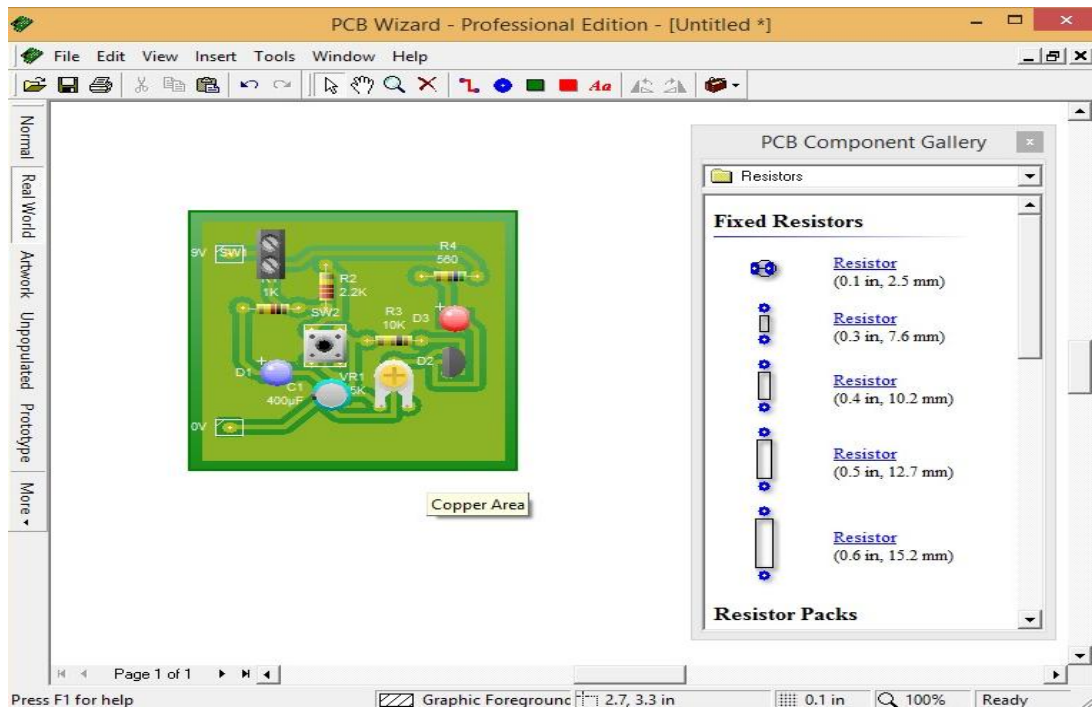

5. Art world PCB for the circuit.

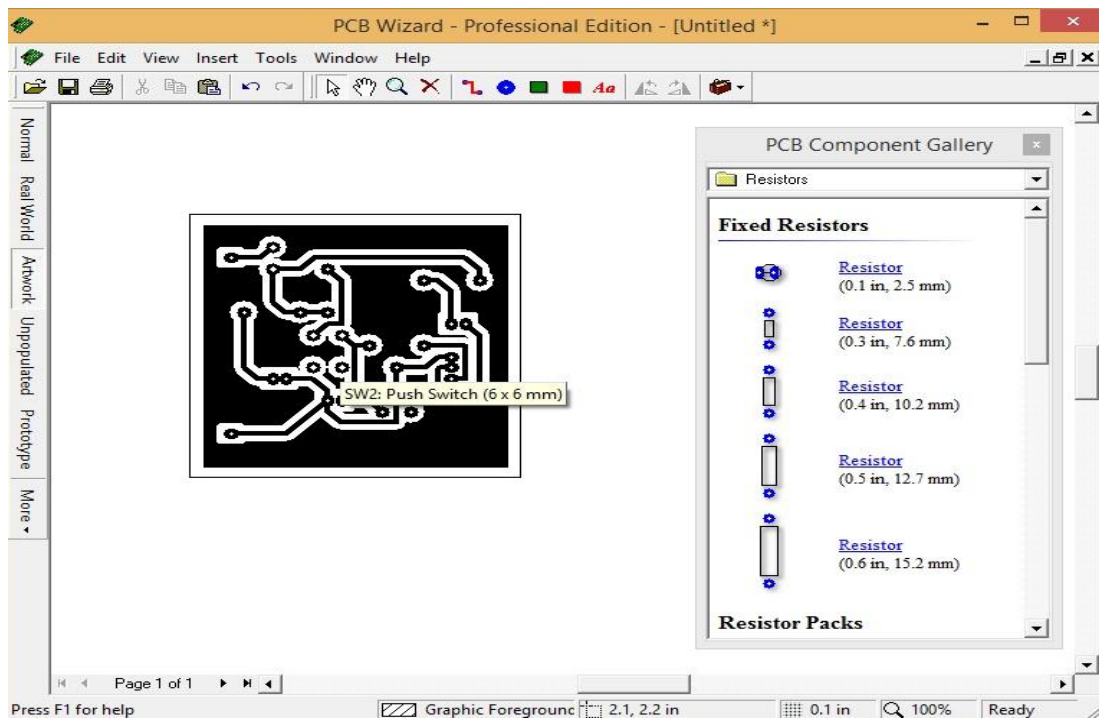

3.4 Programming

```
#include <avr/io.h>
int main(void)
{
    DDRD = 0xFF; // configuring the PORTD as Output port
    DDRA = 0x00; // configuring the PORTA as Input port
    PORTA = 0xFF; // Setting PortA to high

    while(1) // beginning the infinite loop
    {
        while(1) // beginning the 2nd infinite loop
        {
            switch(PINA)
            {
                case (0xFE): //turn fast left
                {
                    PORTD = 0x09;
                    break;
                }
                case (0xFD): //move forward
                {
                    PORTD = 0x05;
                    break;
                }
                case (0xFC): //turn fast right
                {
                    PORTD = 0x06;
                    break;
                }
                case (0xFB): //left turn
```

```

    {
        PORTD = 0x01;
        break;
    }
case (0xFA):           //stop
    {
        PORTD = 0x0C;
        break;
    }
case (0xF9):           //right turn
    {
        PORTD = 0x04;
        break;
    }
case (0xF8):           //reverse left turn
    {
        PORTD = 0x08;
        break;
    }
case (0xF7):           //reverse
    {
        PORTD = 0x0A;
        break;
    }
case (0xF6):           //reverse right turn
    {
        PORTD = 0x02;
        break;
    }
case (0xF5):           //stop
    {

```

```
        PORTD = 0x0C;
        break;
    }
    case (0xF4):           //stop
    {
        PORTD = 0x0C;
        break;
    }
    case (0xF3):           //stop
    {
        PORTD = 0x0C;
        break;
    }
}
}
}
```

CHAPTER 4

Methodology

3.1 Testing

Designing the DTMF Decoder, Microcontroller and Motor Driver circuits on the breadboard and testing them.

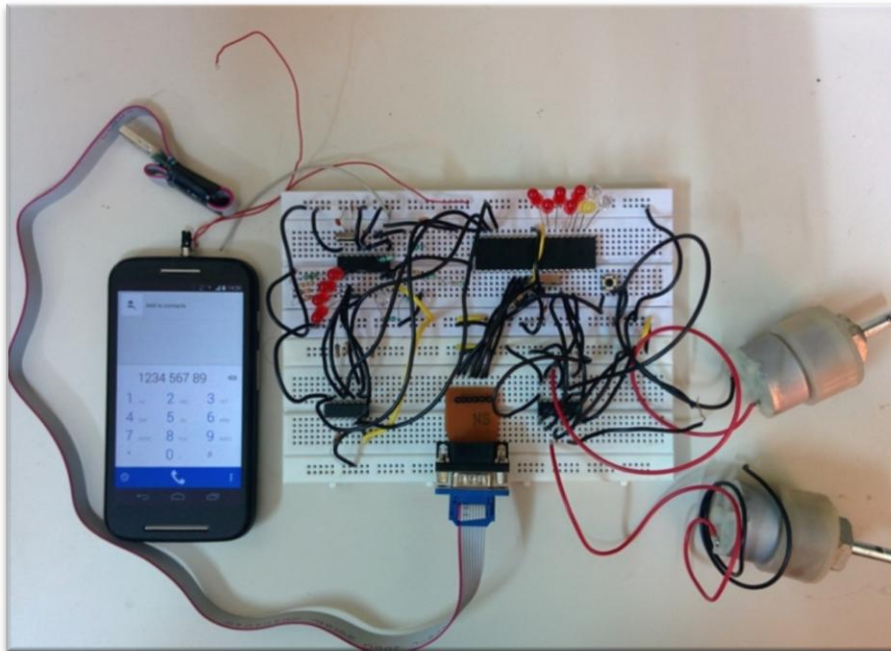
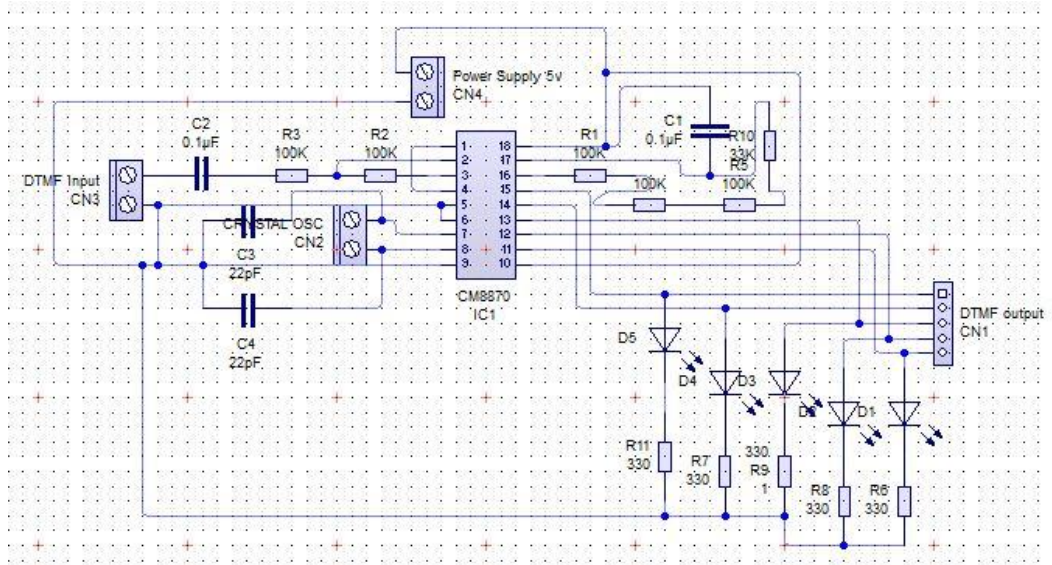

Figure 14 : Circuit Testing on Breadboard

3.2 Circuit Designing

Designing the DTMF Decoder, Microcontroller and Motor Driver PCBs using PCB Wizard.

DTMF Decoder Board



Schematic

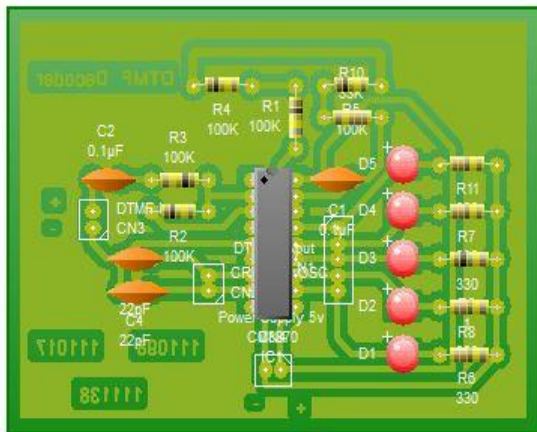

Real World

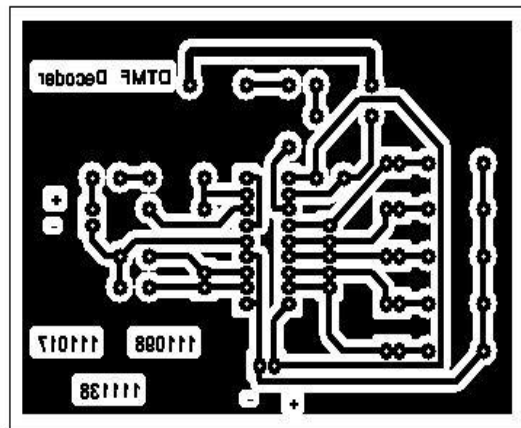

Art Work

Atmega16 Development Board

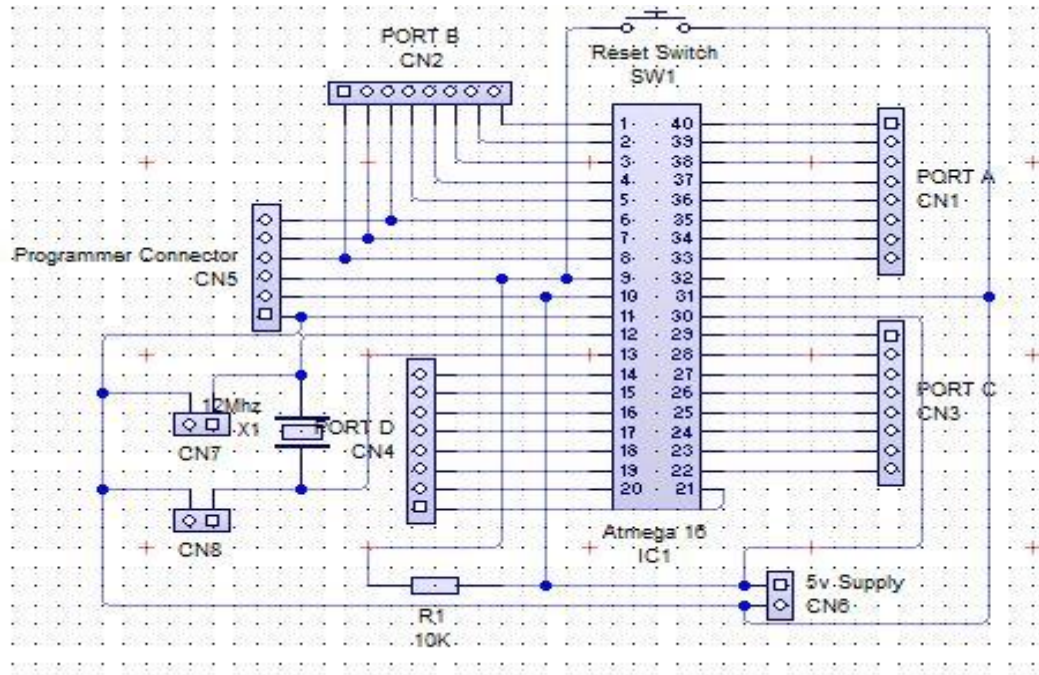

Schematic

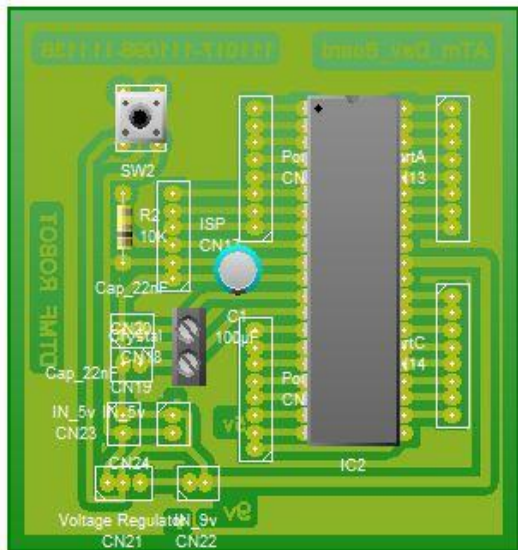

Real World

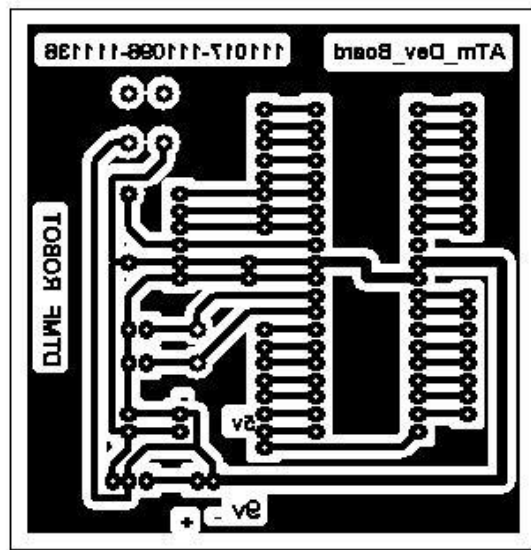

Art Work

Motor Driver Board

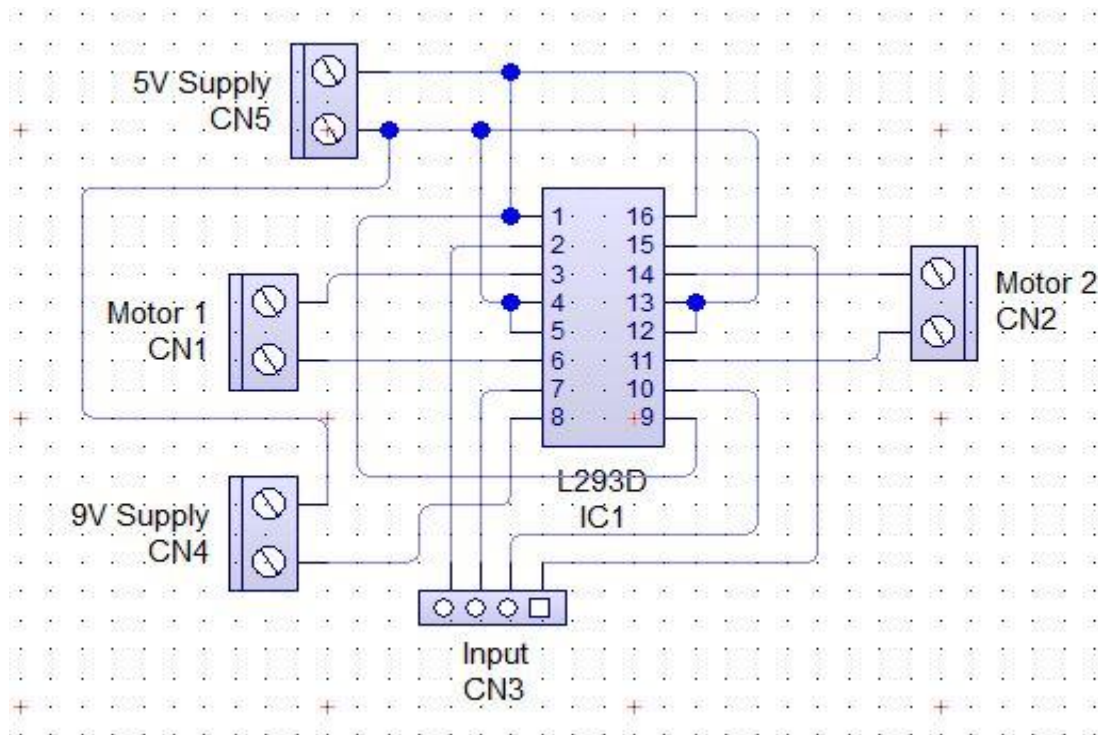

Schematic

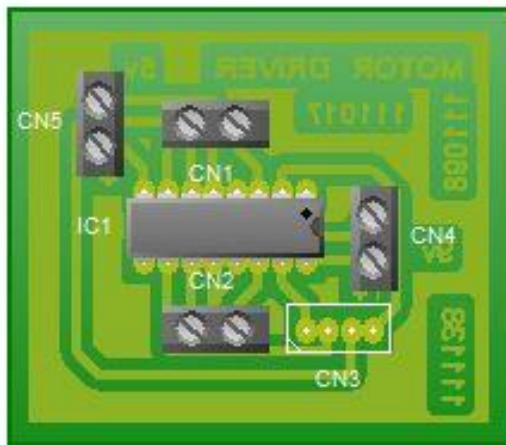

Real World

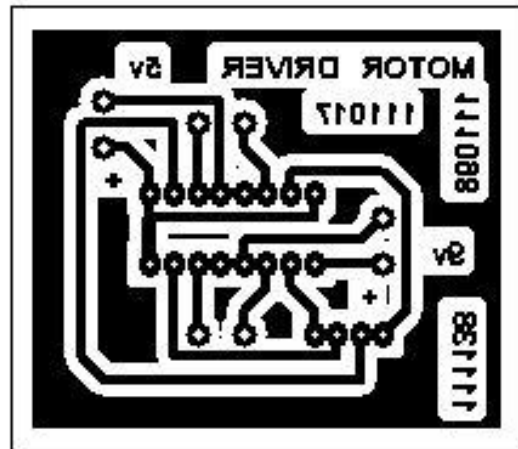

Art Work

3.3 Printing & Etching

Etching is where the excess copper is removed to leave the individual tracks or traces as they are sometimes called. Buckets, bubble tanks, and spray machines lots of different ways to etch, but most firms currently use high pressure conveyerised spray equipment. Spray etching is fast, ammoniacal etching solutions when sprayed can etch 55 microns of copper a minute. Less than 40 seconds to etch a standard 1 oz, 35 micron circuit board.

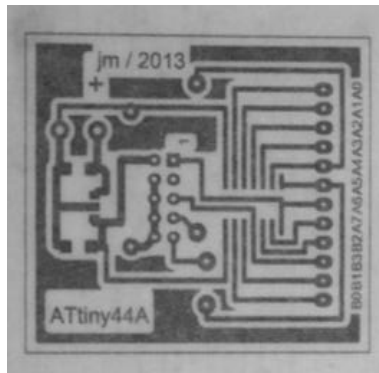
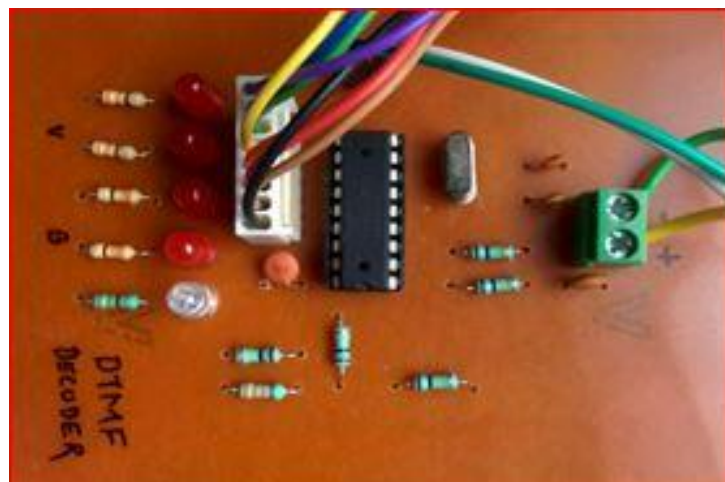
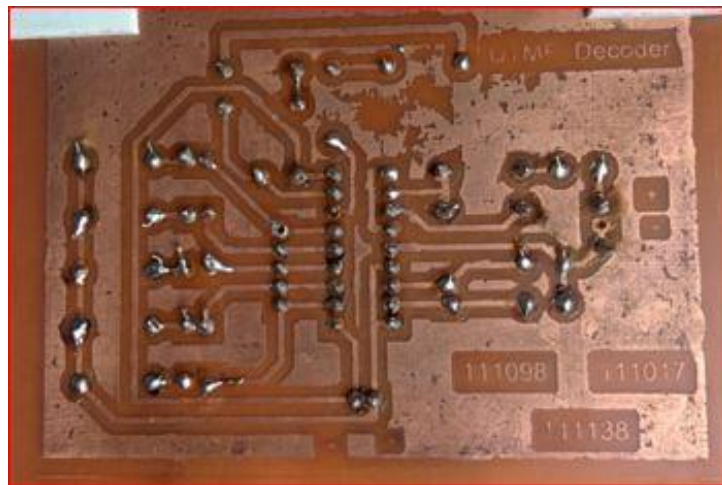

Figure 15 : PCB Etching

3.4 Soldering

Soldering is a process in which two or more metal items are joined together by melting and flowing a filler metal (solder) into the joint, the filler metal having a lower melting point than the adjoining metal. Soldering differs from welding in that soldering does not involve melting the work pieces. In brazing, the filler metal melts at a higher temperature, but the work piece metal does not melt. In the past, nearly all solders contained lead, but environmental concerns have increasingly dictated use of lead-free alloys for electronics and plumbing purposes.



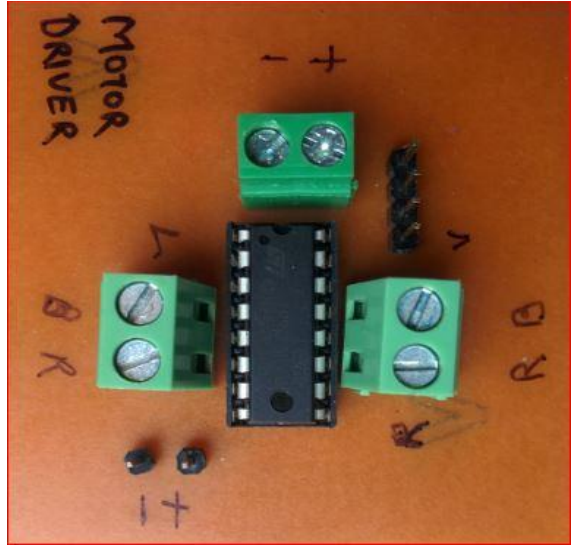
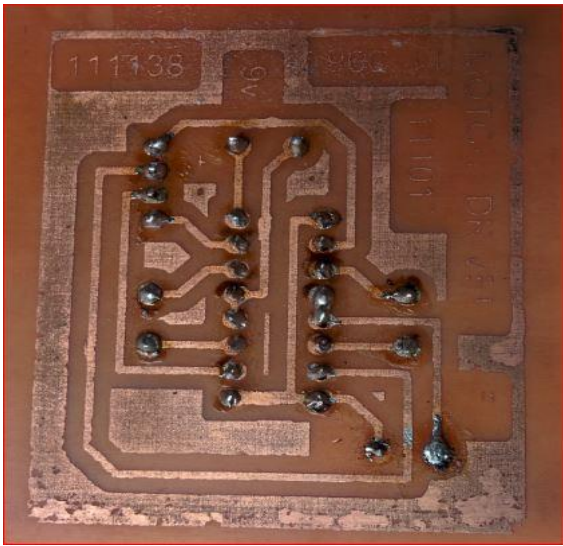
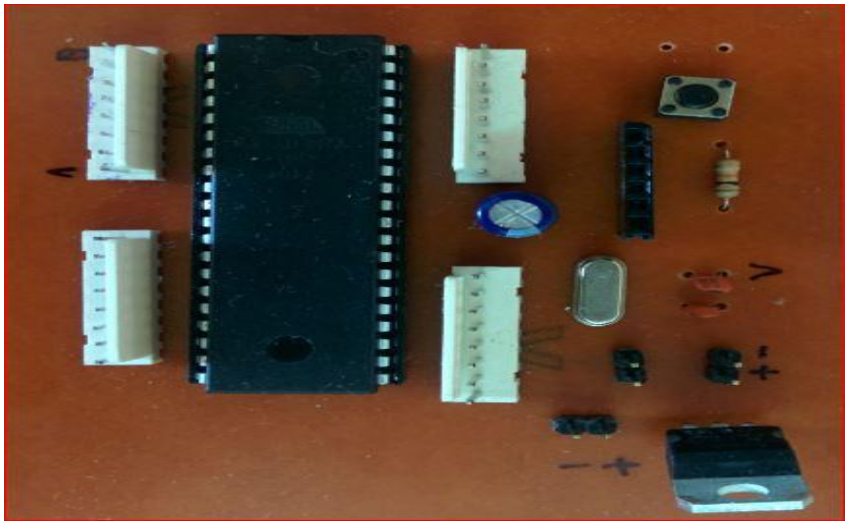
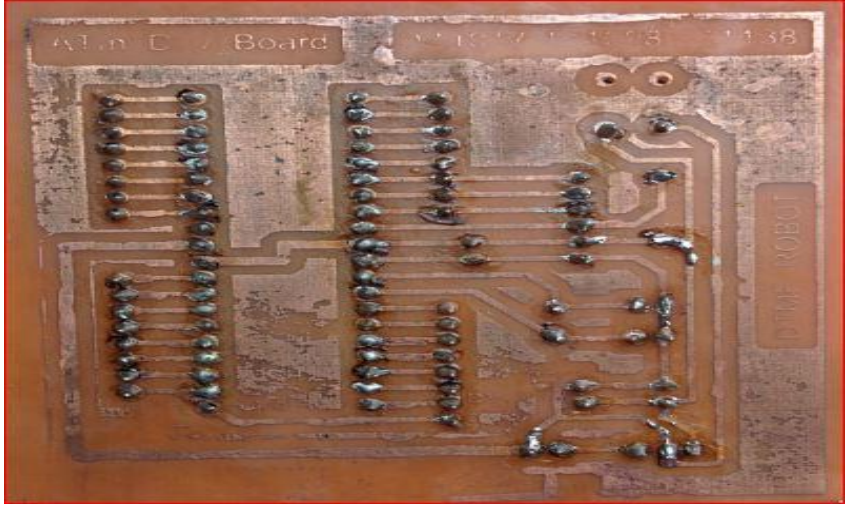

Figure 16 : PCB Soldering

3.5 Assembling

Connecting the DTMF Decoder, Microcontroller and Motor Driver PCBs and mounting them on the robot.

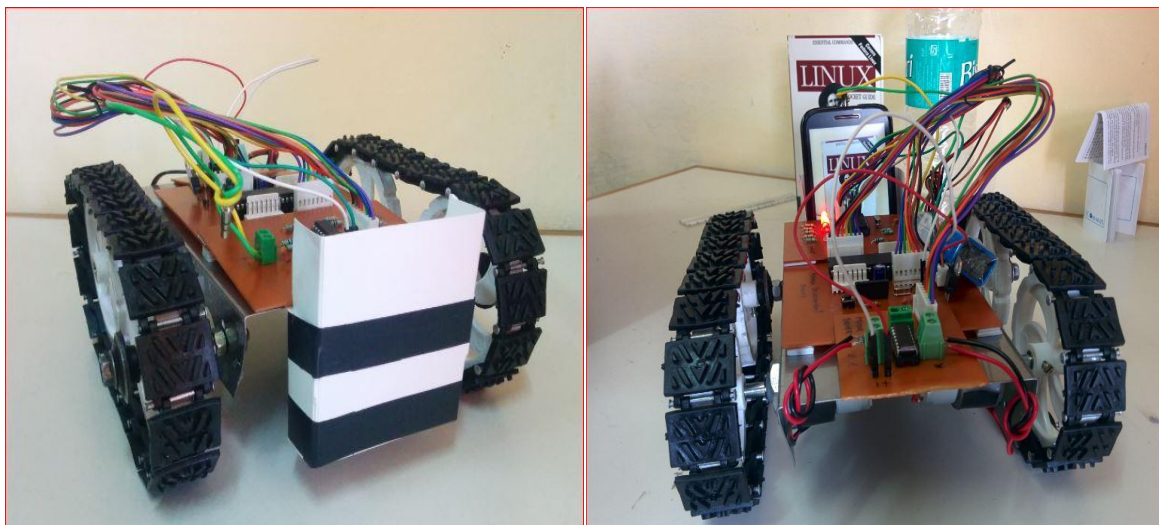
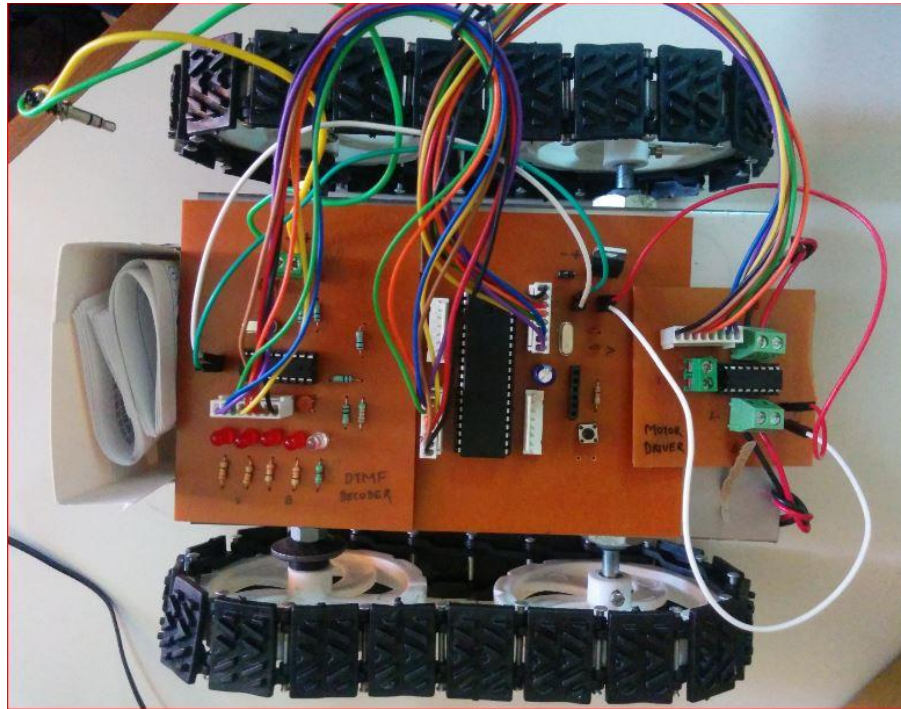

Figure 14 : PCBs Assembling

3.6 Working

DTMF decoder circuit

- DTMF keypads are employed in almost all landline and mobile handsets. Thus this technology is used in the telephone switching centers to identify the number dialed by the caller.
- The decoder distinguishes the DTMF tones and produces the binary sequence equivalent to key pressed in a DTMF (Dual Tone Multi Frequency) keypad.
- The circuit uses CM8870 DTMF decoder IC which decodes tone generated by the keypad of cell phone.
- DTMF signals can be tapped directly from the microphone pin of cell phone device. Cut the microphone wire and you will get two wires red and green. The red wire is the DTMF input to the circuit (TIP).
- The signals from the microphone wire are processed by the DTMF decoder IC which generates an equivalent binary sequence as a parallel output like Q1, Q2, Q3, and Q4.
- There is an inbuilt Op amp present inside the CM8870 decoder IC. The electrical signals from microphone pin are fed to inverting input of the Op Amp via a series of resistance ($100\text{k}\Omega$) and capacitance ($0.1\ \mu\text{F}$).
- The non-inverting input of Op-amp is connected to a reference voltage (pin4 - VREF). The voltage at VREF pin is $V_{cc}/2$.
- Pin 3 (GS) is the output of internal Op Amp, the feedback signal is given by connecting the output pin (pin3- GS) to inverting input pin (pin2- IN-) through a resistor ($270\text{k}\Omega$).

- The output of Op Amp is passed through a pre filter, low group and high group filters (filter networks). These filters contain switched capacitors to divide DTMF tones into low and high group signals (High group filters bypass the high frequencies whereas low group filter pass low frequencies).
- Next processing sections inside the IC are frequency detector and code detector circuits. Filtered frequency passed through these detectors.
- At last the four digit binary code is latched at the output of CM8870 DTMF decoder IC.

Microcontroller ATmega 16

- The output from DTMF decoder circuit is passed via the inverter and pull up resistors.
- This 4-bit binary code is fed to Microcontroller at PORTA which is configured as input.
- The program for Microcontroller is written in embedded c language using the Atmel Studio Software. AVRDUDE software is used to burn the hex file using the At Tiny programmer into the microcontroller.
- According to the program the output is drawn from the microcontroller to drive the motors.
- PORTD is set as output port, the output from this port is fed to the motor driver circuit which controls the motor and movement from the robot.

Motor Driver L293D

- There are 4 input pins for this L293D, pin 2,7 on the left and pin 15,10 on the right as shown on the pin diagram.
- Left input pins will regulate the rotation of motor connected across left side and right input for motor on the right hand side.
- The motors are rotated on the basis of the inputs provided across the input pins as LOGIC 0 or LOGIC 1. In simple you need to provide Logic 0 or 1 across the input pins for rotating the motor.

- **L293D Logic Table:**

Let's consider a Motor connected on left side output pins (pin 3, 6). For rotating the motor in clockwise direction the input pins has to be provided with Logic 1 and Logic 0.

- Pin 2 = Logic 1 and Pin 7 = Logic 0 | Clockwise Direction
- Pin 2 = Logic 0 and Pin 7 = Logic 1 | Anticlockwise Direction
- Pin 2 = Logic 0 and Pin 7 = Logic 0 | Idle [No rotation] [Hi-Impedance state]
- Pin 2 = Logic 1 and Pin 7 = Logic 1 | Idle [No rotation]

In a very similar way the motor can also be operated across input pin 15, 10 for motor on the right hand side.

Results

- We are able to drive the motors using the cell phone or laptop.
- 5v power supply circuit has been etched on PCB (temporarily used for driving the circuits and motors).
- DTMF Circuit, Atmega16 Development Board and Motor Driver Circuit etched on Printed Circuit Board.
- PCBs, cell phone, motors, power supply, wheels mounted on the Chassis.
- Phone camera is used to view the path, with the help of Skype.

Applications

- Scientific Uses - Example: Space exploration
- Military and Law Enforcement - Example: Support on war field
- Search and Rescue - Example: During natural calamities
- Recreation and Hobby - Example: Robot Wars, Robot races

Future Scope

- Metal Detector Circuit can be added to the robot.
- IR sensors can be attached to avoid obstacles.
- Alarm phone dialer
- Password protected

Challenges

- CM8870 IC burnt due to short-circuiting.
- Gain of the RC Circuit has to be adjusted according to the signal strength.
- Headphone jack had compatibility issues with few cell phones.
- Geared motor required more voltage than 5v for better functioning.

Conclusion

The primary purpose of the mobile phone operated land rover with DTMF decoder is to know the information in the places where we cannot move. The robot perceives the DTMF tone with the help of the phone stacked in the robot. It provides the advantage of robust control, working range as large as coverage area of service provider.

References

- Data sheet of - CM8870, Atmega16, L293D
- <http://www.evelta.com/>
- <http://www.micahcarrick.com/tutorials/avr-microcontroller-tutorial/>
- <http://forum.allaboutcircuits.com/threads/troubleshooting-cm8870-dtmf-decoder-circuit.79443/>
- Shatnawi, A. Abu-El-Haija, A. Elabdalla, “A *Digital Receiver for Dual-Tone Multi-frequency (DTMF) Signals*”, Technology Conference, Ottawa, CA, May 1997.
- M. Felder, J. Mason, B. Evans, “*Efficient Dual-Tone Multi-frequency Detection Using Non-uniform Discrete Fourier Transform*”, IEEE Signal Processing Letters, Vol. 5, No. 7, July 1998.
- “The 8051 Microcontroller and Embedded Systems” By Muhammad Ali Mazidi and Janice Gillispie Mazidi. Pearson Education.
- R.C. Luo, T.M. Chen, and C.C. Yih, “Intelligent autonomous mobile robot control through the Internet,”IEEE International Symposium ISIE 2000, vol. 1, pp. 6-11, December 2000
- Emerging trends in robotics and communication technologies, 2010 International conference on Robotics & control systems.